

Volume 57

Part 4

# QUEENSLAND AGRICULTURAL JOURNAL

Edited by  
J. F. F. REID  
Associate Editor  
C. W. WINDERS, B.Sc.Agr.



---

---

**OCTOBER, 1943**

---

---

Issued by Direction of  
THE HONOURABLE T. L. WILLIAMS  
MINISTER FOR AGRICULTURE AND STOCK

GOVERNMENT PRINTER, BRISBANE



## Contents



	PAGE.		PAGE.
Event and Comment—		The Dairy Industry—	
Primary Production in Queens-		Fodder Conservation .. ..	231
land .. .. .	195	The Methylene Blue Test ..	234
Field Crops—		Production Recording .. ..	236
Saccharine Sorghums .. ..	197	The Pig Farm—	
Navy Bean Production .. ..	202	Feeding Bacon Pigs .. ..	238
Cotton Culture—		Pointers for Pig Farmers ..	241
Breeding Jassid-resistant Cotton		Poultry—	
Varieties .. .. .	204	The Storage of Eggs .. ..	242
Fruit Culture—		Animal Health—	
A Wireway for Bananas .. ..	207	Milk Fever and Pregnancy Sick-	
Strawberries in North Queensland	211	ness of Ewes .. .. .	244
Vegetable Production—		Treat Sheep for Stomach Worm	
New Method of Seed Extraction	213	Now! .. .. .	248
Applied Botany—		Agricultural Chemistry—	
Edible Trees and Shrubs—Broad-		Specimens from Dead Animals ..	250
leaved Sally Wattle .. ..	214	Irrigation Water Analysis ..	251
The Varieties of Tonga or Tongan		Marketing —	
Bean Cultivated in Queensland	215	Pigmeat Plan Revised .. ..	252
Plant Protection—		Gadgets and Wrinkles—	
Insect Pests of Cabbages and		A Gate Without Hinges .. ..	253
Cauliflowers .. .. .	217	Nailing Wallboard .. ..	253
Sheep and Wool—		The Farm Home—	
The Romney Marsh .. ..	226	Care of Mother and Child ..	254
Hints on Sheep Management ..	228	The Makings of a Square Meal	255

**ANNUAL RATES OF SUBSCRIPTION.**—Queensland Farmers, Graziers, Horticulturists, and Schools of Arts, **One Shilling**, members of Agricultural Societies, **Five Shillings**, including postage. General Public, **Ten Shillings**, including postage.



---

---

Volume 57

1 OCTOBER, 1943

Part 4

---

---

## Event and Comment.

### Primary Production in Queensland.

**T**HE general pastoral and agricultural situation is reviewed in the Annual Report of the Department of Agriculture and Stock for the year ended 30th June last. Following is a brief summary of the main points of the Report:—

The statistical position of the pastoral industry as on the 1st January, 1943, is indicated in the following livestock figures:—Sheep, 25,150,000; cattle, 6,400,000; horses, 450,000; and pigs, 315,000.

Although wool and fat sheep values were satisfactory, there was little demand for store sheep. Weekly sale yardings of fat sheep were sufficient to meet requirements and quittances were satisfactory to the producers. There was an increase in fat lamb deliveries, most of which showed evidence of type and quality and correct marketing age, and, therefore, that producers are breeding and fattening on proper lines. Fat lamb raising is now an expanding practice in districts other than the Darling Downs and the production prospects of this important branch of the pastoral industry have improved commensurately. Merino breeders are continuing to improve flock standards. Merino stud establishments also are increasing in number and should have a gradually extending influence on the maintenance of the reputation of the State for the production of high quality Merino wool. The health and condition of flocks are good. The increase in the price of wool has added to the stability of the industry and strengthened confidence in its future. Investigations into animal diseases and diagnostic work were somewhat limited as the result of calls made on the veterinary staff for war duty. Prevention rather than cure has always been the aim, and this is all the more essential because of present national food requirements.

Production of raw sugar for the 1942 season was 605,615 tons. Cane harvested totalled 4,350,487 tons, thus 7.18 tons of cane were required to produce 1 ton of sugar—a value exceeded only once in the last fourteen years. The average price of sugar was £18 13s. 11d. per ton, compared with £17 18s. 4d. for the previous season's output, and the value of the crop was, therefore, approximately £11½ million.

Cotton acreage was reduced because of adverse climatic conditions at the normal planting period. The importance of increased cotton production and cotton seed oil and meal has induced farmers with suitable conditions to include cotton-growing in their cropping plans.

Wheat grain prospects were very promising early in the season, but the dry period which followed retarded crop development. Because of further set-backs from rust infestation and hail and frost damage, the yield for the year did not exceed 4½ million bushels. Maize crops yielded well and the grain generally was of high quality. The cultivation of grain sorghums is expanding rapidly, especially in districts where the occurrence of rain at the right time for maize is uncertain.

High yields of summer grain and root crops were obtained. To meet a rapidly increasing demand greater attention has been given to the production of potatoes and other vegetable crops, particularly in the Northern districts. An interesting development was the successful winter production of potatoes in the Ayr and Mackay divisions, which relieved heavily-taxed transport from the South.

Summer sorghum crop reservations provided good grazing of particular value in supplementing the pastures for both sheep and cattle. Other summer fodder crops, including lucerne, were in abundance, but because of the general shortage of farm labour, conservation was not practised as extensively as in former years. Tobacco production was below the average of recent years, chiefly because of lack of labour for planting and harvesting.

Every effort was made to supply an extraordinarily increased demand for fruit and vegetables. The production of vegetables as near as practicable to centres of consumption has resulted in large scale production in North Queensland, both on the coast and tablelands. In other parts of the State vegetable production also has greatly increased. The output of the Granite Belt region is particularly important, since the crops mature in mid-summer, when production from coastal farms is limited. Plans are being made for a further increase in acreage for the coming season. Pineapple and citrus growers also are contributing greatly to the national war effort by increased production and extension of processing facilities.

Dairy production for the year was the highest for any year since the war began, notwithstanding the fact that a large quantity of milk had been diverted to fulfil Army contracts. Increases in the retail prices of butter and cheese, together with a Commonwealth subsidy, have led to the economic stabilisation of the dairy industry. Cheese production has expanded in a period of two years to about two and a-half times the pre-war output, constituting a record for Queensland, now the highest cheese-producing State in the Commonwealth. The war-time contract entered into by Britain with Australia for the purchase of all Australia's exportable surplus dairy produce was renewed.



## Saccharine Sorghums.

C. S. CLYDESDALE, Senior Instructor in Agriculture.

**S**ACCHARINE sorghums are characterised by succulent stems, the juice of which is distinctly sweet and contains an appreciable amount of sugar.

The seed of the saccharine sorghums has frequently a rather bitter flavour, with an astringency which is absent or less noticeable in most of the varieties of the grain group. This, however, does not prevent stock from eating the seed readily.

As fodder, the saccharine sorghums are not only much more nutritive, but usually they provide a greater yield of green fodder than do most of the grain sorghums. The leaves and stalks are very palatable, and are readily eaten by all kinds of stock. Analyses show that the nutritive ratio of the saccharine sorghums is wider than that of green maize. The lower percentage of digestible crude protein in the saccharine sorghums demonstrates maize to be the more valuable stock food, since, to obtain a desirable balance, more fodder or concentrate rich in protein has to be added to the former. The superiority of maize also is supported by the fact that it can be fed at any stage of growth, while saccharine sorghums should not be fed before the flowering stage because of the risk of poisoning when fed at an earlier stage of development.

Saccharine sorghums, however, have the advantage that, on fertile soils, they produce a crop at least as heavy as maize and produce better yields on the poorer soils than maize is capable of doing. They also preserve their succulence to a greater degree and for a longer period than does maize after being frosted. In the form of either fodder or silage, saccharine sorghums are a valuable feed for dairy cows, especially if fed with a legume in either the green feed or the hay stage. Saccharine sorghum silage is also an excellent standby for very dry conditions, not only as feed for working stock, but also for maintaining condition on the other farm animals. The easy digestibility and the moisture content of such silage are particularly valuable under such conditions as preventives of impaction, which is frequent in cattle and sheep when they can get only dried up, coarse, and fibrous grasses.

### Varieties.

In Queensland, a great many varieties of saccharine sorghum have been tried out. Only the following few, however, have been extensively grown.

One of the oldest and, until recently, the most popular variety is Planter's Friend or Imphee. It stools well, has stout stems and large leaves, and grows to a height of from 6 to 10 feet. It is very sweet and succulent. The heads are large, compact, and erect, and the seed is brown. It is valuable either for feeding as green fodder when mature or for silage.

A more recent introduction is Saccaline, which has become the most popular variety within the past 20 years for green fodder and for silage making. It reaches maturity in about the same period from sowing as Planter's Friend. Its stems are medium large, with abundant leafage, and grow from 6 to 10 feet in height. The heads are large, compact, slightly drooping, and carry a large quantity of seed. The seed is reddish in colour, with short dark-red or black glumes.

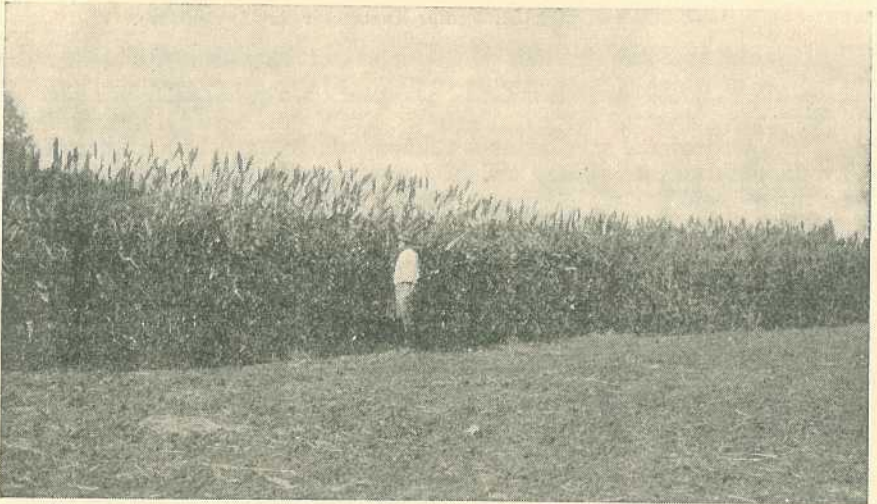

Plate 51.

SUGARDRIP.—A promising new saccharine sorghum.

Seed of the Honey variety was received from the United States Department of Agriculture in 1923 and tested out over a number of years in the Northern and Central Districts of this State. In the far North, it eclipsed all other varieties in yield in comparative trials, and it is now a very popular variety in that part of Queensland. It is a tall-growing variety, sometimes attaining 12 feet in height, and is characterised by the possession of longer stem internodes than other varieties. Honey leaves are large and the heads are loose, open, and erect, with much less seed than is the case in Saccaline. The seed is reddish-brown and is almost completely enclosed by shining dark-red glumes. This variety is commended for its succulence, sweetness, and low fibre content, which is associated with the length of the internodes. It takes from 110 days to 130 days to reach maturity.

Good results have been obtained with other varieties, such as White African, Sugardrip, Orange, Italian, and Sumac. Colman is a promising new saccharine sorghum, and Atlas is a dual purpose variety.

### Mixed Crops or Sorghums and Legumes.

Sorghums for silage may be grown with a summer growing legume, such as a suitable variety of cowpea or velvet bean. However, there are considerable objections to this procedure, and it cannot be recommended as a general practice in Queensland, although on the Atherton Tableland it may be adopted with some measure of success. Experience shows that generally larger yields will be obtained when the crops are grown separately and then mixed when filling the silo. Furthermore, separate crops present less difficulty in harvesting than does a mixed sorghum and legume crop.



Plate 52.

COLMAN.—Another new saccharine sorghum.

Where Sudan grass or other fine-stemmed sorghums are sown for feeding off or for haymaking the inclusion is recommended of early maturing varieties of cowpeas, such as the Black in the southern districts and Groit in the northern Tableland areas. The cowpea should be sown broadcast, using 10 to 15 lb. of the Sudan grass with 4 to 5 lb. of the cowpea per acre.

### Rotations With Sorghums.

Sorghums are sometimes considered to deplete the fertility of soils excessively, as non-leguminous crops following sorghums frequently yield less than normally anticipated. Other theories have suggested that the sorghum roots, during the growth of the plant, secrete a substance that is toxic or slightly poisonous to the following crops, as evidenced by the light, yellowish-green leaves of such crops, especially on soils that normally have a low nitrogen content, or on various types of soils in dry seasons.

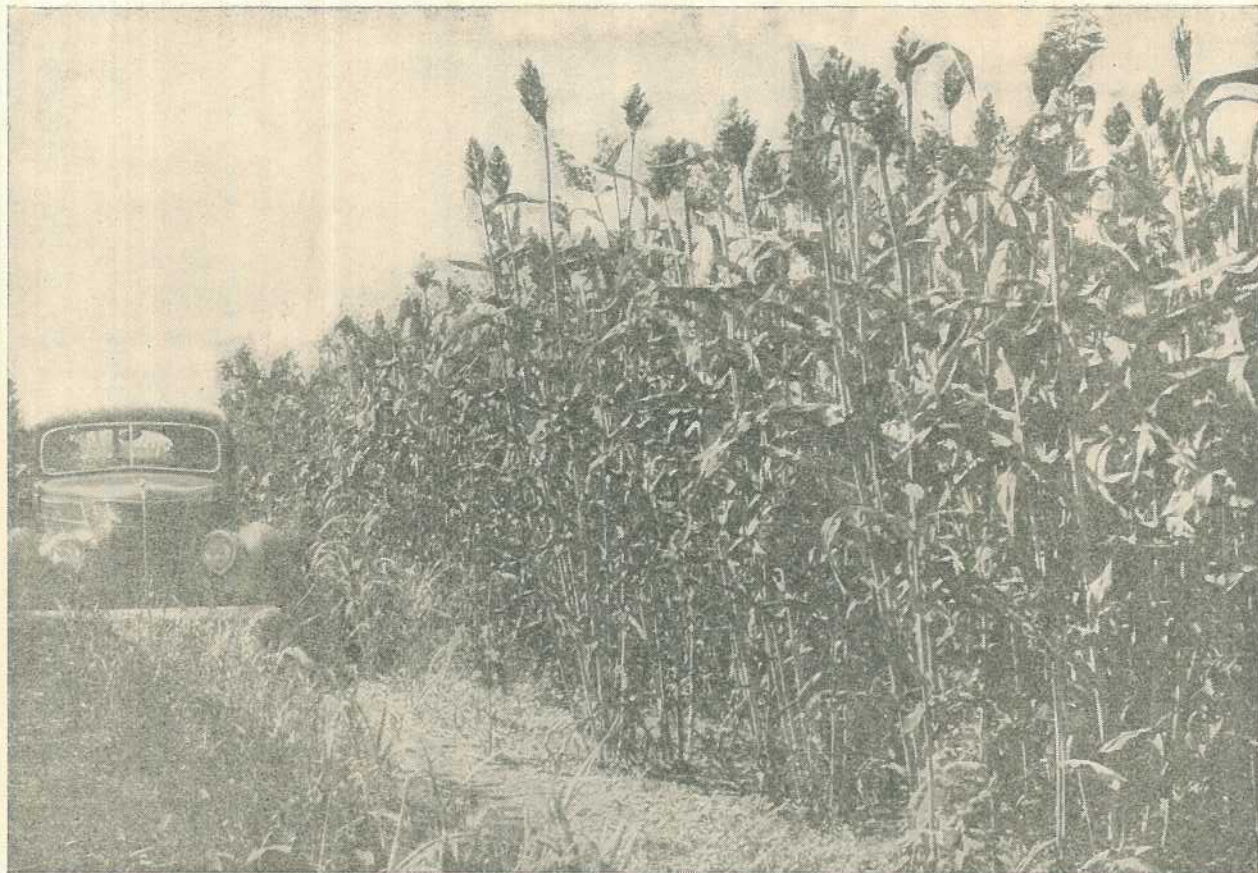

Plate 53.

SACCALINE.—The most popular of the saccharine sorghums.



Investigations in the United States of America indicate that the reductions in the yield of non-leguminous crops following sorghums are mostly due to the depletion of the nitrate nitrogen by the sorghum crop and to the amount of sugars in and near the crown of the sorghum plant. These sugars may be so concentrated that soil micro-organisms attempting to decompose them and the old sorghum roots during the period when the following crop is growing compete with that crop for the nitrates present, thus further reducing the supply of nitrates available for the crop following the sorghum.

Sorghums should, therefore, be grown in rotations in which either an inoculated legume is grown after the sorghum crop, or in which the land is ploughed as soon as the sorghum is harvested, or grazed off and is then left as a moist, bare fallow until the roots are properly decomposed before some other non-leguminous crop is sown. Both procedures should provide ample amounts of nitrogen for following non-leguminous crops, if the nitrogen content of the soil were satisfactory before the growing of the sorghum crop. Generally speaking, unless the soil is very fertile, it is advisable to follow a sorghum crop with a legume, after which any crop, other than cotton, may be grown before again growing sorghum.

#### Poisonous Properties Of Sorghums.

All of the sorghum varieties can possess more or less poisonous properties up to the flowering stage, because of the presence of a prussic-acid-yielding glucoside. Young growth, stunted growth, or growth that has been frosted before flowering is regarded as particularly dangerous. Wild sorghum is dangerous throughout its whole life. Sudan grass, when pure, is often grazed at all stages of growth without ill-effect, yet there are instances of serious losses having occurred thereby. Great care should be exercised in feeding or depasturing any variety of sorghum before the flowering stage has been reached. The degree of danger depends, however, largely upon the rate of growth, the plant being most harmful when growth has been interrupted or delayed by unfavourable conditions.

#### SUGAR CANE AND ITS CULTURE.

Volume IV.—Sugar Cane and Its Culture—of the Queensland Agricultural Handbook Series is now out of print. Consequently, no further copies are now available.

• • •

Volume I.—Farm Crops and Pastures (5s., post free); Volume II.—Horticulture (4s., post free); and Volume III.—Insect Pests and Plant Diseases (3s., post free) of the Handbook Series are still available and are obtainable at the prices stated on application to the Under Secretary, Department of Agriculture and Stock, William Street, Brisbane.

## Navy Bean Production.

J. A. KERR, Instructor in Agriculture.

**S**UBJECT to the availability of equipment for mechanical harvesting, including modern threshing machines, and also to the provision of centrally-situated grading facilities, the production of navy beans for canning should become an important enterprise in the South Burnett.

Among the reasons why this crop should establish itself in favour are:—

1. The short season from planting to harvest (approximately 3 to 3½ months).
2. Average net returns with favourable weather, which should be from £10 to £15 to the acre, with higher returns probable.
3. Cropping sequence—January will probably be the most favourable planting month, permitting the previous establishment and first cultivation of normal maize and peanut crops.
4. The beans do not shatter freely nor readily weather stain, unless prolonged wet weather is experienced.

### Soils.

Experience during the past few years indicates that the principal qualification of suitable soils is reasonably good fertility. High yields have been obtained on soils varying from sandy loams to chocolate soils, including a large range of red loams, but planting on poor soils is not recommended.

### Soil Preparation.

Soil preparation should be in accordance with normal cultural methods designed to conserve moisture and produce a medium fine seed-bed.

### Planting.

Late December to the end of January is the most suitable planting period. January planting should permit crop maturity during April, when harvesting weather should be generally favourable. Moreover, January planting should fit in with other farm crop operations.

The application of superphosphate should generally be beneficial. Planting is usually done with a maize planter with a row spacing of from 2 feet 8 inches to 3 feet. When peanuts are grown on the same farm, a similar row spacing is used to facilitate row cultivation. Approximately 12 lb. of seed of navy beans to the acre are required, with average plant spacings of from 4 to 6 inches in the row. Because of the late planting, rarely more than two and frequently only one row cultivation will be necessary.

### Harvesting.

Harvesting may be delayed until most of the pods are almost dry. Shattering has not been of any serious consequence in the South Burnett during the past three seasons.

The use of the bean cutter which cuts two rows at a time and diverts them to one central windrow will probably be the usual method of harvesting during the next season, although the pea attachments to the header-harvester may prove useful for the work. Where the header-harvester is not to be used on the windrows, the beans are usually placed in small cocks to complete drying. They may be then threshed in the field or conveyed to haysheds awaiting the arrival of suitable threshing machines. Threshing machines designed to handle wheat or cowpeas are suitable. Peanut drum threshers will thresh the beans. Further grading may be necessary to produce top grades.



Plate 54.  
A two-row bean cutter.

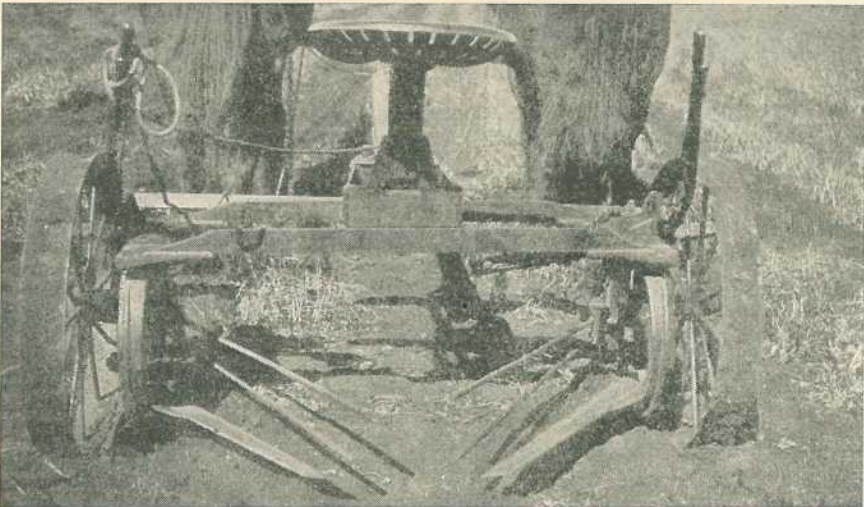

Plate 55.  
A close-up view of a two-row bean cutter, showing cutting blades and guide rods for placing bean plants into a single windrow.



## Breeding Jassid-resistant Cotton Varieties.

S. MARRIOTT, Assistant Research Officer.

**I**N the article on cotton breeding, which was published in the September number of this journal, mention was made of the programme of work which is being conducted in this State in order to develop jassid-resistant varieties. Herein follows a description of this work, which not only shows what improvements have been made, but also serves to illustrate with actual examples how the three main systems of breeding described in the previous article, namely, mass selection, individual plant selection and hybridisation, have been used in this problem.

In this, as in most similar projects, it must be understood that all three methods may be employed simultaneously. It is to be expected that, if a variety contains individuals with the desired characters, mass selection of these types will result in a rapid improvement of the variety up to a certain point beyond which, however, further progress is slow. Individual plant selection of superior types in the variety will lead more slowly to a still further degree of improvement in it, while hybridisation may result in the production of a strain comparatively close to the plant-breeder's ideal, which, in this case, is a strain of cotton with desirable plant and fibre characters together with an extremely high degree of jassid resistance, if not immunity.

It was found in Africa and India, where jassids are also serious pests of cotton, that whenever really resistant plants were found, they always exhibited the character of leaf hairiness. Unfortunately, however, not all hairy plants are resistant, because if this were true, the isolation of resistant strains would be simple. The problem is further complicated by the fact that, under some conditions of soil and soil-moisture, plants which may be either hairy or quite hairless also appear unaffected by jassid, and it is only by growing their progeny under conditions of heavy jassid incidence that their resistance or susceptibility may be demonstrated.

The symptoms shown by a susceptible plant during a jassid attack may be described briefly as first a curling down of the leaf margins, followed by a discolouration of the leaf margins from green to yellowish-green, then to bronze-green, and finally to a red colour. On examination of the under surface of the young curled leaves, the small pale yellowish-green jassids may be observed. They move in a characteristic sideways fashion. A badly-affected plant may cease all growth and flower so early in its development as to result in a poor yield being obtained.

It was possible to use selection methods in the problem of developing jassid-resistant cotton in Queensland since it had been observed that, in some varieties, and in Miller in particular, occasional resistant plants occurred in jassid-infested fields. Initial studies of these plants and their progenies revealed that in some cases the resistance was inherited and this preliminary work developed into the actual individual plant selection phase of the problem. As certain strains showed remarkable uniformity for resistance in their first generation as separate progenies, it was unnecessary to adopt mass selection methods, until a heavy attack of the spur-throated locust destroyed a large seed increase plot of the most resistant strain, leaving only a small residue of seed. This loss made necessary the use of the more rapid but less efficient method of selection already mentioned under the name of mass selection.

### Mass Selection.

As the chief character desired in the new strain was jassid resistance, a field of Miller 41 cotton heavily infested with jassids was inspected, and the seed from all apparently resistant plants with the exception of those showing major deficiencies in other characters, such as very small bolls or very short lint, was bulked. This mass selection yielded sufficient seed to plant five acres in jassid country, where unfortunately only a mild attack was experienced, making re-selection impracticable. As a whole, however, the plot was uniformly, hairy, and seemed to be showing less leaf curl than the nearest crop of commercial Miller grown on similar soil. The seed from the plot was therefore bulked, and in the following season, i.e., 1942-1943, about 100 acres of the strain were grown, and good yields of satisfactory fibre were obtained. Studies of the plant population showed that the strain was distinguishable from commercial Miller by virtue of increased plant hairiness—a significant sign. This strain, which is known as 41J, is most heterogeneous, however, as is to be expected from its origin, and is not considered to show any more than a 20 per cent. increase in jassid resistance. A fresh mass re-selection which has been made should yield an improvement in resistance. Losses from jassid may be so severe in some districts, however, that the bulk stock of 41J seed produced in 1942-43 will be released for commercial planting, as the strain may reduce, to some extent, the losses sustained through jassid attack.

### Individual Plant Selection.

Individual plant selection was commenced in the 1938-39 season, and the Miller strain 111-26, originating from a single plant selection, has been remarkably jassid-resistant, while in addition it has exhibited marked uniformity in all seasons for plant and lint characters. This uniformity decreases the chances of obtaining further superior types from it, but also guards against deterioration through segregation into undesirable types during the period of multiplication of the seed to commercial proportions. In strain trials, as well as in multiplication plots, it has shown great freedom from jassid injury and good yielding ability. During last season the strain produced seed cotton which was graded into a 15/16-1 inch staple length, while the fibre strength and body were classed as very good. The fibre is coarse, and this may indicate its ability to produce a strong lint even under adverse climatic conditions. About 10 acres of this strain will be planted in the coming season, and in addition numerous re-selections will also be grown. This

strain, however, bears only a medium-sized boll, and also produces a rather leafy type of plant. Since, as mentioned above, the high degree of uniformity makes it improbable that these defects can be corrected by selection, the search for other pure strains is continuing. Of all the primary selections made from Miller and grown in plant to row plots in the search for these improved resistance strains, about 25 per cent. have survived in the form of re-selections, and some of these families appear promising as their plant habit and ginning percentages seem to be improvements on the two main resistant strains so far isolated.

### Hybridisation.

The hybridisation method was also incorporated in the breeding programme because it was found that all imported jassid-resistant cottons have been useless from a commercial point of view, although they often possessed a very high degree of resistance. This has amounted to practical immunity in the case of the most recent introduction, which is the Ferguson variety kindly made available by the geneticist of the Empire Cotton Growing Corporation's Cotton Research Station in Trinidad. This project was planned as a relatively long term one, and as the objective was the transfer of the main character of resistance to Queensland commercial cottons, the back-cross method was adopted. This method involves making the initial cross between the selected commercial variety and the resistant introduction, while each subsequent hybrid generation is crossed back to the commercial type, care being taken to ensure that only those hybrids which exhibit resistance are used as parents. If the back-crossing is continued for a sufficient number of generations, the resultant hybrid will be practically identical with the recurrent parent, with the addition of the character transferred to it from the other parent—in this case resistance. By subsequent individual selection of resistant plants satisfactory strains, combining resistance and suitable plant and fibre characters, are eventually evolved.

The variety chosen as the recurrent parent was Miller, it being the most extensively grown variety producing good quality lint and adapted to a wide range of conditions. The resistant parent used was the South African variety U4 or a U4 derivative. The Ferguson strain already mentioned may supplant the U4 strains in this work. It has been found that the first generation hybrid seems intermediate between both parents for such characters as boll size and ginning percentage, while its jassid resistance is as high as that of the resistant parent. On the other hand, the first back-cross generation—*i.e.* (Miller x U4) x Miller—approaches quite close to the Miller type of large boll and strong fibre, while selected plants also retain a high degree of jassid resistance. Three such strains, after some years of simple plant selection, show sufficient uniformity in quality, resistance, and yielding ability to warrant their being increased for adequate testing. Third back-crosses—*i.e.* {[ (Miller x U4) x Mi ] x Mi; x Mi—and fourth back-crosses which have been made should be even more valuable and less variable, but their establishment on a commercial scale will require some years of work.

From the above outline of the progress made in this project it should be evident that it has been sufficiently satisfactory, in developing promising jassid-resistant strains of the Miller type of cotton, to warrant its expansion to include some other varieties. Accordingly, the New Mexico Acala and Triumph varieties have been crossed with the Ferguson variety as the first step in evolving jassid-resistant strains of these two important cottons.



## A Wireway for Bananas.

H. BARNES, Director of Fruit Culture.

**A**N endless wire system on the flying-fox principle for conveying banana bunches from the plantation to the packing-shed will save time and much hard work. Such a system also would be useful on any hillside orchard.

Briefly, the idea of the system is to despatch fruit by gravitation from a central point in a plantation to the packing-shed. The system is of simple construction, as shown in the illustrations. With round-grooved wheels, the carriers run on an endless wire, so that as one is despatched to the packing-shed with a load its weight pulls the other up to the point of despatch for another load. Installation of the system is not difficult, but its efficiency in operation must obviously be based on its structural strength. On very steep grades a simple breaking system will regulate the speed of the loaded carrier.

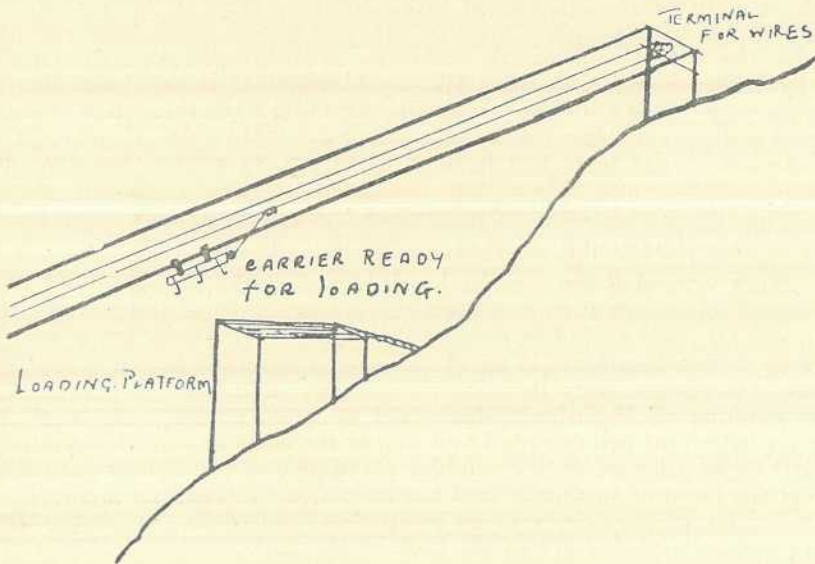

Plate 56.

AN ENDLESS WIREWAY FOR CONVEYING BANANA BUNCHES FROM THE PLANTATION TO THE PACKING SHED.

A central site on the plantation should be chosen as a convenient despatching point and, of course, a lower site at the packing-shed as a receiving station. A suitable place for the loading platform would be on the top of a rise, so that the wireway would be high enough for the banana bunches on the carrier to clear the banana plants when in transit. The site of the receiving terminal should, of course, be suitable also for the building of a packing-shed with easy access to a roadway. On some slopes there may be some difficulty in obtaining sufficient height for the wireway, but this may be overcome by building stagings at both the despatching and receiving points, as illustrated (Plate 56).

### Construction of the System.

Details of construction are shown in Plate 57. The main posts marked A at both top and bottom terminals must be solid and about 12 feet long. They should be firmly fixed in the ground, at least 4 feet deep and preferably 5 feet, and should be well braced. In the sketch the posts at the despatching end are shown anchored to a convenient stump for additional strength. The distance between the posts at each terminal may be about 6 or 8 feet.

About 6 inches from the top, bore inch-diameter holes through each of the posts for the carrier wires (B). The holes in the posts at the top end should be inclined downhill and those through the bottom posts inclined uphill, so that the wires when strained will not kink at the entrance to the holes. A straight pull also makes it easier to strain the wires, which should be drawn as tightly as possible. To do this, tie the wires firmly round the posts at the sending end, and at the receiving terminal wind the slack of the wires round good strong rollers (C). If wooden rollers are used, they should be made of tough cross-grained timber, 4 inches in diameter, clear of sap. Straight-grained timber is liable to split and is not capable of carrying the load. Iron levers,  $\frac{3}{4}$  inch to 1 inch diameter (D), passed through holes bored at right angles to one another in the ends of the rollers will give a good purchase and enable the wires to be tightly strained. For the carrier wires, heavy 10 by 12 gauge oval steel wire (if now obtainable) is sold specially for the purpose. This wire has a breaking strain of 2,140 lb., and is suitable for all ordinary distances up to approximately 600 yards. Some systems in use are a mile long, but heavier wires are, of course, required for them.

For the endless wire (K), 12 by 14 gauge steel wire is generally used. This runs round grooved wheels fixed at each terminal.

Posts marked E are sunk and well braced at the receiving terminal. If a good anchorage such as a stump is not available at the despatching end, similar posts should be erected there also. Cross bearers (F) made of 4 by 3 inch hardwood to carry the wheels are then bolted across the posts. Care is necessary in fixing the bearers, as in order to prevent the wire running off the wheels they must be tilted slightly, the wheel at the top being inclined downhill and that at the bottom uphill. In Plate 57 it will be noted that at the sending terminal the top bearer is placed across the front of the posts, and the posts are checked out to allow the bottom edge of the bearer to be completely housed in the posts. The lower bearer is placed across the back of the posts, and in this case the posts are checked out so that the top edge of the bearer is completely housed. A piece of solid hardwood is next bolted to the top of the bottom bearer to form a small platform (G), so that when a hole for the axle of the wheel is bored through the top bearer the auger will



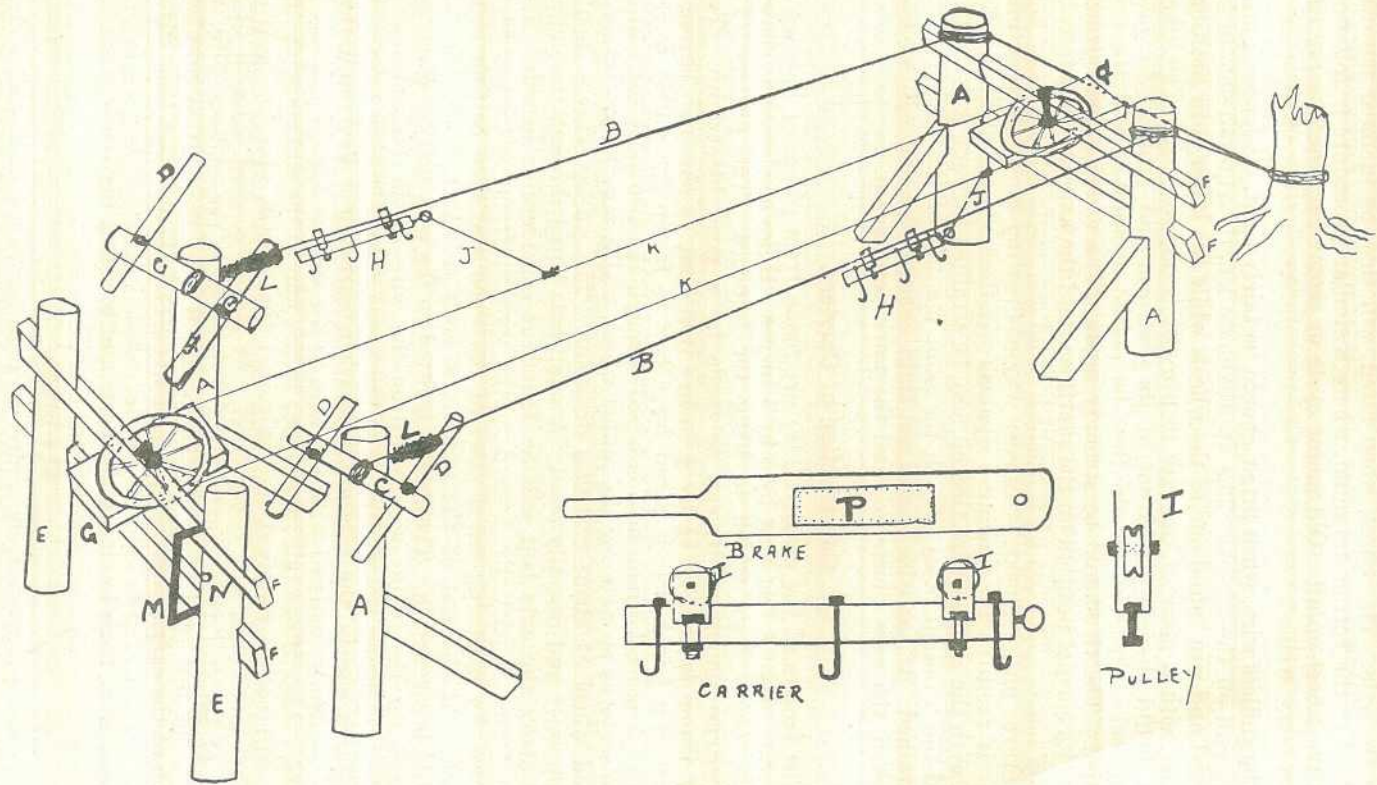

Plate 57.  
 SKETCH SHOWING DETAILS OF WIREWAY CONSTRUCTION.

continue on and bore a corresponding hole in the platform for the other end of the axle. The wheel, when fitted, will then be inclined towards the wheel at the bottom terminal, where a similar procedure is followed to tilt the wheel uphill. Old motor cycle or motor car wheels serve the purpose very well.

The endless wire, when fitted, should be fairly tight, otherwise it will tend to run off the wheels. The approximate length required should be measured and run round one of the wheels while the latter is in position, and tied with a piece of tie wire to prevent it slipping off. The other wheel should then be lifted out of its platform and brought forward several feet. The wire should then be placed around it, and the two ends tied. The tie should be strongly made. The wheel is next drawn back to its correct position on the platform, and the axle inserted to hold it in its place. The use of a Spanish windlass, made with a rope and two or three pulley blocks, is an easy way of drawing the wheel back into place. If facilities for making a Spanish windlass are not available, the wheel with the endless wire tied on may be strained through a post fixed behind the terminal posts (E) in the same manner as the carrier wires are strained. If the wire is still not tight enough, the join will have to be broken, the wire shortened, and the work done again.

#### Construction of Carriers.

The frames of the carriers (H) are made from pieces of hardwood measuring about 4 feet long by 3 by 1 inches. Holes are bored as shown for the hooks from which to hang the bunches. The pulleys (I), if otherwise unobtainable, can be made by a good blacksmith. The pulley frame is usually  $1\frac{1}{2}$  by  $\frac{1}{4}$  inches iron bent as shown. Through the bottom a  $\frac{3}{8}$ -inch hole is bored for a bolt to fasten the pulley to the carrier. A second  $\frac{3}{8}$ -inch hole is bored through the two sides for a steel bolt to serve as an axle for the pulley wheel, which may be an ordinary grooved wheel of about 2 inches diameter. The pulley wheels should be frequently and liberally oiled. A small hole bored through the pulley wheel above the axle bolt will be found of considerable benefit. The pulley frame is partially housed in the wooden frame of the carrier, as shown, by mortising out a piece of the wood and then bolting right through. At the end of the carrier, a hook to which to tie the tail rope (J) is screwed in. The carrier is fitted on the wire (B) by removing the axles for the pulley wheels, fitting the wire in the pulley frames, and then replacing the wheels. The tail ropes should be long enough to allow for a sag in the carrier wires when carrying a load, and they should be firmly fastened with the wire to the endless wire to prevent it slipping. Also, if one tail rope is tied to the join in the endless wire, the latter will not be required to run round the wheels, and the tie will therefore not cause any obstruction. It also is a good idea to fit a swivel in the tail rope, near where it is tied to the endless wire, to prevent the tail rope from twisting round it. At the bottom terminal of each of the carrier wires, a piece of wood (L) about 2 feet long wired on will act as a stop to hold the carrier when it arrives with its bunches, and prevent it from bumping the posts and bruising the fruit.

#### The Brake.

The brake is made from a piece of solid hardwood fashioned with a handle like an elongated cricket bat. It should be loosely fastened with a long bolt to one of the bottom posts at the point "N." For extra strength a piece of iron (M) may be bolted through the post to form a

D, through which the brake is inserted. The brake should be only loosely bolted, as it must be capable of being moved forwards and backwards, according as it is pressed against the wheel to check its speed or released to allow the wheel to spin faster. A piece of leather (P) tacked to the face of the brake where it comes into contact with the wheel will increase its efficiency.

---

## Strawberries in North Queensland.

W. G. HANCOCK, Fruit Branch.

**T**HE strawberry is a plant of the temperate zones. While with suitable treatment it may make good growth, and flower and fruit during the cooler autumn, winter and spring months in North Queensland, the summer there is too hot for it, and plants in the field deteriorate after fruiting and usually die out or produce weak spindly runners. The main reason is the extremely high surface temperature of the soil, which to a low growing and shallow rooted plant is particularly detrimental. Therefore, local runners for planting in autumn are usually weak and poor, while stock brought from the South has the disadvantage that its origin is unknown.

### Plant Selection.

Strawberries show wide differences between plants of a variety, in respect of quantity, quality, size and type of berry and other points. This may be seen in most plantings from runners selected haphazardly. Since vegetatively reproduced plants follow closely the characteristics of the parent, whether good or bad, it is quite important to be very critical in selecting only desirable strains. This, of course, applies everywhere, but the method of growing for the tropics about to be described shows the necessity of it in a very practical way.

### Soil.

This method is to plant on ridges, reasonably wide and flat at the top, centred 2 feet 6 inches apart, and the plants set 16 inches to 18 inches in the rows. Very early in March is the usual time. The most suitable soil is a good light loam, which should be carefully prepared and well manured. If possible, animal manure should be used together with some superphosphate, otherwise a complete fertiliser; but strawberries do best when ample humus is present in the soil.

### Irrigation.

Irrigation is essential, and water should not be stinted. The water may be run into the furrows so that the plants are not actually wetted, but so that the soil around the roots will have ample moisture. When it is necessary to work amongst the plants—for example, when picking—each alternate furrow may be filled turn about, so that there is always a dry furrow to walk along. If it is necessary to apply fertiliser during growth; a water-soluble mixture may be thrown in small quantities into the water. If the ground is clean and has been well prepared, weeds should not cause trouble during the comparatively short period of growth and cropping.

### Planting Points.

While the crop is on and the plants can be judged for their productivity, all which are outstanding for the quality and quantity of their fruit can be marked with a small peg, and these, or at least a sufficient number of them, may finally be kept for production of runners. Cropping finished, these plants are lifted and set out on the level in a well-prepared and manured nursery bed in a cool situation. The remainder of the patch can then be destroyed. The nursery bed should not be heavily shaded, but should have a southern aspect and be lightly shaded from noon onwards. Thus the plants will be spared the afternoon sun. Under these conditions at least eight runners can be counted on each plant, so that the number of selected parent plants need not be more than about one-eighth of the total area intended to plant next season. The bed, therefore, can be kept small and manageable, permitting frequent watering and weeding as required, since it is essential to keep the runners growing well. The result will be fine sturdy plants for setting out in the autumn, probably already with several crowns.

This method has been practised at Townsville for many years, and the results have been extraordinarily good. These results are considered to be due partly to the annual selection for fruit quality, and partly to maintaining vigour by holding and propagating the planting material in a cool well-tended nursery bed during the hot summer. The method of planting on ridges and watering by furrows seems to have outstanding advantages for North Queensland.

### Pests and Diseases.

A few pests and diseases are almost certain to occur, and these should be attended to both in the nursery bed and after planting out. Mites cause a withering of the foliage and are controlled by dusting with sulphur. Aphids and thrips should be sprayed with nicotine sulphate and soap. To keep leaf spots under control, spraying with Bordeaux mixture both in the nursery bed and in the field up to flowering time is advisable. A watch should be kept for the virus disease Yellow Edge, and any plants affected immediately destroyed.

### Picking.

As a final hint, it may be remarked that there is a lot of hand work with strawberries, and while they are not hard to grow they require a lot of attention; conversely, they soon exhibit the effects of any neglect. It is wise, therefore, to restrict the area to what may be readily handled. Even from a small heavy-bearing plot a useful return may be taken, as strawberries almost always command a ready sale locally. Picking should be done preferably in the morning as soon as the dew is off, when the fruit can be picked straight into trays or punnets.

#### CHANGES OF ADDRESS.

Subscribers are asked to kindly notify changes of address to this Department without delay.

# Vegetable Production

## NEW METHOD OF SEED EXTRACTION.

*The following information has been supplied by the Commonwealth Council for Scientific and Industrial Research:—*

In Australia and the United States of America, the usual method of tomato and cucumber seed extraction involves the fermentation of pulped well-ripened fruit for 24-48 hours in order to free the seed from the pulp. This process is time-consuming, and is not always entirely satisfactory.

An officer of the Division of Plant Industry, C.S.I.R., has discovered a simple and inexpensive new method which overcomes many of the disadvantages inherent in the old method of seed separation by fermentation. The principle of the new method is to add commercial hydrochloric acid (muriatic acid) to the pulped fruit after which the seed is washed out in the usual way. Tomatoes should be pulped in a wooden barrel or galvanised iron container painted inside with quick-drying bituminous paint, as the acid attacks galvanised iron. Cucumbers are mechanically crushed before placing in the container or are cut lengthwise and the seed-containing flesh scraped into the container, the skins being discarded. The pulp should be well stirred while the acid is acting. If any difficulty is experienced in incorporating the acid into the mixture, the acid can be diluted with about twice its volume of water before mixing with the pulp. After one hour the seed can be washed out in the usual way.

With tomatoes the acid is added at the rate of  $1\frac{1}{4}$  gallons per ton of fruit, which is equivalent to 62 ccs. or one-tenth pint per box of 25 lb. of fruit.

With cucumbers, where the whole fruit is crushed for seed extraction, the same quantity of acid used with tomatoes is satisfactory. Where the seed-containing pulp only is used,  $2\frac{1}{2}$  gallons acid per ton of pulp which is equivalent to 125 ccs. or one-fifth pint per 25 lb. of pulp is needed. The cost of acid per ton of pulp is in the vicinity of 4s. with tomatoes and 8s. with cucumbers, buying acid in 3-gallon jars.

Apart from the considerable saving in time, the new method has the advantage of producing a brighter, cleaner seed sample, which is free from all traces of pulp. Germination is not adversely affected in any way, but is rather improved because of the absence of traces of flesh which carry mould spores and other organisms which interfere with germination, and which can cause disease in the plant. Fruit at all stages of ripeness can be treated with equal success, so that fruit can be picked and processed as soon as it is ripe. Seed yields tend to be higher with the new method, as a better extraction is obtained. It is possible to treat tomatoes or cucumbers and have the seed dried and bagged the same day.

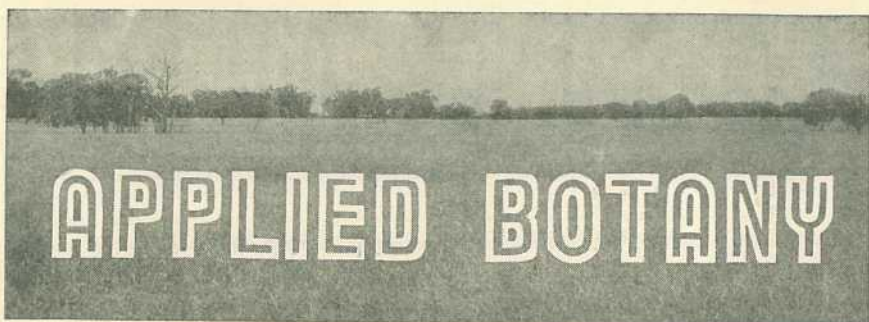

## Edible Trees and Shrubs.

### 2. BROAD-LEAVED SALLY WATTLE.\*

W. D. FRANCIS, Botanist.

**T**HE wattles are leguminous trees or shrubs which are widely dispersed in the warmer parts of the world. The different kinds are most strongly developed numerically in Australia and Africa.

The Broad-leaved Sally Wattle is a common tree in Eucalypt forests and in cleared scrub or rain forest. The trees growing in cleared scrub or rain forest appear to originate from seed carried from the neighbouring Eucalypt forests.

The trees as most commonly met with are bushy types from 15 to 20 feet in height. The bark is generally brown in colour and deeply wrinkled or fissured. The leaves are situated alternately to each other on the branchlets; they are often sickle-shaped in outline, taper at each end, are finely veined lengthwise, and measure from 3-6 inches in length. The flowers are in globular heads and are pale yellow in colour. The pods when ripe are strongly coiled.

The species is widely spread from Atherton and Herberton in the north to Stanthorpe in the south. It penetrates inland in the south to Wandoan, which is about 180 miles from the coast. It occurs also in New South Wales and Victoria.

The leaves and green twigs are readily eaten by stock in dry periods. For this purpose the trees have been lopped or cut down. Destruction of trees is not usually recommended, but in this instance the trees are mostly short-lived. The stems are attacked by boring insects, which eventually kill the trees. Many coastal species of wattle, which form regrowths in felled areas, are subject to the attacks of borers in this way.

\* *Acacia implexa*.

#### NOTICE TO READERS.

Because of the present necessity for strict economy in the use of paper, readers are requested to renew their subscriptions promptly. If renewals are unduly delayed, it may be impossible to supply back numbers of the Journal.

Address all renewals and other correspondence to the Under Secretary, Department of Agriculture and Stock, Brisbane.

## The Varieties of Tonga or Tongan Bean Cultivated in Queensland.

C. T. WHITE, Government Botanist.

ONE of the most popular home vegetables grown in Queensland gardens is the Tonga Bean, a native of India, where it is supposed to have been under cultivation for the past 3,000 years, but now widely found in practically all tropical and sub-tropical countries. Numerous varieties have been described, differing in the colour of flowers and seeds, the former from white to dark purple, the latter from white to almost black.

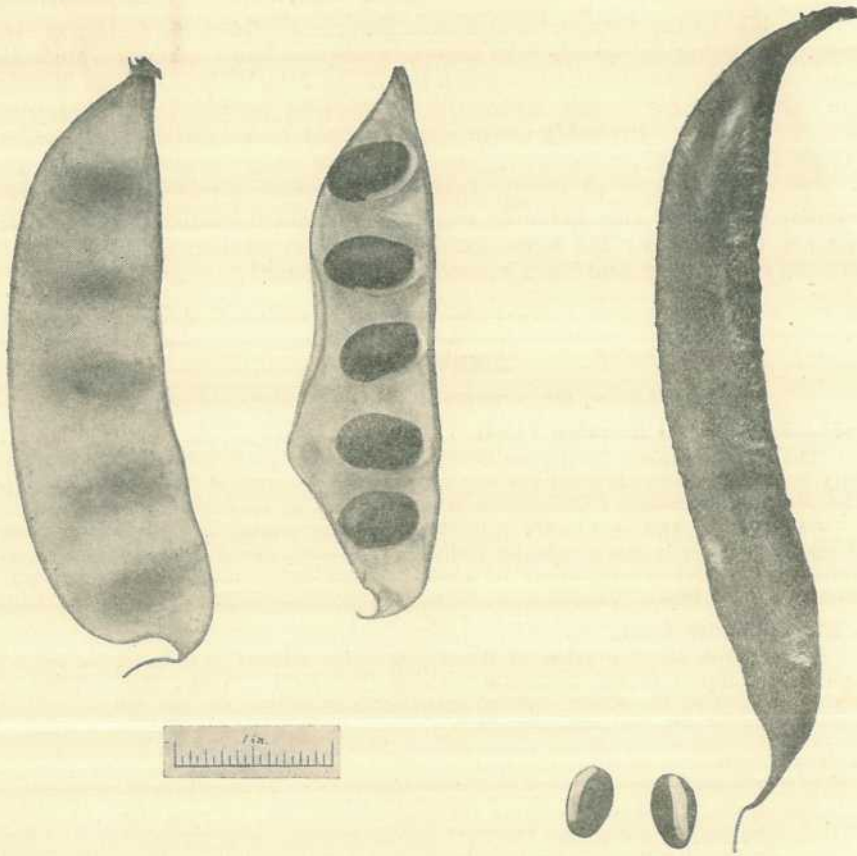

Plate 58.

TONGA BEAN.

Right: PURPLE TONGA BEAN (with two detached seeds).

Left: COMMON TONGA BEAN.

In Queensland we have two main varieties in cultivation, the Common Tonga<sup>1</sup> and the Purple Tonga<sup>2</sup>. The former has violet or pale purple flowers and light green pods, the latter very dark purple flowers and pods of a very dark green suffused on the rather crinkled edges

<sup>1</sup> *Dolichos lablab*.

<sup>2</sup> *Dolichos lablab* var. *purpureus*.

with purple. Both are probably equally good as a vegetable, especially the young pods, which, to get the full flavour, should not be over-cooked, 7-15 minutes in boiling water being ample. The young pods are chiefly eaten here sliced in the same way as French beans, but the nearly-ripe seeds can also be cooked, though the outer skin or covering is rather tough. In Malaya and the East Indies the ripe seeds are cooked and eaten either lightly cooked or raw as labab, that is, a side dish with rice.

Attention is drawn to these beans, as numerous specimens, especially of the purple variety, which is a common ornamental vine in Queensland gardens, have been submitted to know if they are edible or not.

Lablab Bean, Sem or Sim Bean, Hyacinth Bean and Bonavista Bean are names by which it is known abroad. The Common Tonga is also frequently known in Queensland as Poor Man's Bean. It is doubtful how the name Tonga Bean, the commonest vernacular in Queensland, originated. Probably seeds were brought here originally from the Tonga Islands.

The Department of Public Instruction has done good work in distributing seeds of this valuable vegetable to school gardens. The bean is more suitable for the home garden than for market purposes, as it withers on keeping and loses a good deal of flavour.

---

## ANSWERS.

*Selected from the Government Botanist's outward mail.*

### Fodder Plants of the Geranium Family.

The Wild Geranium (*Geranium dissectum*) is a very good fodder plant, particularly for sheep, which are fond not only of the tops but also of the carrot-like root. The plant is sometimes called native carrot because of its root.

The Crane's Bill or Stork's Bill (*Erodium cicutarium*) is sometimes a weed of cultivation, but is also a valuable fodder. It is more abundant in southern Australia than in Queensland, where its place is taken by an allied species generally known as crowsfoot.

### A Winter-growing Grass.

The English Meadow grass, or Goose grass (*Poa annua*) is a European native, now widely spread in the temperate parts of the world. It is fairly common in Queensland during the winter months, particularly in lawns. It does not do well in pastures, preferring sheltered situations.

### Molasses Grass.

R.P. (Palmwoods)—

The specimen is Molasses Grass (*Melinis minutiflora*), in some parts of North Queensland one of the principal fodder grasses. Experience with it in the more southern parts of the State is that stock have to acquire a taste for it before they will eat it to any extent.

### Red Cotton.

A.G. (Springsure)—

The specimen is the Red Cotton (*Asclepias curassavica*), a native of the West Indies and tropical America, now widely spread as a weed in most tropical countries, including Australia. It is a fairly common weed on many coastal farms, along creeks, and in vacant town allotments. Feeding tests have shown that the plant is poisonous to stock. On the other hand, 1½ lb. had no effect on a two-years-old bovine; 3 lb. eaten during two days was harmful to a cow but did not cause death; 7 lb. fed during eight days did not affect a cow. Under normal conditions, stock avoid the plant and the only trouble that has come under notice has been where calves have nibbled at the weed. Usually, they would eat far less than used in the feeding tests.



# PLANT PROTECTION

## Insect Pests of Cabbages and Cauliflowers.

J. HAROLD SMITH, Senior Research Officer.

**C**ABBAGES and cauliflowers are grown extensively in coastal Queensland during the autumn, winter, and spring months, and in upland districts, such as Stanthorpe, during the warmer months of the year. They are attacked by several insect pests, and few crops of these and related vegetables are grown without the application of insecticides in order to keep the pest population down to levels at which the plants can grow normally and be harvested in an attractive and saleable form. The ability of the grower to identify these different insect pests and to use the available methods of coping with them is fundamental to success in growing good crops of these vegetables.

The more important pests are the cutworm, the cabbage moth, the centre grub, the cabbage aphid, the cluster caterpillar, and the corn ear worm. Minor pests usually kept in check by measures applied for the control of other insects are thrips and the green peach aphid. A recent arrival in the State is the cabbage white butterfly. This insect is well known in other countries as an important pest of cabbages, and it may eventually assume a similar status in Queensland. The destructive stages of the insects and the damage caused by them may be identified from the following key in which the caterpillar measurements are given for full-grown specimens:—

- (i.) Seedlings collapse at ground level, where the stem is injured; large, greyish-green or greyish-brown, curled caterpillars about  $1\frac{1}{2}$  inches long in the soil .. .. . *Cutworm.*
- (ii.) Terminal bud destroyed; small, pale-yellow caterpillars at the tip of the stem and partially enclosed in webbing .. .. . *Centre Grub.*
- (iii.) Holes eaten in the leaves—
  - (a) Small, green, spindle-shaped caterpillars about  $\frac{1}{2}$  inch long, feeding on the under surface of the leaf .. *Cabbage Moth.*
  - (b) Large, dirty-green to brown caterpillars about  $1\frac{3}{4}$  inches long with wedge-shaped markings on the side of the body, feeding in the heart of the plant; ragged outer leaves .. .. . *Cluster Caterpillar.*
  - (c) Large, green to brown caterpillars about  $1\frac{1}{2}$  inches long, feeding in the heart of the plant; no wedge-shaped markings on the side of the body .. .. . *Corn Ear Worm.*
  - (d) Large, velvet-green caterpillars over 1 inch long, feeding on the leaves .. .. . *Cabbage White Butterfly.*

(iv.) Damaged and curled leaves, but no holes—

- (a) Colonies of small, greyish-blue or greenish-yellow insects on the leaves . . . . . *Aphids*.  
 (b) Numerous small, active insects on the lower surface of the leaves; silvering of the leaf surface where insects occur . . . . . *Thrips*.

### Cutworm.

As a result of cutworm injuries to the stem at or near ground level, seedlings frequently collapse shortly after they have been transplanted into the field. The cutworms themselves may be found in the soil at the base of the plants and are the larval stages of one or other of some closely-related moths with very similar habits. They normally feed at night on the lower part of the stem in seedlings, but older plants, even if attacked, usually survive. Cutworms (Plate 59) are typically soft, greyish-green or greyish-brown caterpillars, which, when disturbed, curl up in clock-spring fashion. On emerging from egg masses laid by the female moths on the ground under low-growing weeds, the larvae are very small, and growth proceeds for some four to seven weeks until they are about  $1\frac{1}{2}$  inches long. They then pupate in the ground and later change into moths with a wing span of  $1\frac{1}{2}$  inches, dull-brown forewings, and light-coloured hindwings bordered by a smoky marginal band. Leaf damage due to cutworms is rare in cabbages and cauliflowers, though common on some other crops such as tobacco.



Plate 59.  
NEARLY  
FULL-GROWN  
CUTWORM.

Control measures should be applied as soon as seedling losses are noticed; otherwise the proportion of the crop destroyed may be large enough to compel replanting. These measures are very effective and require the use of a Paris green-bran bait, which is prepared as follows:—Thoroughly mix 25 lb. bran and 1 lb. Paris green on a mixing board; dissolve 1 quart of molasses in 1 pint of boiling water, and make up to 2 gallons with cold water; pour this solution on to the mixed Paris green and bran and stir to a moist, uniform, crumbly mash. When Paris green is not obtainable, arsenic pentoxide can be used as the toxic constituent. This alternative bait is prepared as follows:—Dissolve  $\frac{1}{2}$  lb. arsenic pentoxide in 1 pint of boiling water, and similarly dissolve 1 quart molasses in a pint of boiling water; add  $\frac{3}{4}$  gallon of cold water to each of the two solutions and then pour one into the other; next place 25 lb. bran on to a mixing board and pour the molasses and arsenic pentoxide solution on to it; stir to a uniform, crumbly mash. Both baits are distributed along the rows in small heaps about the size of a walnut, and these should be placed close to but not in contact with the plants. The whole area under crop need not be treated; baits in and around the rows where seedling injury has occurred will be adequate. The amount of bait required can be estimated on the assumption that 50 lb. dry bran will make enough bait to treat an acre of ground. A single treatment usually gives control, but a second application should be made if cutworms are still numerous two days later.

### Cabbage Moth.

The cabbage moth (Plate 60; fig. 4) is a small, greyish-brown insect with a body length of about  $\frac{1}{2}$  inch. The peculiar wing pattern is responsible for an alternative name, the diamond-back moth, for, at

rest, dark wedge-shaped colour patches on the upper exposed margin of the roof-shaped wings form a diamond pattern. In crops showing any considerable amount of foliage injury, the moths are invariably present, though they may not be seen until forced to fly when the plants are disturbed. They lay very small, oval-shaped eggs (Plate 60; fig. 1), singly or in pairs on the under side of the leaf, usually near the larger veins. After a few days—the period varies with the temperature—very small, colourless, larvae emerge and begin to feed on the under surface of the leaf. As they grow older, they eat holes through the leaf, though still feeding from below. In the later stages of development they occur almost anywhere on the plant, and, in cabbages, even penetrate into and through the compacted leaves forming the edible head. The older larvae (Plate 60; fig. 2) are green in colour, somewhat spindle-shaped, and about  $\frac{1}{2}$  inch long. When disturbed they drop from the leaf and hang in mid-air on a silken thread until danger has passed. On completing the larval stage, usually some five weeks after leaving the egg, they construct a sparsely-woven cocoon (Plate 60; fig. 3) on the under surface of the leaf and pupate within it. After transformation to the adult stage, the moth escapes from both the pupa and the cocoon to mate and initiate another generation.

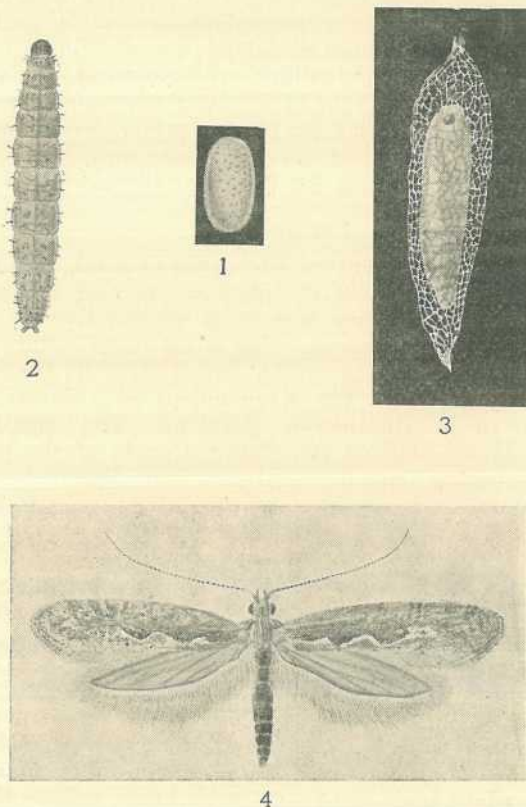

Plate 60.

CABBAGE MOTH: Fig. 1—egg  $\times 25$ ; Fig. 2—larva  $\times 3$ ; Fig. 3—pupa in cocoon  $\times 3$ ;  
Fig. 4—moth  $\times 2$ .

[Drawings by I. W. Helmsing.]

This pest can be found in most crops during the main growing season, and sometimes causes considerable damage, particularly during and after a mild winter when temperatures are not low enough to check its development. Normally the late winter and spring crops on the coast suffer most and, though a grower with successional plantings may escape heavy attacks early in the season, he is unlikely to do so when his later crops begin to mature. The midsummer and later summer crops in the colder districts such as Stanthorpe suffer more heavily than the early summer crops.

Fortnightly applications of lead arsenate in the seed bed and from transplanting to the beginning of heading followed by weekly applications of derris from that time to maturity give good control. The latter product is non-poisonous, and hence no toxic residues remain on the plants when they are harvested. Both insecticides are best applied as dusts, and the lead arsenate dust should contain at least 50 per cent. of the poison, while the derris dust should have a declared rotenone content of at least 1.5 per cent. When derris dust is not procurable, substitute insecticides are a white oil-soap spray, a 1 in 400 nicotine sulphate spray, and a 3 per cent. nicotine dust. The white oil-soap spray is prepared by adding 1 gallon summer white oil to 60 gallons of water in which 4 lb. soft soap has been dissolved; the nicotine sulphate spray is prepared by adding 1 pint of nicotine sulphate to 50 gallons of water in which 2 lb. soft soap has been dissolved; the nicotine dust is marketed as such. The substitute insecticides are somewhat less effective than derris for the treatment of crops in the later stages of growth, and must be applied thoroughly to both sides of the leaves. From the information at present available, the white oil-soap spray appears to be the most serviceable of these substitutes for derris at the present time.

#### Centre Grub.

Though not so important as the cabbage moth, centre grubs, the larvae of another moth, cause at times spectacular damage in coastal cabbage-growing areas. They are most destructive in autumn and seldom affect later planted crops. The adult moth (Plate 61; fig. 4) is rather larger than the cabbage moth and, unlike it, the wings are not roof-shaped when at rest. The wing colour is grey with buff markings arranged in a distinctive pattern. The small, oval eggs (Plate 61; fig. 1) are laid on the younger parts of the plant, and the young larvae hatching from them almost immediately burrow into the centre of the stem at its growing point. The tunnel is usually sealed with frass-cluttered webbing which frequently takes in some of the terminal leaves. This tunnelling may, if the attack is severe, be supplemented by attacks in the main veins of the leaves of older plants. The larva (Plate 61; fig. 2) is a nondescript, pale-yellow caterpillar with seven brownish stripes along the length of the body. When about  $\frac{1}{2}$  inch long, and full-grown, it pupates (Plate 61; fig. 3) within the tunnel where it previously fed, and later transforms into the adult moth. Seedlings in the bed or in the field usually die when attacked, but older plants throw out lateral buds which develop normally if they themselves escape infestation. Even so they cannot produce marketable heads unless the redundant buds are removed by hand, and as this is more or less impracticable on a commercial scale, any plant attacked is essentially a loss to the grower.

The inconspicuous feeding habits of this insect are such that an attack is usually in an advanced stage when first detected. Hence, if

insecticides are applied only when the injury is first seen, treatment will invariably fail to give adequate control of the insect. It is therefore better to regard this pest as a consistent menace to March and April planted crops on the coast and apply a lead arsenate dust to the plants in the seed bed and in the field up to the commencement of heading. From then on the necessity or otherwise for insecticidal treatments can be determined by the leaf injury due to other pests such as the cabbage moth. Weekly treatments with a 50 per cent. lead arsenate dust during the early life of the plant should meet requirements in coastal districts, where, on past experience, the pest is liable to cause trouble. Inland areas such as Stanthorpe usually escape attacks, and no special measures for the control of the insect are necessary there.

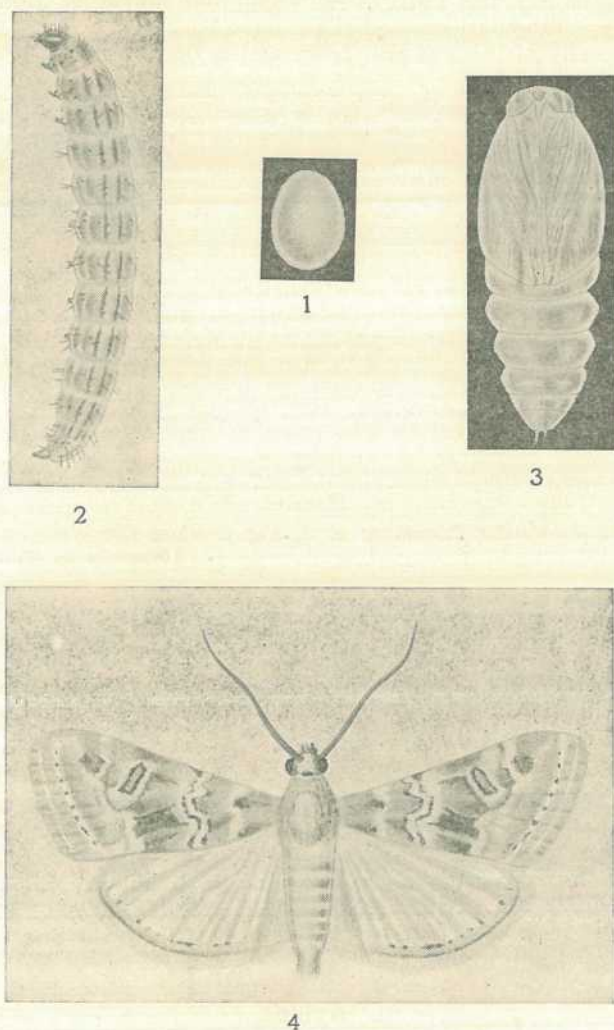

Plate 61.

CENTRE GRUB: Fig. 1—egg  $\times 25$ ; Fig. 2—larva  $\times 5$ ; Fig. 3—pupa  $\times 5$ ;  
Fig. 4—moth  $\times 5$ .

[Drawings by William Manley.]

### Cluster Caterpillar and Corn Ear Worm.

The work of the cluster caterpillar is familiar to coastal growers of cabbages and cauliflowers in Queensland, where the typical damage to the outer leaves caused by the young larvae is quite common. Most of these larvae die, but one or more may survive and penetrate to the centre of the plant and feed inside the head, giving it a ragged appearance. The stages seen by the farmer are the gregarious young larvae on an outer leaf where an egg mass about  $\frac{1}{4}$  inch across and covered with shed body hairs of the parent has been laid, and the solitary more or less mature larva burrowing into and through the head. This latter stage (Plate 62; fig. 1) is about  $1\frac{3}{4}$  inches long, and looks like an abnormally large cutworm, to which it is, incidentally, closely related. Dirty-green to brown in colour, it has dull, black, triangular markings along the side of the body. When full-grown these larvae leave the plant and pupate in earthen cells in the ground, from which the adults later emerge.

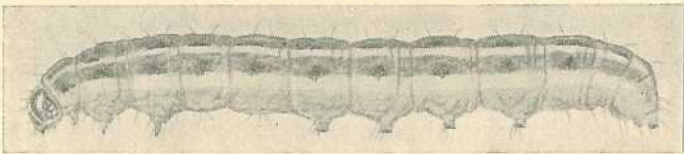

1

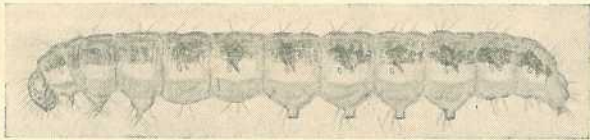

2

Plate 62.

Fig. 1—Cluster Caterpillar  $\times 2$ ; Fig. 2—Corn Ear Worm  $\times 2$ .

[Drawings by William Manley.]

Another insect with somewhat similar feeding habits in the later larval stages is the corn ear worm, better known perhaps as a pest of tomatoes. The full-grown larva (Plate 62; fig. 2), the stage with which the farmer is familiar, is somewhat smaller than the cluster caterpillar, usually lighter in colour, and lacks the triangular marks which the latter has on the side of the body.

It is seldom that either of these pests occur on the cabbage without being associated with more destructive insects for which control measures should be applied. Treatment schedules in which lead arsenate or derris are used will keep the cluster caterpillar in check. Derris has, however, little or no effect on the corn ear worm and, as lead arsenate cannot be applied to the crop after the commencement of heading, little can be done to curb this insect when attacks take place as the crop approaches maturity.

### Aphids.

Two aphids occur on cabbages and cauliflowers in Queensland. They are the cabbage aphid, a small, greyish-blue insect which clusters in dense colonies mainly on the upper surface of the leaves, and the green peach aphid, a larger species with a distinctive greenish-

yellow colour, and somewhat similar habits. Of these, the former is the more important. The cabbage aphid first appears on the leaves in small colonies, which include adults and a variable number of green-coloured young which have not yet acquired the mealy covering characteristic of the later stages. Such a colony may rapidly increase from day to day until the whole plant is a mass of insects (Plate 63). Feeding by puncturing the leaf and extracting the sap, these aphids soon curl the leaves and suppress the development of new growth. In the early stages of an attack some plants may show severe infestation, while others are more or less free from the insects. Later, however, the production of winged females from the earlier established colonies leads to the dispersal of the insect, and almost all plants are then infested, if parasites and predators fail to check the outbreak or control measures are not promptly applied.

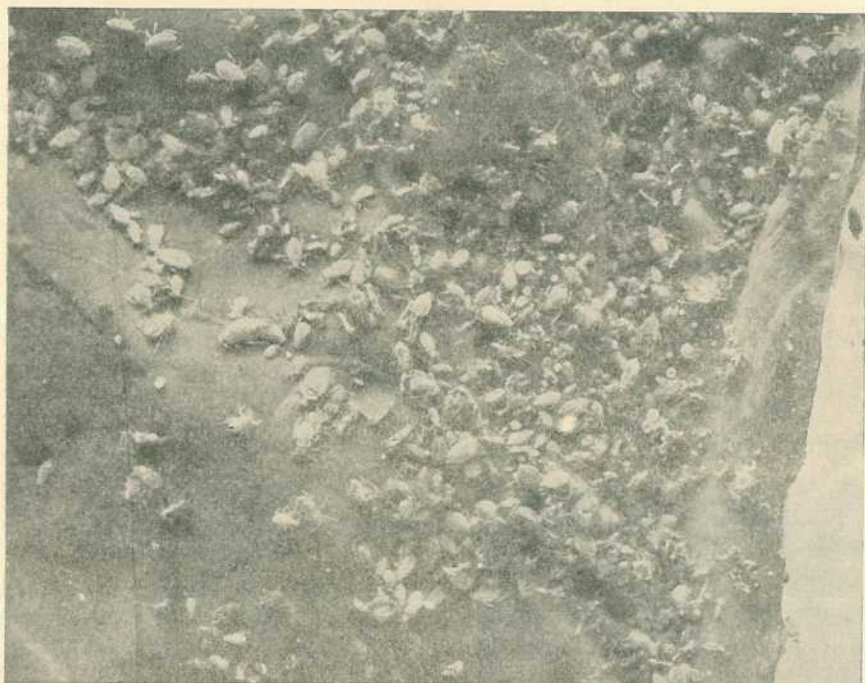

Plate 63.

PORTION OF CABBAGE LEAF INFESTED WITH APHIDS.

Though wasp parasites and various predators destroy numerous aphids in the late stages of an attack, they usually become effective only when the damage is appreciable. A white oil-soap spray, a nicotine sulphate spray, and a nicotine dust destroy both species of aphids. Derris applied for the control of cabbage moth will also keep the cabbage aphid in check. The green peach aphid, however, appears to be more resistant to derris than the cabbage aphid, and when this pest is present in the crop, a nicotine dust, or one of the two other substitutes for derris, should be used to control it.

#### Thrips.

Very small, fringe-winged insects (Plate 64) known as thrips occasionally become so numerous on cabbages and cauliflowers that

control measures are required. These insects feed under the leaves and cause a silverying of the surface, which may later be followed by a breakdown of the leaf tissue, and the suppression of plant growth. When outbreaks occur and require special treatment, a 3 per cent. nicotine dust or the corresponding nicotine sulphate spray should be applied at weekly intervals until the pest has disappeared. As in the case of aphids, these insects are unlikely to be troublesome when contact insecticides are used for the control of cabbage moth.

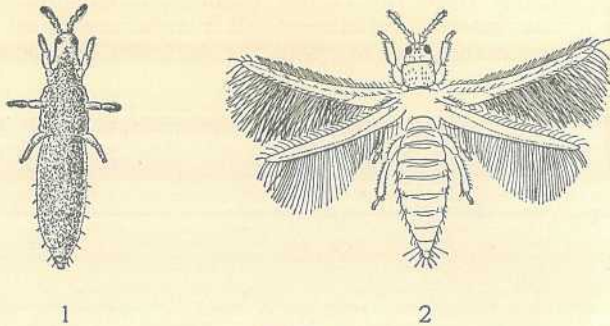

Plate 64.

CABBAGE THRIPS: Fig. 1—larva  $\times 12$ ; Fig. 2—adult  $\times 12$ . While at rest the wings of the adult are folded along the body.

### Cabbage White Butterfly.

A notorious pest overseas, the cabbage white butterfly, has recently been recorded in Queensland, and may become a major pest in the future, though it is not so far known to occur in the main vegetable-growing areas. The moth has a wingspread of  $1\frac{1}{2}$  to 2 inches, and the white wings are ornamented with black tips and one or two black spots, the number of which depends on the sex of the insect (Plate 65). The pale, ribbed vase-shaped eggs are laid singly and hatch within a few days. The larvae grow to more than an inch long, and are then a uniform velvety-green colour. Transformation to the adult takes place in a chrysalis attached to the under surface of the leaf of the plant. The ordinary treatment schedule for the control of cabbage moth should keep this pest in check.

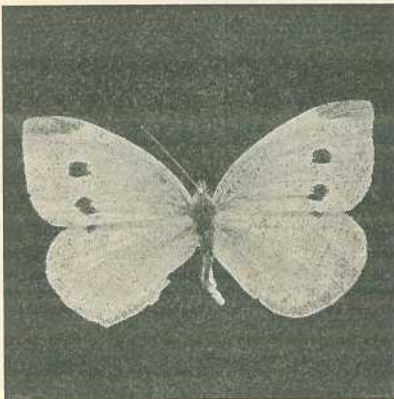

Plate 65.

CABBAGE WHITE BUTTERFLY (actual size).

### Insecticidal Control Measures.

Cabbage and cauliflower growers are seldom concerned with only a single pest, and it is a common practice to apply an insecticidal schedule



which will control those insects which are apt to be more or less troublesome every year, the schedule being modified if and when the intrusion of another pest warrants it. In coastal areas suitable schedules are:—

(a) For March and April planted crops:—Lead arsenate dust (50 per cent.) at weekly intervals to the commencement of heading for the control of centre grub, followed by no further treatment unless leaf damage due to cabbage moth or some other leaf-eating insect is seen in the field. If this occurs a derris dust should be applied weekly or fortnightly, depending on the severity of the attack. Should derris not be available, the white oil-soap spray referred to on page 220, a nicotine sulphate spray at a strength of 1 in 400, or a 3 per cent. nicotine dust may be used instead. Any of these alternative sprays will, if applied weekly during the heading period, give reasonable control of most leaf-eating pests as well as aphids.

(b) For May, June, July, and August planted crops:—Apply a 50 per cent. lead arsenate dust at fortnightly intervals in the seed bed and from transplanting until the crop has commenced to head. From then on, a derris dust, or its alternatives, should be used weekly until harvesting begins. In some seasons, pests may be relatively inactive and a certain amount of latitude is permissible, but it should be noted in timing the treatments that failure to check an outbreak in the early stages can easily prejudice the success of control measures applied later on. Regular inspection of the crop is therefore necessary in order that treatment may keep the pest continually under control, otherwise, damage which seems of no great consequence at the time may be followed by blemishes in the head when it is harvested and lessen the returns from the crop.

In the Stanthorpe district, where the centre grub is seldom, if ever, important, early summer crops need only be treated if leaf-eating insects appear on the plants, weekly or fortnightly applications of lead arsenate, derris, or its substitutes, being then applied according to requirements. Summer and autumn planted crops, however, will normally need the same pest control schedule as that applied to crops planted after May in coastal areas.

#### Cultural Control Measures.

Some of the more important pests of the cabbage and cauliflower feed on a considerable number of cultivated and wild plants. Some of these are present on most farms, and the insects can survive for long periods on them. Hence, once the crop is planted, it may not be long before pest populations increase to troublesome proportions if weather conditions are favourable for a rapid increase in numbers. Cultural measures can do much to keep these initial populations at a low level and thereby simplify the pest control problem. The more important of these are:—(a) weed control during both the preplanting and cropping periods; (b) the destruction of crop residues as soon as harvesting is completed; and (c) rotational cropping so that, whenever possible, crops in the cabbage family will not be planted in succession on the same ground.



### The Romney Marsh.

JAS. CAREW, Senior Instructor in Sheep and Wool.

AS the home of the Romney Marsh is the low-lying lands in the coastal marshy districts of Kent, the breed naturally excels all others for country in which conditions are similar. The native breed were large, coarse animals, which when fat dressed up to 160 lb. They were described as having coarse head and limbs, narrow chest and flat sides, but big bellies. They were slow to mature and fatten, and when topped off carried much internal fat, while the fleece was coarse and rather straight considering its length, with a fleece weight of from 6 to 7 lb. Even in their early days, however, the Romney Marsh sheep were rarely retained in their pure state, but were extensively crossed with the Leicester and later with the Lincoln. This crossing improved their form and covering, although their bulk was somewhat reduced. The present-day type (Plates 66 and 67), bears little resemblance to the old type.

Although even now not so symmetrical and well-shaped as many of the other English long-wool breeds, the Romney Marsh sheep possess a deep well-formed body on stout, strong legs. They have a strong constitution, which gives them an advantage over most other breeds in withstanding cold, moist conditions and exposure to wind and rain. These qualities and their comparatively thick skin and hard, dark hoofs, which ensure success under conditions in which other breeds would be likely to fail. They stand exposure to a remarkable degree

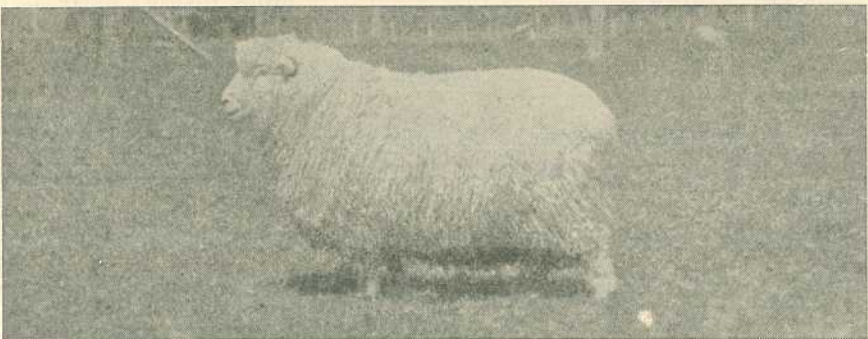

Plate 66.

ROMNEY MARSH RAM AT CHALDON, MALENY.—This ram is from a well-known New Zealand stud. Note typical characteristics—low-set, deep body and full quarters which are all to the good in mutton breeds.

when compared with some of the other breeds, which will hump their backs and refrain from grazing while the Romney Marsh eat their fill and appear contented. This is a valuable characteristic which is of particular importance in our higher rainfall regions.

The Romney Marsh type of the present day may be described as one of the long-woolled, hornless, white-faced breeds, having a broad, massive head, thick but not extensive woolly forelock, thinner between the ears. The ears are thick and large, set down well on the side and covered with white hair. The eyes are large, fairly prominent, mild, with rather a dull heavy look. The nostrils are set well apart, with a dark brown appearance. The neck is thick, fairly long, slightly arched and thick at the base, well set on and tapering slightly at the head, which is not held as erect as in other breeds. The back is straight, long, and wide at the loins, and slightly drooping to the tail; shoulders fairly wide, well set, and level to the back; chest fairly wide and deep; sides rather flat; belly and thighs full and weighty; legs well set apart, thick, strong, and heavy boned, with large feet. The covering is rather straight and open, somewhat lacking in character, and not so long as the Leicester, and is demi-lustre in colour. Rams produce a fleece of about 12 to 15 lb. in weight, having a commanding length of about  $4\frac{1}{2}$  to 5 inches, with a spinning quality averaging from 46s. to 48s.; while the ewes produce a lighter and finer fleece.

As the breed is used largely for crossing with the Merino, its suitability for that purpose is well known and appreciated. The half-bred is a very desirable type, and on small holdings where a dual purpose breeding flock is desired they meet most requirements with satisfaction. Although slower as lambs than the Border Leicester, they develop into well-shaped bulky lambs of good quality. The chief advantage, however, is achieved by bringing the half-bred ewes into the breeding flock. They develop into good, large framed, deep bodied, strongly constituted ewes, docile to handle, and which adapt themselves to small paddocks and cultivated crops, giving a good percentage of lambs with little trouble. They mate most successfully in the late summer and autumn. The cross is most desirable on the lower lands, and stands the heavier coastal humid air better than the other crosses do. They make excellent mothers for the rearing of fat lambs, especially when mated with the quick maturing, compact Downs breeds. As the ewes

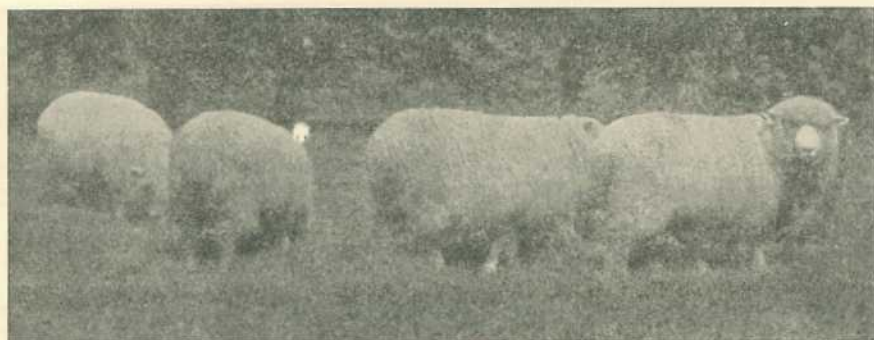

Plate 67.

UNITS OF THE CHALDON EWE FLOCK ON THEIR HOME PASTURE ON THE BLACKALL RANGE (Q.).

are good milkers, the lambs develop quickly. The lambs carry the influence of the sires in form, which fits them with the carcass so desirable for the fat lamb trade.

The flesh of the pure Romney Marsh is coarse and light in colour as compared with the Merino, which is finely grained and darker in colour. The blend of the two breeds results in a carcass rich in colour and fine in texture. Further blending with the Downs type produces the plump quarters which dress to advantage.

In Queensland, at least two Romney Marsh studs have been established, one at Yandilla and the other at Maleny. The Laguna Stud at Yandilla, the property of C. H. Heath, started with high-quality breeding stock of both sexes and later infusions of new blood have maintained a high stud standard. On H. B. Roberts' property, Chaldon, Maleny, a fine breeding flock is steadily building up, the latest introductions including rams from well-known New Zealand stud flocks, and which have already stamped their progeny with characteristics showing excellence in type and quality. The sheep industry in Queensland has already benefited greatly by the enterprise of these two studmasters.

---

## Hints on Sheep Management.

J. L. HODGE, Instructor in Sheep and Wool.

LET us take it that the sheep are "off shears" and the year's operations on the selection are commencing on that basis.

Before leaving the shed, the sheep should be legibly branded with the registered brand. The brand should be properly applied in the allotted position. Frequently, the brand is carelessly placed, sometimes leading to confusion if a few sheep should become boxed with travelling sheep. Care is necessary in a thorough stirring of the branding fluid. If this is not attended to the mixture may be too thin, and the substance of the fluid goes to the bottom of the container.

The allotment of paddocks to the various flocks should receive more attention than is sometimes given to it. For instance, there may be some forward-conditioned wethers which it is desired to dispose of later in the year. These should be drafted out and given a paddock in which they will "top up" at the earliest date. Weaners should be grazed on country free from grass seed and in a paddock in which they will not get "lost." It is a good idea in this connection to allow a few older sheep to go with weaners. Reserve country should be kept in mind for lambing ewes. Attention to all these apparently minor matters makes for the better condition of the whole of the sheep.

### Slack Time Jobs.

Off shears time is the period of greatest liberty with the grazier. Therefore, at this period of comparative slackness, fences should be attended to. Slack wires here and there, the replacement of posts where required, the adjustment of a strainer with a new strut, the hanging

of a gate which has commenced to sag and has become an annoyance—attention to all these things saves time during the year, securely holding the various flocks in their respective paddocks and thus cutting out unnecessary drafting. The water supply, if other than a natural supply, also should receive attention. Windmills should be efficiently overhauled, tanks attended to, and troughing put in complete repair. A few dray loads of stone may be necessary in the approach to a trough.

### Dipping.

If dipping has to be done of necessity, or as part of the yearly operation, on the property, about six weeks after shearing is the time recommended, when they have recovered from the shearing, and all cuts are healed and the six weeks' wool produced gives some slight retention to the dipping mixture. Off shears dipping, although satisfactory as far as the destruction of lice and ked is concerned, leaves something to be desired. Then, there is the risk of arsenical poisoning by absorption in shear cuts, although the retention of the dipping mixture on the skin is very slight.

Every care should be given to the preparation of the dipping bath. One of the proved proprietary mixtures is recommended. Closely follow the direction of the maker as to quantities per 100 gallons. The holding contents of the bath should be accurately known. Prepare a powder dip to the consistency of mixed mustard before adding to the water in the bath. Thoroughly stir from the bottom before putting sheep through.

The choice of the day is important. It should not be too hot. On the other hand, a cold bleak windy day is to be avoided. Sheep should never be dipped while in a heated condition. Give plenty of time to drain. If practicable, dry in the shade. Do not drive sheep long distances, or hurriedly, after dipping. Keep lambs off their mothers long enough to avoid any chance of arsenic poisoning.

### Lambing and Marking.

The time of joining the rams is important. No hard and fast rule may be laid down. Graziers are advised to join at a time proved successful in their particular locality, having in mind a time for dropping when the blowfly is not likely to be prevalent. The period of gestation with sheep is five months. After lambing, the marking of the lambs is an operation which cannot be put off. The best time for marking is when the lambs are a fortnight to three weeks old. The operation embraces the castration of the ram lambs, the removal of the tails of all lambs and the insertion of the registered earmark in the near ear of ewe lambs and the off ear of ram lambs. The work should be done under the most hygienic conditions possible. If there is any doubt about infection in old yards they should not be used, and temporary hurdle yards erected in the paddock in which the lambs and ewes are running. Slitting and tipping are both practised. Of the two, the latter is preferable. It is faster, a consideration where large numbers of lambs are to be treated, and it is thought that the wound drains better. However, for slitting it is rightly claimed that a larger cod is the result. This certainly looks well in a nice even line of wethers.

All knives and earmarkers should be disinfected and dipped frequently in an antiseptic mixture during the work. If blowflies are prevalent, or likely to be, a dressing both disinfectant and curative should be applied to tails and purses.

### Crutching.

By way of making the one muster do, the opportunity should be taken, while the ewes and lambs are in hand, to crutch the ewes. This should be a yearly operation, and should be done particularly well. Crutching certainly costs something, but is a definite deterrent to blowfly strike, and the value of the wool saved is some considerable offset against the cost of the operation. Unless the job is done well it is a waste of time and money.

### Ringing and Wiggling.

After the ewes are dealt with is an opportune time for the ringing and wiggling of the wethers. Then, too, with the sheep in hand may follow the selection of any fats fit for market. In this connection, it is pointed out that it is unprofitable to send sheep to market unless definitely fat. Too often a grazier sends a consignment with only a proportion of fat sheep in the lot. How much more profitable to pick out the fats, and market in this condition, even if it entails sending a number of consignments! Store sheep do not bring their value in competition with fats.

### Weaning.

When lambs attain the age of about five months weaning or the separation from their mothers becomes necessary. Weaners require the best paddock on the property. They feel temporarily the loss of milk to which they are accustomed, even if they were getting very little. In consequence, to maintain condition and grow satisfactorily, they should be well sustained. Beware of a seedy paddock or long grasses where weaners are concerned.

### Culling.

With the near approach of shearing, culling becomes a necessity on a well-managed property. The nearer the fleece is to twelve months' growth the better. Reject from the breeding flock all those ewes which do not conform to the type aimed at. Cull, too, sheep undersized, wrong in conformation, poor doers, and those showing bad hocks and bad faces. With the ewes retained in the flock, the grower would be well advised to join rams of a higher grade selected to "nick" with the type aimed at. Thus, with the retention of the best of the ewes and the purchase of better rams, rapid progress will be made in the achievement of a flock commercially profitable. For some months before shearing, every effort should be made to save the feed in the paddocks near the shearing shed. Some little starving of the flocks is inevitable at shearing time, but a lot can be done to minimise this condition by a little forethought.

### Shearing.

A careful manager does not leave the preparation for shearing until the last minute. There are always a lot of things to do round a shed to ensure a smooth start. Pens may want attention, down chutes must be put in repair, sagging gates in count-out pens and other places fixed, the wool press and ropes overhauled, the machinery seen to, and in fact details too many to mention.

The preparation of the clip is of the utmost importance. Correct classing should be insisted on. A good classer earns far more than the money he gets for the work.

So we have a brief résumé of the twelve months' work on the selection.



## Fodder Conservation.

P. ROUND, Dairy Inspector, Pittsworth.

THE principles of fodder conservation have always been sound, but its practice has often resulted in disillusionment and disappointment. When failures are analysed, however, it is found that the fundamental principles have not been observed. Livestock production, whether it be for meat, milk, or wool, cannot succeed without adequate food for the farm animals. Nature unaided will not provide sufficient sustenance in all seasons. Queensland is fortunate, however, in that hand feeding of stock in most years is only necessary for short periods. It is not proposed to discuss fodder provision for long, dry periods except to suggest the principles laid down may be amplified to reduce the incidence of stock losses during a time of drought.

Dealing specifically with dairying on the Darling Downs, where herds are fed largely on cultivated crops, it is obvious that only limited numbers of cows can be profitably fed. Intense cultivation and dry farming methods practised by progressive farmers have resulted in the production of fodder crops in very adverse seasons. That this alone is not sufficient is evidenced by the recent serious decline in milk production, but if the growing of fodder crops were allied with a practical system of fodder conservation, steady production could be maintained.

Livestock must return a profit for the food consumed. If fodder has to be purchased at drought prices for any length of time, very few classes of stock will repay the outlay. The type of fodder necessary to maintain stock in health and condition is usually the cheapest to grow, but if increased milk production is desired, then the more expensive, protein-rich fodders have to be provided. It is as uneconomical to feed these as a maintenance ration as it is disappointing to feed a merely maintenance ration and hope for greater production.

Fodder conservation may be divided, broadly, into two sections—

- (1) Conservation of enough cheaply-grown fodder to maintain stock in health;
- (2) Conservation of enough high-quality fodder to provide both a maintenance and a production ration.

### The Value of Sorghum.

The quantity of fodder conserved should be based on the number of animals which can profitably be carried on the farm. If a sufficient

area is planted to provide grazing in a lean or even a normal year, a superabundance of fodder will be obtained in a flush season. If a maintenance ration only is desired, sorghum crops are easily the best for the purpose. They provide a heavy tonnage to the acre, which may be conserved either as hay or ensilage. On the Downs, sorghum hay has been opened in perfect condition after fourteen years.

The greatest deterrent to sorghum haymaking is (1) It is heavy work. (2) The stooks have to remain in the paddocks for periods varying from six weeks to three or more months. Much valuable grazing on the stubble is therefore lost, or its use is delayed, and the cultivation of the land also is retarded. These disabilities could be overcome by using reaper binders for delivering the sheaves on to a trailing lorry for transport to an area near the stack yard to be stoked until cured.

Sorghum ensilage was made extensively on the Downs in pre-war years. Ensiled crops leave the stubble and land available for immediate use. The soil on many farms is suitable for trenching, which is the cheapest method of ensiling crops. A large measure of success in handling sorghum crops has been achieved with the ordinary reaper and binder. The main difficulty is labour to load and unload the sheaves. The unloading difficulty has been overcome by some farmers who pull the whole load off the wagons into the trench. Six years experience on one farm alone has proved the value of this method. Another farmer improvised an automatic carrier attachment on his reaper which delivered the crop to a lorry trailing alongside. Consequently, the hardest and slowest part of the work can be mechanised.

Sorghum has been grown and ensiled in the Pittsworth district for less than 5s. a ton. The mechanisation of haymaking for such crops as lucerne, wheat, and oats would greatly lower their cost. With modern haymaking machinery, baled lucerne hay can be produced for £4 a ton in good seasons on suitable land. Grain sorghums are profitably produced and sold on the Downs at less than £5 per ton.

A maintenance ration for a cow would be  $\frac{1}{2}$  cwt. of sorghum ensilage per day, costing approximately 1 $\frac{1}{4}$ d. If a production ration is desired, then the more expensive fodders rich in protein should be added.

A big cow, giving 3 gallons of milk, testing 4 per cent. butter-fat, may be kept up to that production by feeding:—

40 lb. good quality sorghum ensilage at ..	1 $\frac{3}{4}$ d. per day
14 lb. good quality lucerne hay at ..	6d. per day
6 lb. crushed grain approximate at ..	4d. per day
	<hr/> 11 $\frac{1}{4}$ d. <hr/>

Assuming a farmer had—

	£
96 tons of ensilage costing .. .. .	24
25 tons of lucerne hay costing .. .. .	100
10 tons of grain costing .. .. .	50
	<hr/> £174 <hr/>

An allowance of, say, one-third more to cover interest for three years and other sundry expenditure would amount to £58, making the total £232, bringing the feed cost up to 1s. 3d. a day.



The permanent labour on the farm is usually adequate for feeding out, for at periods when feeding becomes necessary, much of the normal work of the farm cannot go on. Taking the average price of milk as 9d. per gallon, a cow producing 3 gallons of milk a day would return 2s. 3d. for the 1s. 3d. worth of feed used. Many dairymen contend that if it costs the whole return to keep fresh cows in production during a short, dry period, it is money well spent, as when green feed is again available, the cows continue in full profit.

Every dairyman knows that to make dairying profitable, cows should produce to their maximum capacity for most of the year. Cows freshening when pasture is scanty often dry off after a few months, with the result that when good milk-producing feed is again available the cows are stale or dry. Consequently, a valuable production is then used merely as a maintenance ration, which is definitely uneconomic. The given quantities of conserved fodder would keep 20 cows in production for six months. Another 106 tons of ensilage would maintain another 20 dry cattle for six months. Some other small incidental expenses may have to be provided for, but the margin of profit would be still wide enough to cover them.

No depreciation need be provided for ensilage. Baled hay will keep for years under cover. Unused grain might have to be turned over annually. When a new crop is assured, the stored grain may be sold. As it is usually in demand at that time, the extra price prevailing would help to offset the loss of weight. Consequently, after the first year, the grain would nearly finance itself.

Farmers depending on cultivated crops for pasture cannot afford to neglect their ploughing and planting operations, and as these are often at their peak when other crops are ready for conserving, the normal labour on the farm is usually inadequate. The most effective way to overcome this difficulty would be co-operative effort between groups and the co-operative use of suitable labour-saving machinery.



Plate 68.

A QUEENSLAND FARM HOMESTEAD.—Mr. J. M. Newman's property, Caboolture.

## The Methylene Blue Test.

C. R. TUMMON, Dairy Inspector.

UNLIKE cream, milk is not graded on taste and smell alone. There is a practical test, called the methylene blue test, now in general use in factories and milk receiving depots, and this test is applied to every farmer's supply. Briefly, methylene blue is a substance which, added to a sample of milk, turns the milk blue. This substance is absorbed by bacteria, and the quality of the milk is judged by the time taken in the absorption of the colouring, the milk afterwards returning to its normal colour. For example, if the colouring takes only a short time (two to three hours) to disappear, it indicates that bacterial contamination is considerable. If it takes much longer (seven to eight hours) for the colouring to disappear, it is an indication that the number of bacteria is very limited and that the quality of the milk may be regarded as good.

Many farmers become worried on receipt of notices from the factory stating that the methylene blue test on their milk was unsatisfactory, and they do not realise the causes, or means of overcoming the trouble. Far too often the blame is attributed to sick cows, rusty cans or other utensils. While these factors may possibly be contributory at times, they are rarely the main cause. The trouble is caused by some important factor or a combination of factors, resulting in a considerable amount of dirt or bacteria getting into the milk at some stage of production or handling.

The following advice is given, therefore, so that farmers may know the likely causes of an unsatisfactory methylene blue test; and also that the remedy lies within their own power:—

- (1) Make sure that no milk from quarters affected with mastitis, or from cows calved within seven days, is used.
- (2) Wash cows' udders thoroughly before milking, using some antiseptic such as Condy's Crystals in the water, and change the water several times in the course of milking. Also wash hands frequently. Boil the udder cloths after each milking. Nothing could be worse than the practice of the "wet" milker who milks cow after cow without washing his hands.
- (3) Reject the first drawn milk from each teat (two or three squirts). This is important. Keep this rejected milk in a separate bucket and feed to pigs or calves. It is better milked into a "strip" cup—(a home-made device would serve). This would serve the added purpose of revealing cows affected with mastitis.
- (4) Use cotton wool filter discs for straining milk. If milk is put into the milk vat and the tap allowed to run slowly all the time into the strainer, which is placed on a can, there will be no delay in waiting for straining. To ensure a rapid flow of milk through the cotton wool filter disc, be sure to use a wide mesh gauze on the strainer, preferably 18 meshes to the inch. A fine gauze strainer (80 mesh) of the kind used for straining milk before separating the cream will not allow rapid milk flow through the cotton wool filter disc.

- (5) Give more attention to the washing of utensils. Provide plenty of boiling water and adopt the following washing-up procedure:—
  - (a) Rinse all cans, buckets, and other utensils with cold water.
  - (b) Follow this with a thorough washing in warm water to which washing soda has been added, using brushes (not cloths).
  - (c) Finally, scald everything with boiling water, and allow to dry without wiping.
  - (d) For cleaning milking machines, caustic soda is preferable to ordinary washing soda. In fact, steam sterilisation should be the final stage of cleansing.
- (6) Another important factor which should not be overlooked is the possibility of manure-dust contamination. Clean up all manure after each milking, and keep manure dust down to an absolute minimum. The holding yard should be cemented, if practicable. As an alternative it should be suitably paved. All manure should be shovelled up while fresh; otherwise, if allowed to dry and become pulverised, it is stirred up by cows in the yard during milking and some must inevitably settle in the milk and on utensils.
- (7) Avoid, if practicable, the use of kerosene tins. In many milking sheds the milk is poured from the bucket into kerosene tins placed in the bails, and at the conclusion of milking these tins are carried into the separator room and the milk poured into the cream cans. This practice means extra work in washing-up, and is often a source of trouble with milk. Unless the seams of kerosene tins are well soldered, they provide an excellent breeding ground for bacteria, in spite of the most careful cleansing. Milk should be tipped straight from the bucket into the milk vat. Straining may then be done when the milk is passed through the tap of the vat into the can.
- (8) Make sure the can is not still hot when milk is delivered into it.
- (9) When milk has to be conveyed long distances it is a definite advantage to aerate and cool the milk over a surface cooler before it leaves the farm.

## PRINCIPLES OF BOTANY FOR QUEENSLAND FARMERS.

Price, 2s., Post Free.

A well-illustrated book containing a fund of useful information about Queensland trees and shrubs, and of practical utility to the man on the land.

Obtainable from—  
The Under Secretary,  
Department of Agriculture and Stock,  
BRISBANE.

## PRODUCTION RECORDING.

List of cows and heifers officially tested by officers of the Department of Agriculture and Stock which have qualified for entry into the Advanced Register of the Herd Books of the Australian Illawarra Shorthorn Society, Jersey Cattle Society and the Ayrshire Cattle Society, production records for which were compiled during the month of July, 1943 (273 days unless otherwise stated).

Name of Cow.	Owner.	Milk Production.	Butter Fat.	Sire.
		Lb.	Lb.	
<b>JERSEY.</b>				
<b>MATURE COW (STANDARD, 350 LB.)</b>				
Kingsford Evelyn .. .. .	F. Z. Eager, Petrie .. .. .	6,446.2	366.819	Oxford Aster's Remus
<b>SENIOR, 3 YEARS (STANDARD 290 LB.)</b>				
Colindale Lotus .. .. .	G. Schroder, Ehlma, Warra .. .. .	9,513.29	456.677	Grasmere Floss 20th Twylish
Gem Marie .. .. .	W. Bishop, Kenmore .. .. .	7,808.7	433.206	Calton Lothean
Mayfair Ruby .. .. .	J. W. Carpenter, Helidon .. .. .	7,038.5	385.951	Trearne Victory
<b>JUNIOR, 3 YEARS (STANDARD 270 LB.)</b>				
Ashview Fancy .. .. .	C. Huey, Sabine .. .. .	5,427.3	321.58	Trearne Butter Queen's Officer
<b>SENIOR, 2 YEARS (STANDARD 250 LB.)</b>				
Elwyn Buttercup .. .. .	E. J. Dunning, Stanmore .. .. .	6,163.55	329.884	Glenside Lone Star
Elwyn Butterfly .. .. .	E. J. Dunning, Stanmore .. .. .	5,962.15	304.022	Glenside Lone Star
Navua Spotted Countess .. .. .	F. Z. Eager, Petrie .. .. .	4,134.75	267.771	Dreamer's Hampton Star
<b>JUNIOR, 2 YEARS (STANDARD 230 LB.)</b>				
Colindale Kitty .. .. .	G. Schroder, Warra .. .. .	6,557.16	332.126	Golden Hill Socks
Lermont Joyful .. .. .	J. Schull, Oakey .. .. .	5,542.9	320.041	Belgonia Lady's Duke 2nd
Lermont Melody .. .. .	J. Schull, Oakey .. .. .	5,473.9	281.422	Woodside Golden Volunteer
Ashview Erin .. .. .	C. Huey, Sabine .. .. .	4,919.35	273.963	Trearne Butter Queen's Officer
Lermont Daisy .. .. .	J. Schull, Oakey .. .. .	5,848.8	270.95	Woodside Golden Volunteer
Lermont Princess .. .. .	J. Schull, Oakey .. .. .	5,004.55	261.239	Woodside Golden Volunteer
Lermont Nancy .. .. .	J. Schull, Oakey .. .. .	5,178.9	250.547	Belgonia Lady's Duke 2nd
Woodview Lady .. .. .	P. H. Schull, Oakey .. .. .	4,866.05	240.935	Lermont Victory
Ashview Countess .. .. .	C. Huey, Sabine .. .. .	3,850.05	238.644	Trearne Butter Queen's Officer
Ashview Chimes .. .. .	C. Huey, Sabine .. .. .	4,978.8	231.71	Trearne Victor 4th
<b>AYRSHIRE.</b>				
<b>JUNIOR, 4 YEARS (STANDARD 310 LB.)</b>				
Leafmore Anita .. .. .	J. P. Ruhle, Motley .. .. .	7,200.65	311.228	Myola Jellicoe

## PRODUCTION RECORDING.

List of cows and heifers officially tested by officers of the Department of Agriculture and Stock, which have qualified for entry into the Advanced Register of the Herd Books of the Australian Illawarra Shorthorn Society, the Jersey Cattle Society, and the Ayrshire Cattle Society, production records for which were compiled during the month of August, 1943 (273 days unless otherwise stated).

Name.	Owner.	Milk Production.	Butter Fat.	Sire.
		Lb.	Lb.	
<b>AUSTRALIAN ILLAWARRA SHORTHORN.</b>				
MATURE COW (STANDARD 350 LB.).				
Edendell Bangle .. .. .	A. Manderson, Gleneagle .. .. .	9,389-35	373-255	Blacklands Chieftain
SENIOR, 4 YEARS (STANDARD 330 LB.)				
Alfa Vale Pansy (365 days) .. .. .	W. H. Thompson, Nanango .. .. .	19,823-5	886-733	Reward of Fairfield
SENIOR, 3 YEARS (STANDARD 290 LB.).				
Trevor Hill Primrose 3rd .. .. .	W. Henschell, Yarranlea .. .. .	12,308-0	474-872	Corunna Supreme
JUNIOR, 3 YEARS (STANDARD 270 LB.).				
Hillfield Pansy 5th .. .. .	W. Caldwell, Bell .. .. .	7,003-0	288-517	Trevlac Leslie
SENIOR, 2 YEARS (STANDARD 250 LB.)				
Ventnor Mab 6th .. .. .	C. W. Black, Kumbia .. .. .	6,289-2	278-484	Kyabram Twinney Boy
Mountain Camp Goldenia .. .. .	W. Caldwell, Bell .. .. .	5,066-24	252-074	Rosenthal Red Major
JUNIOR, 2 YEARS (STANDARD 230 LB.)				
Mountain Camp Reflections Rosette .. .. .	W. Caldwell, Bell .. .. .	5,742-21	254-344	Trevor Hill Reflection
<b>JERSEY.</b>				
MATURE COW (STANDARD 350 LB.).				
Trearne Chimes 3rd .. .. .	T. Petherick, Lockyer .. .. .	7,073-8	411-393	Trinity Some Officer
Trearne Princess .. .. .	T. Petherick, Lockyer .. .. .	6,305-95	384-719	Trinity Some Officer
JUNIOR, 3 YEARS (STANDARD 270 LB.).				
Trearne Chimes 5th .. .. .	T. Petherick, Lockyer .. .. .	5,866-65	353-993	Jerseylea Golden Duke
JUNIOR, 2 YEARS (STANDARD 230 LB.).				
Meadowvale Ginger Girl .. .. .	Young Brothers, Kingaroy .. .. .	5,788-85	312-841	Banyule Altair
Bellgarth Opal 4th .. .. .	D. R. Hutton, Cunningham .. .. .	5,469-83	292-237	Carnation Fair Lad
Trearne Dairymaid 5th .. .. .	T. Petherick, Lockyer .. .. .	4,502-9	272-351	Jerseylea Golden Duke
Lermont Dainty .. .. .	J. Schull, Oakley .. .. .	5,385-8	258-704	Belgonia Lady's Duke 2nd
<b>AYRSHIRE.</b>				
MATURE COW (STANDARD 350 LB.)				
Leafmore Delphine .. .. .	J. P. Ruhle, Motley .. .. .	7,343-75	357-046	Leafmore Clarry



## Feeding Bacon Pigs.

E. J. SHELTON, H.D.A., Instructor in Pig Raising.

**M**ANY of the pigs marketed during prolonged dry periods are not in the prime of condition for slaughter, and when slaughtered their carcasses dress out soft or discoloured, and on grading are classed as of other than first grade. In some instances the fat is soft and oily, and in others of a slightly yellowish colour that will not firm up during the chilling process. If used for small goods, this soft, oily, discoloured meat still carries objectionable features. The loss to the industry through this trouble, plus the lower condition of many of the pigs that kill out to advantage, is very heavy, for it is impossible to expect factories to pay top prices for second or third grade carcasses.

### Over-fat Pigs.

Under Queensland conditions the over-fat pig is a greater problem than any other because there is absolutely no demand for meat carrying an excess of fat, whether it be bacon and ham, pork, beef, mutton, &c., and it does not pay manufacturers to reduce the amount of fat by the process known as "de-fatting," seeing that the value of lard and low-grade fat is low in comparison with first-grade meat.

A typical illustration of this particular trouble came under notice quite recently. The farmer concerned has been marketing bacon pigs for 25 years or more, and has always considered his pigs to be of suitable type. The writer visited his farm some weeks ago and, in discussing the marketing of some baconers approaching the heavy-weight stage so much asked for, suggested that the best and most dependable way of determining whether they were in prime or in over-fat condition would be by having the carcasses judged (appraised) at the bacon factory to which they were to be consigned. This carcass appraisal is carried out by Instructors in Pig Raising, free of charge to the farmer, provided sufficient notice is given beforehand to permit of arrangements being made and, provided the pigs are given an additional brand other than the vendor's usual brand, this to facilitate picking them out on arrival at the factory, and before slaughter. If the pigs are being firebranded they should have a special mark on top of neck or off top of shoulder or an additional tattoo mark on back of neck or on shoulder, plus a paint mark on middle of back, which further facilitates selection before slaughter.

In the case referred to, the inspection of the pigs at the factory before slaughter suggested that while they were well within the

140-180 lb. dressed weight range, they were all over-fat—both the farmer and the trucking agent each had their suspicions that this would be the case—on slaughter. The pigs, 11 in number, were graded, seven as excessively fat, and four as second grade, all the carcasses carrying from a minimum of 2 inches back fat to a maximum (by measurement, not by guesswork) of 2½ inches fat along the loin, back and shoulder. The farmer suffered financial loss, plus the loss of an excessive amount of maize in process of over-fattening.

The simplest way for any farmer to gain definite information is through this appraisal system, which has the additional advantage of permitting inspection of lungs, liver, kidneys, and other organs in search for disease and for parasites, this permitting advice being given regarding management.

Pigs should not be fed too heavily on grain, but be kept growing and be given abundant exercise in grassy pastures. It is a mistake to keep pigs penned up continuously in small sties and bare yards. The use of flesh-forming foods like milk, meat meal, lucerne, greenstuff, &c., and mineral matters will tend to overcome any tendency to over-fatness.

### Soft, Oily Pork.

Although several foods may be responsible for this soft condition, all the evidence points to the fact that the chief cause of the trouble is the feeding of peanuts to pigs which are being prepared for or topped up for the market. Maize and other grain foods are, at present, relatively scarce and very high priced, and as peanuts produce particularly fast growth in pigs, farmers are naturally tempted to use them in place of grain. The position could be relieved if pig raisers would concentrate their peanut feeding on the breeding stock and young pigs, which will make very good use of surplus peanuts, and then other foods available could be kept for the pigs from the weaner stage until they reach bacon weights. Separated milk, root crops, pumpkins, lucerne (either as green fodder, hay, or chaff), and small quantities of pollard, meat meal, and pasture can be used to make up good rations in the absence of maize.

### Yellowish-coloured Pork.

It is known that the probable cause of this condition is an excess of carotin, a colouring matter in plants, and which is present especially during the early life of the plant and at the stage when (as in the case of pumpkins) the crop is fully ripe or over-ripe. The feeding of an excess of green wheat, oats, or barley, in the absence of, or short supply of, milk may also be responsible; so also may the continuous use of grass or of lucerne as the principal food.

### Low-conditioned Pigs.

Lack of condition is, of course, invariably due to lack of sufficient nutritious food. When pigs are in such a condition they become more liable to infestation by internal and external parasites, which irritate the animal and cause much restlessness, especially at night.

It is better to keep fewer animals and to feed them properly than to attempt the keeping of more than the number for which food is available, and it is better to market the pigs when prime to medium weight than to carry them on to heavier weights with loss of condition. Where milk is in short supply meat meal may be used as a substitute, and in

all cases the pigs should have clean drinking water and charcoal. War-time shortages of foodstuffs will have to be overcome on the farm very largely through farmers growing more of their own foodstuffs, just as householders are being urged to grow more vegetables.

### Bruised and Damaged Pigs.

Where pigs are weakened as a result of lack of condition, and where they are soft in texture—the result of improper food—they bruise more rapidly, and tend to be more discontented. The only way to avoid bruising is to have the animals in the prime of condition (not over-fat) and to treat them kindly and not force or beat them when loading or unloading. Avoid knocking them about or forcing them through narrow gateways or over stony rough yards.

The better prices now being offered for all grades of pigs should be an added inducement to farmers to pay more attention to all these details of breeding, feeding, and management.

### Transport Suggestions.

Bacon factory and meatworks managers urge that greater attention should be paid to pigs when trucking by rail, as well as in transit from farm to rail or sale and have emphasised the following points:—

Don't feed pigs on the morning of despatch to sale or to railway trucking yards. They travel better on an empty stomach. Although farmers often think their pigs realise a shilling or two more if they are filled up with feed before despatch, this is a fallacy. Buyers may be deceived sometimes, but they strictly observe the principle of "once bitten, twice shy," and will certainly pay a shilling or two less on future purchases, so the farmer will come off second best in the finish. No bonus is paid on dead pigs.

Trucking pigs overloaded with food results too often in deaths in transit. With the higher values now ruling for bacon pigs, factories cannot pay for dead pigs.

Experiments have clearly demonstrated that it may actually pay to starve pigs for 24 hours before trucking, as this is the greatest preventive of travel sickness and mortality. In these tests pigs fed heavily before despatch lost from 1 to 12 lb. and mortality was much higher than normal.

Don't try to save freight by overloading the wagons, especially during hot and humid weather. A pound or two saved in freight may easily result in a debit of £5 or more because of deaths in transit.

## THE COUNTRYMAN'S SESSION

### Sunday Morning Radio Service to Farmers

(By arrangement with the Australian Broadcasting Commission)

Farmers are recommended to tune in to either a Queensland National or Regional Station.

**EVERY SUNDAY AT 8.30 a.m.**



## Pointers for Pig Farmers.

E. J. SHELTON, Instructor in Pig Raising.

**T**HE pig is a grazing animal and, therefore, does better in a grassy paddock than when kept continuously in a sty.

Cleanliness in all operations is necessary on a pig farm. Buckets and other food containers should be kept clean; troughs should be scoured out regularly and moved frequently on to fresh ground; the milk drum should be regularly emptied and scoured, for the brownish curds that crust around the sides of the milk drum and fall into the milk are definitely poisonous. Milk fluming and piping should be cleansed regularly.

Cleansing of pigsties is a routine job, just as is raking up the yards and burning off rubbish; pig manure and waste bedding should be regularly distributed over cultivation land and be ploughed under and not be allowed to lie in heaps as breeding places for flies and other pests. Pig paddocks should not be allowed to become a harbourage for noxious weeds. Ornamental trees and shrubs provide a very much better shade and protection than weeds, besides adding value to the farm.

Drainage from the pig-feeding ground and from sties and yards should have regular attention and be kept clean and free from weed growth. Water troughs should similarly be regularly cleansed, and fresh water supplied daily.

The farm pig wagon should be washed out on return home from pig sales or trucking yards, and be kept clean and in good order. If a horse-drawn vehicle, the harness, pig net, and other gear should be kept in good order. Pigs will always realise shillings more if they are washed, dried, and are clean before being submitted for sale.

Prompt attention should be given to despatch of pigs sold as breeders, whether crated for rail delivery or personal delivery. The good business man takes advantage of every opportunity for advertising the stock he has for sale, even to printing the name of his farm and its location on the crate and on the address labels.

Prompt advice of despatch, explicit instructions about consigning and paying freight on returned empty crates, punctual posting of pedigrees and prize records are all part of the studmaster's job. Breeder's records should always be kept up to date. These and other business practices carry obviously the hallmark of efficient farm management.

### THE QUEENSLAND AGRICULTURAL AND PASTORAL HANDBOOK.

~~~~~  
Volume III.  
~~~~~

Price, 3s., Post Free.

#### CONTENTS:

- Part I. Insect Pests and their Control.  
Part II. Plant Diseases and their Control.

This publication is indispensable to orchardists, market gardeners, farmers, and agricultural students, but it does not deal with sugar-cane pests and diseases.

~~~~~  
Obtainable from—  
The Under Secretary,  
Department of Agriculture and Stock,  
BRISBANE.

# ANIMAL HEALTH

## Milk Fever and Pregnancy Sickness (*Pregnancy Toxaemia*) of Ewes.

G. R. MOULE, Veterinary Officer.

**M**ILK fever and pregnancy sickness are two conditions which occur in breeding ewes and which closely resemble one another. As it is possible to treat those conditions successfully, it is most important that a correct diagnosis should be made, and the following notes have been compiled to assist graziers in this matter.

### MILK FEVER.

Milk fever is actually a misnomer for this condition, as there is really no fever—*i.e.*, no rise in temperature—associated with this complaint. The disease may occur before, during, or after lambing, but usually trouble occurs close to lambing time.

#### Cause.

Milk fever is caused by a sudden drop in the amount of calcium circulating in the blood. The occurrence of the disease does not indicate that there is an actual deficiency of calcium in the country. In point of fact, the level of the calcium content of the blood is controlled by a special calcium regulating mechanism, and during the time when the young lambs are developing within their dams' bodies or when the first flow of milk is being produced there is often a sudden call on the readily available calcium in the body. The animal body carries a large store of calcium within its bones and when there is a lag period between the mobilisation of the bone calcium and the time of *sudden call* on the *readily available calcium* of the body, milk fever develops.

Observations have shown that milk fever becomes much more prevalent as the age of the ewe flock increases.

#### Symptoms.

1. If the sheep are watched carefully, the first symptom seen is excitement. The ewes become very unsteady on their feet—stagger in their gait—arch their backs, and put their heads out as if in an effort to prevent themselves from falling.

2. When down, some animals manage to rise with great difficulty but if lifted they assume a cramped, crouched attitude, as though their feet were too sore to take their weight. At this stage there is usually considerable trembling of the muscles.

3. If the affected ewe remains down it becomes drowsy and finally unconscious, with glassy eyes and shallow, slow breathing, and appears to be dead. Food is usually regurgitated from the rumen at this stage and the nostrils become clogged. The sick animal then makes a snoring noise when trying to breathe through the nose or else breathes through the mouth.

4. Despite the apparently unconscious condition of the animal it will be found practically impossible to bend the legs, which are usually stretched straight out.

5. Death usually occurs rapidly (*i.e.*, within 24-48 hours) in affected sheep if they are left untreated.

6. When a bad outbreak of milk fever develops, it is usually noticed that the unaffected animals in the flock appear to be drowsy and sleepy.

#### Treatment.

There are two methods of treatment, both of which will bring about spectacular recovery.

1. The obvious treatment is to correct the lowered blood calcium by the injection of a calcium solution under the skin. A suitable solution is prepared by warming the following ingredients until they dissolve in the water:—

Calcium gluconate,  $\frac{1}{4}$ -oz.; Boric acid,  $\frac{3}{4}$ -drachm; Water, 3 oz.

The dose is injected under the skin when the water has cooled to blood heat.

A stock solution of the calcium may be prepared and will keep well if tightly covered. The stock solution can be diluted and used as required. The injection is easily made under the unwooled skin—say, inside the leg—with an ordinary hypodermic syringe. The skin should be cleaned with a little methylated spirits or iodine before the needle is inserted.

An alternative to the above is to purchase calcium boro-gluconate already prepared and use it as a 20 per cent. solution, the dose being 30-50 c.c.s. injected at blood heat as described above.

2. The older treatment, which is quite effective, is to distend the udder of the ewe with air. The air is pumped in with an ordinary bicycle pump, fitted with a special teat syphon. The greatest care must be taken to cleanse thoroughly the teat orifice and the teat syphon before inserting it into the udder. The gland should be only moderately distended after excess milk has been drawn off.

Whichever treatment is adopted, ewes usually recover in from half to one hour, though it is often necessary to distend some ewes' udders with air more than once.

#### Predicting Outbreaks.

Outbreaks of milk fever can usually be expected when pregnant ewes or ewes with lambs at foot are subjected to a period of fasting—*e.g.*, road or rail journeys or ewes held in yards during the pre-lambing, crutching, or jetting operations.

Under paddock conditions, care should be taken when feed is getting short and the ewes are on the down grade—*i.e.*, when the ewes are obviously producing lambs or milk at the expense of their bodily condition.

#### PREGNANCY SICKNESS.

Pregnancy sickness develops during the later stages of pregnancy of ewes. The exact cause of the disease is unknown, but it is known that the nutrition of the sheep does play an important part in its development.

### Predisposing Causes.

It has been observed that sheep on a falling level of nutrition are more likely to develop pregnancy sickness. Sudden changes in diet will also precipitate an attack, as will sudden changes of weather to cold, wet conditions.

Periods of fasting, as when sheep are held in yards for crutching, jetting, or trucking and railing, have also been known to cause trouble, as will periods of fatigue following prolonged exercise—as on a road journey.

### Symptoms.

The symptoms seen are indefinite but may be set down as follows:—

1. The ewes are dull, listless, and appear to be fatigued for several days before the outbreak develops.

2. The ewes are sometimes seen to stand with the head lowered as though they are eating, though there is actually disinclination to eat. Sometimes, on the other hand, the head is held high with the ears drooping.

3. The sight is apparently impaired and the sheep will stagger along with a blundering gait and swinging head.

4. Sometimes there is twitching of the face and ear muscles, grinding of the teeth, and fitlike seizures.

5. The careful observer will notice affected animals are inclined to be constipated, and while urination is normal at first it later becomes suppressed.

6. The offspring is usually alive until the time the ewe dies, though sometimes abortion occurs, and this is usually followed by recovery. If abortion does not occur, death usually supervenes.

### Post Mortem.

Usually, there is nothing definite on post mortem; sometimes the liver is fatty and "soapy" and in many cases there are twin lambs, but this is not always the case.

### Treatment.

The usual treatment recommended is to feed affected sheep large quantities of treacle—from 3 to 6 oz. given two or three times a day.

### Predicting Outbreaks.

Pregnancy sickness can be expected in older ewes, especially if they are poor when pregnancy begins and do not enjoy relief rains during the gestation period, or in ewes fat at joining, but which are subjected to a "pinch" time late in pregnancy. Owners should also bear in mind the predisposing causes—exercise or fatigue, fasting, &c.

### Prevention.

While it is a simple matter to recommend preventive measures which should prove satisfactory for both these conditions, it is often very difficult in the field to apply these recommendations.

Obviously, the circumstances which precipitate these attacks are often beyond the control of the flockowner, though those which are within his control, as prolonged fasting, &c., should be avoided.

### Differential Diagnosis.

When just a few cases are occurring, it is often difficult to decide whether one is dealing with milk fever or pregnancy sickness. Stock-owners should carefully consider the history, symptoms, and the post mortem appearance for comparison. It should be remembered that pregnancy sickness ceases abruptly when lambing starts, whereas milk fever will often go on during and after lambing.

The following summary is useful in differentiating the two diseases:—

#### Milk Fever.

1. Usually abundance of feed, occasionally a sudden scarcity.
2. Road or rail journey or period of fast.
3. Sudden onset with sudden loss of consciousness.
4. Response to udder inflation and/or calcium injections.
5. Persists through lambing.

#### Pregnancy Sickness.

1. History of poor feeding for some time beforehand, sudden change of diet.
2. Road or rail journey or period of fast—sudden climatic changes to cold, wet conditions.
3. Slow onset of symptoms, early loss of appetite, gradual onset of drowsiness, no sudden loss of consciousness.
4. No response to udder inflation and/or calcium injections.
5. Course of disease about 1 week. Stops suddenly with lambing.

When in doubt, it is advisable to treat for milk fever by udder inflation or calcium injection, which give spectacular results with milk fever and will do no harm in pregnancy sickness.

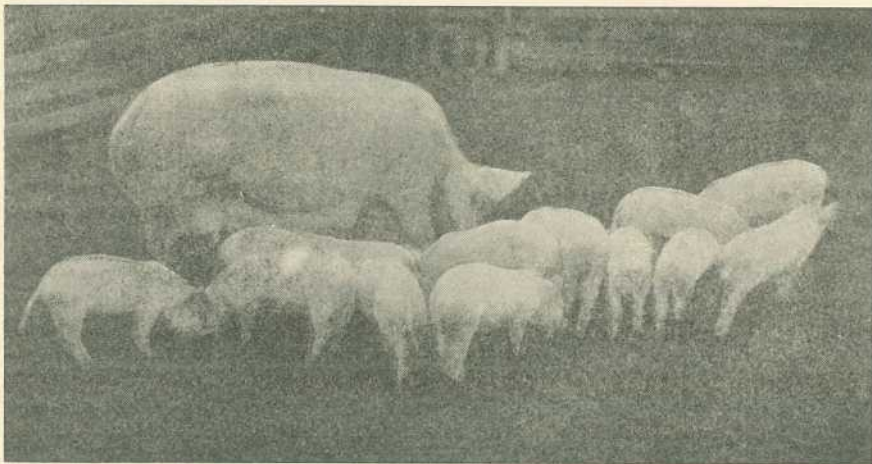

Plate 69.

LARGE WHITE SOW AND LITTER.

## Treat Sheep for Stomach Worm Now!

MARSHALL IRVING, Veterinary Officer.

**T**HE large Stomach Worm, or Barber's Pole Worm, is the chief internal parasite of sheep which will require the attention of graziers during the coming summer and autumn months. This parasite causes severe losses every year after early summer rains, and is, in fact, the biggest disease problem confronting sheepmen on the Darling Downs and Central Highlands. It is always at its worst after the early storms and concurrent periods of warm cloudy weather, when existing infestations are rapidly built up to epidemic proportions. Timely precautions will forestall any serious outbreak during the summer months and make the parasite more easily controllable when later seasonal conditions become just right for its development.

It is advisable to drench from September until late in March, according to weather conditions. If there is a fall of from 40 to 50 points or more of rain spread over several days, or associated with dull, humid conditions, drench about twenty-one days afterwards. If wet weather continues, repeat treatment about every twenty-one days until the weather changes, and give a final drench about twenty-one days after the last wet day.

Therefore, the time to start treatment is NOW. One treatment just before the summer rains (or even immediately after the first storms) will do more to control this parasite than half a dozen later on. Repeat treatments should follow at intervals of two to three weeks after subsequent rains throughout the summer months.

### Drugs Available.

*A wide selection of drugs of varying efficiency and cost is used for the treatment of Stomach worms. These include carbon-tetrachloride, bluestone, bluestone-nicotine, bluestone-arsenic, and phenothiazine. In these days of scarcity, the cheapest and most readily available is the bluestone-arsenic mixture. It costs little more than 2d. per 100 sheep, and is at least as efficient as any of the others, except phenothiazine.*

### Bluestone-arsenic Mixtures.

The bluestone-arsenic mixture may be prepared in several ways; but the most favoured at present is the bluestone-arsenic pentoxide formula which is dispensed as follows:—

Dissolve—

- $\frac{1}{2}$  lb. bluestone, and
- $2\frac{1}{2}$  oz. arsenic pentoxide in
- 3 gallons of water.

Dissolve the arsenic pentoxide in the water; it will dissolve slowly in cold water and rapidly in hot water. Good quality arsenic pentoxide will give a water-clear solution in which the bluestone should be dissolved. Strain the liquid through a cloth before using it. Some grades of arsenic pentoxide on the market do not dissolve completely, but form

a sediment, and are therefore unsuitable for drenching. If sediment is formed, some sheep may be given enough to kill them, and others may not get enough to kill the worms.

Dose rates—

- Grown sheep—1 fluid oz. (or 30 c.c.).
- 12-18 months— $\frac{3}{4}$  fluid oz. (or 25 c.c.).
- 8-12 months— $\frac{1}{2}$  fluid oz. (or 15 c.c.).
- 4-8 months— $\frac{1}{3}$  fluid oz. (or 10 c.c.).
- Under 4 months— $\frac{1}{4}$  fluid oz. (or 8 c.c.).

Over-dosing is dangerous. Under-dosing is inefficient. It is, therefore, important to have accurate scales for weighing the ingredients for efficient and safe drenching. Three (3) gallons of the mixture are sufficient for 480 grown sheep.

It is important to realise that the bluestone-arsenic mixtures give a high degree of efficiency in about 90 per cent. of all sheep. The remaining variable percentage, approximately 10 per cent., in which this treatment fails can be easily recognised as a distinct "tail," and should be drafted off and treated with either carbon-tetrachloride or phenothiazine. This failure is due to the fact that in 10 per cent. of all sheep the bluestone-arsenic mixture does not go direct into the fourth stomach, and so loses its potency by becoming diluted in the contents of the paunch

#### General Control Measures.

Equally important with well-timed drenching is the application of certain general control measures designed to minimise the risks of re-infestation. By far the most important of these is the spelling of paddocks for a period of three to four weeks. By so doing, nearly all the infective larvae in the paddock will die, particularly if the weather is hot and dry, and so sheep which are later introduced will not become re-infested so quickly. Longer spells give little better results. If sheep are alternated from one paddock to another every three to four weeks, more benefit is obtained than by frequently repeated drenching in the same paddock. A change every three to four weeks gives best results, because in that time most infective larvae will die out in the unoccupied paddock, and at the same time none of the worm eggs distributed by the sheep in the occupied paddock can develop to the infective stage during the short period the sheep are present.

Drenching should be governed by prevailing weather conditions, and should be done when the sheep are being moved into a spelled paddock.

Alternation of the sheep from one paddock to another is essential for the control of stomach worms, and has the additional advantage of providing better pasture, and hence better nutrition for the sheep. Such a system in combination with the drenching plan described will ensure better returns in wool and mutton, as well as a substantial reduction of losses.

The use of the correct drench at the right time produces the most benefit for the least expenditure of valuable drugs and labour.

**THE TIME TO START TREATING SHEEP FOR STOMACH  
WORMS IS NOW.**

# Agricultural Chemistry

## Specimens from Dead Animals.

W. R. WINKS, Analyst.

**M**ANY samples of viscera are received for examination by the Agricultural Chemist. Of these, some are altogether unsuitable for analysis. Frequently, the senders request determination of common poisons. This involves long and expensive work. To avoid disappointment and to save both labour and chemicals, the following guide is set out for stockowners and others who submit either portions of dead animals or the materials suspected of causing death for analysis.

1. Animals usually show some symptoms before death. Note these, and if a veterinary surgeon is not available record them and include in any correspondence sent with the specimens. Veterinary surgeons may be able to diagnose the cause from the symptoms described.

2. See if the animal has eaten any plants not usually eaten by stock. This frequently happens in dry times and can be detected by a careful examination of the plants and shrubs in the various paddocks to which the animal has had access. Specimens of suspected plants should be sent with any specimens taken from the animal. Submit leaves, flowers, and fruit when possible.

3. State whether the animals have had access to dips, sprayed plants, or effluents containing poisons.

4. Ask for a determination of the poison suspected. Plant poisons are difficult—frequently impossible—to detect in stomach or intestinal contents. Suspected plants may be identified by the Government Botanist and their possible danger to stock recorded. Do not suggest cyanide, phosphorus, or strychnine poisoning unless any of those poisons have been used in the vicinity.

Cyanide is sometimes used (illegally) to kill possums. It may also be obtained from plants such as sorghums, but evidence of this can easily be obtained.

Strychnine poisoning is rarely found in grazing stock.

Phosphorus is not readily available except in crow or cockroach baits. It may usually be determined if animals have had access to these baits.

*Specimens to send.*—If a post-mortem examination indicates that poisoning is the cause of death, then the following specimens should be sent:—From a ruminant, portions of the paunch and fourth stomach contents are all that are necessary. The paunch sample should be 1 to 2 lb. taken after the contents have been well mixed. Practically the whole of the fourth stomach content should be sent. These should be placed in separate clean tins or bottles and labelled with the name of the specimen and the owner's name and address and despatched to the



Under Secretary, Department of Agriculture and Stock, William Street, Brisbane. A covering letter, with full particulars of the symptoms and suspected cause of death, should be sent at the same time.

If an animal is sick, a sample of the faeces (dung) is useful for the detection of arsenic. The stomach content of dogs, cats, and other domestic animals is all that is necessary for chemical examination.

*Preservatives.*—No preservative is necessary if only stomach contents are forwarded. If organs such as liver and kidney are sent, a little coarse salt may be sprinkled over them if they are likely to be delayed in transit. About a quarter of a-pound of the salt should be forwarded in a separate packet for control analysis.

It should be noted that the foregoing refers to specimens sent for chemical examination and that organs are not required. These are unnecessary, unless legal proceedings are anticipated.

---

### IRRIGATION WATER ANALYSIS.

Although the quality of well water may be suitable for irrigation purposes, it is frequently so high in saline content as to be harmful to growing crops.

The chief salts of well water are those of calcium, magnesium, and sodium. The most injurious of these is generally sodium chloride or common salt.

The quality of the water in some cases alters as pumping progresses, and where the early supply is known to be high in salt content it is advisable to have a sample collected after, say, two hours' pumping and have an analysis made.

This applies particularly to well water adjacent to the sea shore.

—S.J.K.

---

---

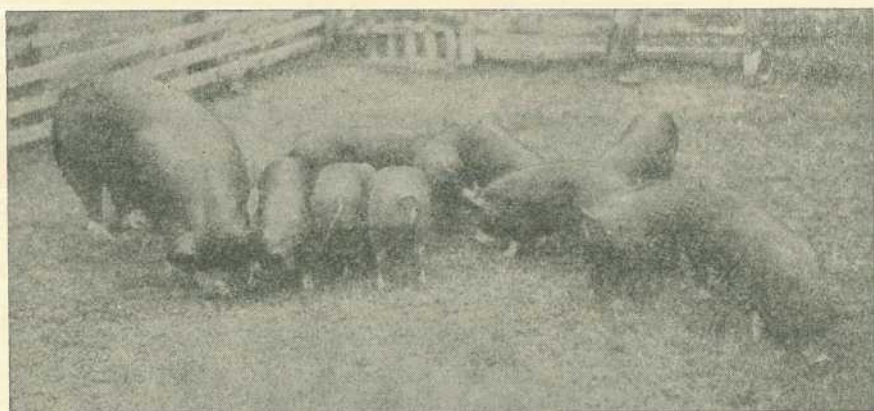

Plate 70.  
BERKSHIRE SOW AND LITTER.

# MARKETING

## Pigmeat Plan Revised.

J. W. GARSDEN, Marketing Branch.

**E**VER-INCREASING demands for bacon and hams have been responsible for revision of the Pigmeat Acquisition Plan. This class of meat is particularly suitable for the Services operating in forward areas which are dependent upon canned and dehydrated meats and preserved meats in the form of bacon and ham for their meat supplies. Action has, in the circumstances, been taken by the Federal Authorities to restrict the sale of all pork, which now may only be disposed of at the direction of the Controller of Meat Supplies. Similar control is exercised over the sale of bacon and ham.

To encourage the production of baconer weight pigs the guaranteed price of pigs for bacon under the plan has been increased by 1d. per lb., bringing the price at export port for first quality to 9d. per lb., with second quality at 8½d., third quality 7d., and excessively overfat 6½d. The price for choppers will remain at 5d. per lb. The new prices, which became operative as from 6th September, are to apply until 30th June, 1945, and will be subject to 12 months' notice before alteration.

Concurrently with the increase in price the upper limit of the weight range of baconer carcasses has been lifted from 180 to 200 lb. The Federal Authorities have also announced that steps are being taken to reduce the cost of wheat for feeding to pigs in the dairying areas to approximately 3s. 6d. per bushel, at the purchaser's siding. However, as the bulk of the wheat for Queensland pig feeders will require to be transported long distances, much of it from southern States, it is not known to what degree Queensland users will benefit.

At the beginning of August a ban was imposed on the slaughter of porker pigs of less than 100 lb. carcase weight. However, as many producers were holding porker types and were encountering difficulties in attempting to carry them to the minimum acceptable weight it was decided to accept porker pigs 100 lb. and under of export standard, i.e., pigs dressing out within the range 82 to 100 lb. and of export quality. Any rejected for export were required to be made available only to the smallgoods trade. The revised pigmeat plan contemplates that the restriction on killings of porkers, except for export, will be maintained and that the price of porkers from 82 to 100 lb. dressed weight will remain at 8d. per lb.

The plan as originally designed had as its main purpose the stimulation of the production of baconer pigs, and to this end aimed at giving stability to the industry. The alterations represent a step further towards this objective. It may be that other changes will occur, and, if so, announcements will no doubt be published in the Press.

Meanwhile there is an urgent demand for a big increase in supplies, and the plan contains an assurance to producers of a stabilised price for baconer pigs over an extended period as its basic principle.

# GADGETS AND WRINKLES

## A GATE WITHOUT HINGES.

The drawing suggests design, construction, and method of mounting a long gate so it will not prove too much for its hinges. A length of 2-inch pipe is used for the backbone of the gate. The bottom of this pipe pivots inside another pipe set into a concrete footing. The top pivots inside a strong strap-iron clevis at the top of the post.

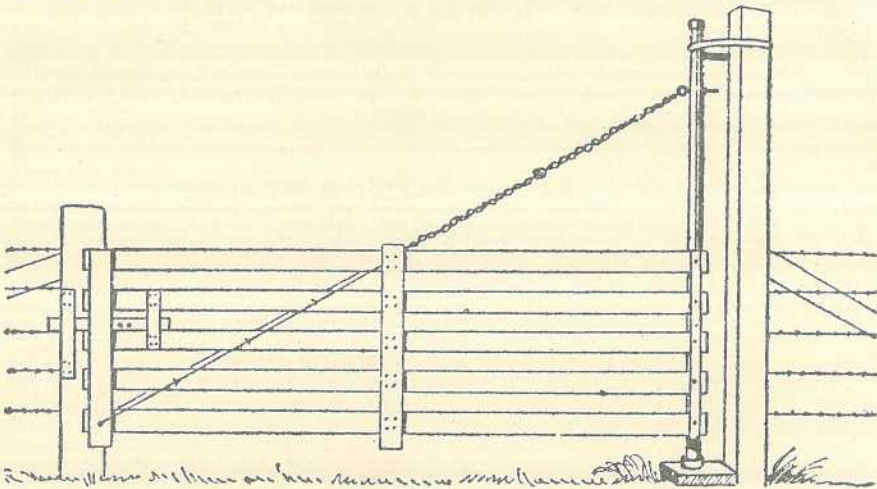

Other specifications differ from this gate somewhat to incorporate ideas used in a roadside gate. One idea is to have the gate shut against the post, rather than to clear it on the inside, and wide enough to permit passage of harrows, dises, and other implements, yet prevent its swinging into the road, where it might be hit by a car.

Four strands of heavy smooth wire may be used as a brace to prevent sag. A bolt near the bottom of the flying end of the gate makes it possible to loop strands to either bolt end, then pass them to the eyebolt through the pipe near its top. Wires may be adjusted to the right tension when the gate is new. Later, when it sags, the nut on the eyebolt may be turned down. Still later the wires above the gate may be twisted to remove additional sag if there is any. The distance between the eyebolt and the iron strap at the top should be enough to permit the pipe to be lifted out of its bottom bearing.

Heavy strap iron should be used, which should be shaped so sides from pipe to post are straight. A 2-inch piece of hardwood then may be cut to fit inside the sides of the strap, which may be drawn tightly against the wood with a bolt. A circular notch for the pipe will hold the top in place so it will not creep inside the iron strap and let the gate end drag when open.

## NAILING WALLBOARD.

In nailing up wallboard covering three or four studdings to the sheet, drive a nail into each stud at the top of the sheet and then hang a plumb line or weighted cord the height of the wallboard on these nails. Nail down along the string.

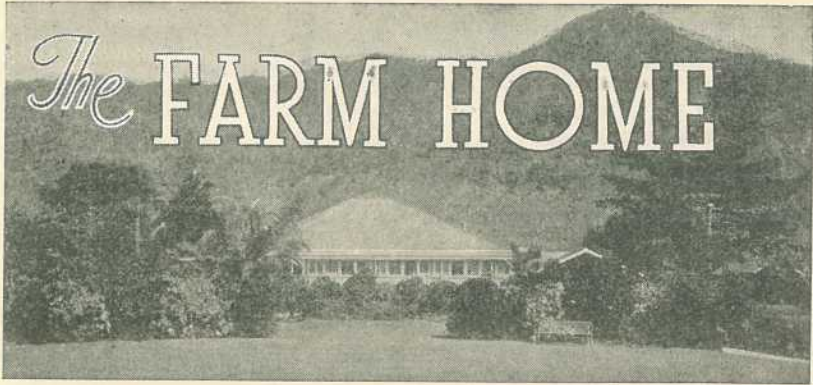

## Care of Mother and Child.

*Under this heading is issued each month an article, supplied by the Department of Health and Home Affairs Maternal and Child Welfare Service, dealing with the welfare and care of mother and child.*

### BABY'S HEALTH: NATION'S WEALTH.

**T**O remain even for half an hour in one of our Welfare Centres is to be impressed by the number of beautiful babies there are. Bright eyes, sturdy limbs, pearly teeth—what an excellent start the children can have nowadays with baby welfare services, radio talks, newspaper and magazine articles all helping the mothers to become “baby-conscious”—to use a popular cliché!

#### What Becomes of Our Beautiful Babies?

In conversation with a young girl recently it was observed that she had at the age of about eighteen years a full set of artificial teeth, and she was complaining of the ache of her feet.

As Herbert Spencer—a well-known philosopher of the last century—said, “This failure to develop and grow up according to early promise causes no surprise or protest—we have got out of the way of expecting the average man or woman to have strong shapely feet, good limbs, deep chest, square shoulders, good muscles, graceful and easy carriage, and the aspect of radiant health and perfection that would be the prevalent type if man took as much trouble and care of his own species as he does about the rearing of cattle and horses. Deformed and crippled feet, spindly calves, indifferent bodies, shallow chests, round shoulders, and slouching gait characterise the majority. Our shortcomings are obvious even to the most casual observer, yet for the most part people regard the present state of matters as normal. There is no general protest against human unfitness. So long as people can manage to struggle through their daily work with the help of occasional patchings up by the doctor and the dentist it does not occur to them that any higher standard than this is to be expected.”

This quotation from a writer of an earlier day can still be applied, unfortunately. Our hospitals are full, so many people go about “not feeling well”—the work of the chiropodist and dentist is increasing rather than decreasing.

In happier times we should have just seen the conclusion of the Brisbane Show—splendid specimens of cattle, sheep, horses, and other farm animals would have been admired by thousands of humans far less well favoured. These “beautiful baby” animals develop into perfect specimens of their breed. Why do we allow our beautiful babies to deteriorate into C.3 adults?

And yet children nowadays should have every opportunity of growing up physically fit. The commercial exploitation of children in factories is now a frightful memory of the past. The State provides for their education and has found that if a child is to learn properly some degree of physical fitness is necessary. Consequently, a school medical service and a dental service have been provided. With the wide scope of the Maternal and Child Welfare Service every mother in

Queensland may obtain help with her baby and child up to school age. Many mothers take advantage of this, especially in respect of advice and help with baby and his feeding, but a lot of mistakes in feeding are made after the baby is a year old and becomes a toddler. Then, again, there is the mother who does not seek help at all, because she has the mistaken idea that "mother knows best," and thinks that a quality vaguely referred to as "mother instinct" will compensate for a thorough knowledge of the correct way to build up the bodies and minds of her helpless little ones.

The revival of breast feeding and the greatly lessened use of artificial feeding during the first nine months of life has lowered the infant death rate in the first year of life by one half, and further progress in this direction would lower it still more. Unfortunately, many mothers plunge into trouble at weaning time, although an increasing number of younger mothers are learning to seek good advice at this time. All this is very hopeful, but there is another, darker side to the picture.

No competent observer can fail to observe the large number of poorly-nourished children. This is seldom due to poverty, but nearly always to want of knowledge, and may be frequently observed among children of the well-to-do. These children are, physically, easily tired; mentally, either dull and listless or unduly irritable and excitable. They fall easy victims to every infection with which they come into contact. Such common infections as measles and whooping cough are not passed through lightly, but leave bad effects behind them. These children grow up candidates for tuberculosis or crippling rheumatism and other conditions of ill health, which fill up half our hospitals. At the root of all this trouble is a diet ill-balanced, unwholesome, and defective in vitamins. Constipation might be called a national disease. Whole industries flourish on this condition, yet of course it grows no less. These industries merely provide temporary aids for crippled bowels. Cripples are not cured by giving them crutches. The main cause of this condition again is defective diet.

School dentists, carefully examining the mouths of children as soon as possible after they enter school, have discovered the alarming fact that, on the average, only one child in ten has teeth without defect. For this again wrong diet is the cause. The diet of babies and their mothers is often deficient in the elements necessary for the development of sound teeth in the first place, and the diet of older children is such as readily destroys what teeth they have. However, it is encouraging to learn that in areas where child welfare centres have been established, and the mothers follow the advice they receive, the school dentists report a noticeable improvement in the children's teeth.

One hundred years ago the foods of our people were on the whole really good. Our grandmothers never worried about vitamins; they had never heard of them, nor had anyone else. But because they ate foods in their natural state they swallowed all the vitamins they needed. Since then our foods have been changed without our noticing it. They are called by the same names, we think they are the same, but some of them are comparatively worthless. New foods have become cheap and popular, though they are worse than worthless.

If parents do not wish their beautiful babies to grow into C.3 citizens they should learn all they can from people qualified to give advice about the feeding of their children from birth until they are fully grown, but especially during their first five years.

Questions on this and any other subject concerning maternal and child welfare will be answered by communicating personally with the *Maternal and Child Welfare Information Bureau*, 184 St. Paul's Terrace, Brisbane, or by addressing letters "Baby Clinic, Brisbane." These letters need not be stamped.

---

## IN THE FARM KITCHEN.

### The Makings of a Square Meal.

*Economy Soup.*—Wash well, scrub, and peel any vegetables it is desired to use (the actual vegetables can be cooked for one meal while peelings, &c., are used to make this soup)—potatoes, carrots, turnips, parsnips, onions, the strings from French beans, the pods of broad beans or young peas, the green tops or outside leaves of celery, a few outside leaves of cabbage, lettuce, silverbeet, or spinach, bacon or rind of bacon. Put them into a saucepan and cover with water, add small pieces of rind of bacon, also rinds of cheese; if no bacon rind is available, use salt or celery salt, a little pepper, 2 or 3 cloves (these may be omitted), some parsley, or a bunch of garden herbs. Simmer gently for about 2½ hours, strain through a sieve or colander

and serve. This is an excellent soup, very nourishing and good for children. Few would suspect its origin, as it is made from materials that are usually thrown away—hence its name. It may be made from the whole vegetables, but they should not be peeled. A tablespoon of wheatmeal or oatmeal added when partly cooked is an improvement, or a few crusts of brown bread. A spoonful of grated cheese sprinkled on a plate of soup adds greatly to its flavour and food value. Dried ends need not be wasted as it grates better when dry.

*French Beans.*—Slice the beans and put into a saucepan with a tablespoonful of butter and about half a cup of water, and a little salt. Steam very slowly until cooked, about three-quarters of an hour. Never use carbonate of soda when cooking vegetables; it destroys the nutriment and also the flavour.

*Preparation of Bean Sprouts or Other Germinated Cereals.*—Bean sprouts or other germinated cereals—useful and nourishing when it is difficult to get green vegetables. Soak some beans, dried peas, barley, or wheat, in cold water in a flat dish over night. Spread them out so as not to cover each other. In the morning drain off the water and cover with a double thickness of butter muslin or old linen, or cotton cloth (not flannel). Keep damp by adding a little water as needed. The sprouts will appear in about 48 hours. They are ready to eat when they are one or two inches long. Bean sprouts are palatable and very nutritious.

Boil or steam the sprouted seeds like any other green vegetable for 15 minutes, adding the salt when nearly cooked. For small children rub them through a sieve. For older children this is not necessary. Serve with white sauce or with a little butter.

*Brown Stew.*—1 lb. shoulder steak or neck of mutton, 1 oz. dripping, 1 onion, 1 oz. flour, 1 pint stock or water, salt, pepper. When fat is smoking hot, add onion chopped or in thin slices, and fry till brown and crisp, take out. Fry meat whole or cut up; when brown, take it out also; pour off any fat there may be in pan; mix flour, seasoning, and water, add; stir till it boils; add meat and onion. Simmer for two to two and a half hours. Neatly cut pieces of carrot, turnip and small onions, or other vegetables may be added.

*Baked Liver and Potatoes.*— $\frac{1}{2}$  lb. to 1 lb. liver,  $\frac{1}{4}$  lb. bacon, 3 or 4 potatoes,  $\frac{1}{4}$  cupful stock or water, 1 dessertspoonful flour, 1 onion, 1 teaspoon dried sage or 3 sage leaves, salt and pepper, 2 teaspoonfuls dripping. Wash liver, dry, cut in slices  $\frac{1}{4}$  inch thick, and dip it in seasoned flour. Cut onion and potatoes in thin slices, and the bacon in small pieces. Grease a pie dish, and put in the different ingredients in layers, having a layer of potatoes on top. Pour in the liquid, and put some pieces of dripping on the potatoes. Cook for about an hour. The tastiness and value of dish are improved if slices of tomato are added.

*Bubble and Squeak.*—Cook cooked cabbage and potatoes, slices of cold meat, pepper and salt; mix cabbage and potatoes together, season with salt and pepper, and fry nicely in hot butter or dripping, about 1 tablespoon; put into the centre of the dish; place in the oven to keep hot; cut slices of any cold meat, fry quickly and lightly; either salt or fresh meat may be used; place the meat round the fried vegetables, with a small roll of fried bacon alternately. May be served without meat.

*Brown Pudding.*— $\frac{3}{4}$  lb. crusts bread,  $1\frac{1}{2}$  oz. suet,  $1\frac{1}{2}$  oz. sugar,  $1\frac{1}{2}$  oz. raisins,  $1\frac{1}{2}$  oz. currants,  $\frac{1}{2}$  teaspoon ground ginger,  $\frac{1}{4}$  teaspoon ground cinnamon,  $\frac{1}{2}$  teaspoon bicarbonate soda,  $\frac{1}{2}$  teaspoon spice (mixed), milk to mix; an egg will improve the mixture. Weigh the bread and soak as long as possible in cold water. Squeeze dry, and crumble with a fork. Chop suet; clean the fruit. Mix all dry ingredients, except soda. Mix it with a little milk, and add to other ingredients. Steam in a greased basin  $1\frac{1}{2}$  to 2 hours, or bake in a greased dish in oven, sprinkling small pieces of suet or butter with sugar and cinnamon on the top.

#### CHANGES OF ADDRESS.

Subscribers are asked to kindly notify changes of address to this Department without delay.