

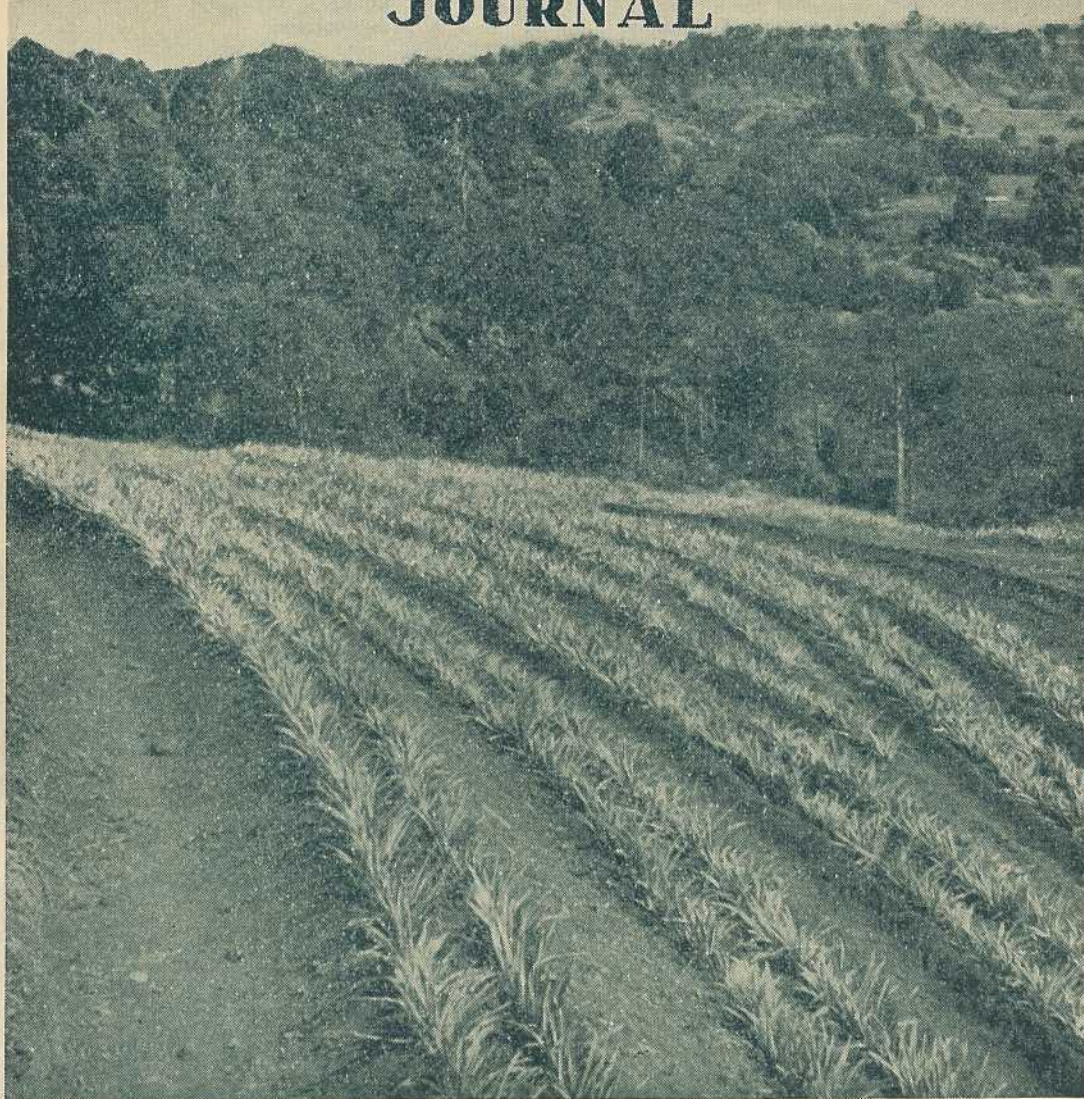

QUEENSLAND AGRICULTURAL JOURNAL



Contour-planted Pineapples, Maroochy Horticultural Experiment Station.

LEADING FEATURES

Soil Conservation in Queensland

Potato Fertilizer Trials

Horticulture on the South Coast

Hints on Making Hives

Control of Cheese Mites

Wool and its Growth

QUEENSLAND AGRICULTURAL JOURNAL

Edited by
C. W. WINDERS, B.Sc.Agr.



APRIL, 1950

Issued by Direction of
THE HONOURABLE H. H. COLLINS
MINISTER FOR AGRICULTURE AND STOCK

Contents

	PAGE.		PAGE.
Soil Conservation—		Beekeeping—	
Soil Conservation in Queensland—		Hints on Making Hives ..	218
3. The Use of Vegetation ..	187	Dairy Industry—	
Field Crops—		Control of Mites at Cheese	
A Progress Report on Potato		Factories and Cold Stores ..	220
Fertilizer Trials	194	Sheep and Wool—	
Fruit Culture—		Wool and its Growth ..	226
Horticultural Districts of Queens-		“The Pest Destroyers Act of	
land—3. The South Coast ..	209	1939”—Registrations ..	235
		Astronomical Data for May ..	247

**FOR QUALITY AGRICULTURAL SEEDS
ALL GOVERNMENT TESTED AND GRADED**

★ ★

BARLEY—Cape BARLEY—Skinless CANARY SEED CLOVERS—White Cert. CLOVERS—Subterranean Cert. LUCERNE SEED—Hunter River Triple Dressed PEAS—Green Feast N.Z. TARES—Golden	BEANS—Can. Wonders BEANS—Brown Beauty COCKSFOOT COW GRASS MANGELS RAPE—Giant Kangaroo RYE GRASS—Italian WHEAT—Ford
--	---

★ ★

BEST SEED OATS

From New South Wales—Graded, Cleaned and Clipped

Algerians — Belars — Mulgas — Fulghums — Sunrise

PRICES, ETC., ON APPLICATION

State Produce Agency Pty. Ltd.

266-274 ROMA STREET, BRISBANE



Soil Conservation in Queensland.

J. E. LADEWIG, Senior Soil Conservationist, and A. F. SKINNER, Soil Conservationist.

3. The Use of Vegetation in Soil Conservation.

PRIOR to settlement, the lands of the State were well covered with vegetation, and under these conditions erosion was limited to a harmless rate. Although it is not possible to restore those original factors and still maintain the present agricultural economy, soil conservation measures must be patterned on the natural conditions which, prior to settlement, reduced erosion to negligible proportions.

This involves the utilisation of close-growing vegetation to the maximum practicable extent in farm operations, the retention of a protective cover on as much of the land as possible for the major part of the year, and the maintenance of the soil organic matter content (Plate 98).

These practices are very effective in controlling erosion because, firstly, they protect the soil from the impact of raindrops, thus ensuring that rain entering the soil is free of soil particles and therefore can penetrate easily; secondly, they check the speed of water flowing on the surface and so reduce its power to transport soil; and thirdly, by increasing the organic matter content of the soil the rapid absorption of rain is facilitated.

Vegetative measures designed to assist in soil conservation are grouped as follows:—

- (1) Crop rotation and strip cropping.
- (2) Cover-cropping and green manure cropping.
- (3) Pasture improvement and management.
- (4) Stubble mulching.
- (5) Tree planting.



Plate 98.

PROTECTION OF THE SOIL WITH VIRGIN FOREST IN THE BACKGROUND AND A COVER CROP IN THE ORCHARD IN THE FOREGROUND.

CROP ROTATION.

Crop rotation may be described as a more or less regular succession of different crops on a single piece of land. The purposes of rotations are to ensure that the minimum area of land will be under clean cultivation conditions at any one time, to assist in the control of weeds, insect pests and plant diseases, and to aid in maintaining soil structure and fertility.

Crop monoculture has been practised extensively in the agricultural areas of this State, primarily because of the greater returns from the main crops suited to the particular districts, but also because this practice simplifies farm management problems. Where systems of one-crop farming have been practised for an extended period, a deterioration in soil structure can be observed, and there has been a progressive decline in the organic matter content of the soil.

The ability of a soil to withstand cultivation for a period of time without serious deterioration in structure depends largely on the colloidal complex, which is influenced by the organic matter content of the soil.

When a natural vegetal cover is present and a soil remains undisturbed, the rates of accumulation and decomposition of organic matter are approximately equal, and usually a slight net increment in organic matter is observed. The greater aeration of the soil resulting from cultivation tends to accelerate the rate of decomposition in warm climates; therefore, though more organic matter may be returned to the soil by cultivated plants or organic material than that derived from

natural vegetal cover, soil under cultivation tends towards a lower equilibrium of organic matter. Until this new and lower level is reached there is a decline in the accumulated humus stocks of the soil.

The inclusion of annual legumes in crop rotation (as green manure or cover crops) will materially assist in the maintenance of soil fertility, because leguminous crops are able to utilise atmospheric nitrogen, and this nitrogen is eventually returned to the soil as additional nitrate; however, since the rate of decomposition is rapid in tropical and semi-tropical zones, a lower organic matter accumulation can be expected from green manure crops in these areas than in the temperate zones.

When cultivated land is retired to semi-permanent pasture the factors favouring organic matter decomposition are arrested, and humus synthesis becomes possible. The structure-destroying effect of farm implements is temporarily removed, and the extensive root development of the pasturage assists in binding the soil aggregates. The short-term (or ley) pasture therefore assumes an important role in a rotational programme for any of the agricultural areas of the State, firstly because of its value in reducing the erosion hazard, and secondly, because it is the most practical method for improving soil structure and increasing soil organic matter.

The essential features, then, in a rotational programme are the inclusion of—

- (1) the main cash producing crop or crops;
- (2) annual leguminous crops for the maintenance of soil fertility and protection of the soil;
- (3) pasture leys for restoration of structure and maintenance of soil organic matter.



Plate 99.

STRIP CROPPING IN THE UNITED STATES.—Cotton is grown in the cultivated strips and cereals in the alternate strips.

[Photo. by U.S. Department of Agriculture.]

STRIP CROPPING.

Strip cropping is a system in which farm crops are planted in relatively narrow strips *on the contour*—that is, across the slope of the land—and so arranged that strips of erosion-inducing crops, such as maize, peanuts, or sunflowers, are separated by strips of dense, erosion-resisting crops such as wheat, cowpeas, oats, barley, lucerne, or pasture (Plate 99). Successful strip cropping requires the adoption of a balanced crop rotation programme.

Careful planning is necessary to make the best use of strip cropping practices and to enable the soil protecting legume-grass strips to be grazed without interfering with adjoining strips of clean cultivated crops. In regions with moderate to high rainfall and where the soils erode readily, strip cropping must be supplemented by contour banks. In contour banked fields the width of strips is usually determined by the bank spacing, but in general, to meet the requirements of soil conservation, the strips of clean cultivated land should not be wider than 100 feet.

COVER CROPS AND GREEN MANURES.

Protective cover crops are important in safeguarding fields from erosion; where land is fallowed during summer months, and is subject to damage by high-intensity summer storms, the use of annual legumes can assist materially in reducing erosion losses, and at the same time help in the maintenance of soil fertility. In this case leguminous cover crops should be sown in early summer to provide protection during the dangerous "storm" months and still allow sufficient time to prepare a satisfactory seed-bed for the sowing of the winter crop.

In fruit-growing areas cover crops may be almost continuously used to avoid the exposure of a bare cultivated surface to erosive agencies. Annual legumes are frequently utilised as cover crops during critical periods and later turned under as green manure crops; their value as cover crops is enhanced by their fertility building value. Legumes used for this purpose include cowpeas, pigeon peas, field peas, lupins, and velvet beans.

PASTURE IMPROVEMENT AND MANAGEMENT.

Native pastures are playing a very important role in protecting grazing lands and the upper slopes of agricultural lands, but there is a vast field for improvement in land utilisation by the retirement of steeper arable land to permanent pastures. Where top-soil losses are serious, pastures, while protecting and improving the soil, will often produce greater returns through grazing than are obtained through cropping such land.

Continuous cultivation of steep lands for the growth of annual forage crops, such as oats, barley, Sudan grass, &c., subjects the land to an unnecessary erosion hazard. Retirement of these areas to permanent pasture will prevent further severe erosion; some initial difficulties may be experienced in the determination of suitable grasses for each district, but adaptable species can be found for areas which it is economically feasible to devote to permanent grass (Plate 100). Departmental officers will provide guidance in respect of these matters.

In medium to low rainfall grazing areas of the State, the effectiveness of pasture management practices is conditioned by the frequency of droughts, and favourable results obtained by careful management may often be lost due to the occurrence of a drought, because all available pasture may be grazed bare in order to keep stock alive over a critical period. Despite this, every effort should be made to adopt pasture management practices which will ensure the maximum utilisation of the protective value of grass and, in particular, to retain as much as practicable of the ground mulch of dry grass. Pasture burning is an invitation to soil erosion, because it not only removes the protective cover of standing grasses but also destroys the valuable cover of grass residues.



Plate 100.

AN IMPROVED PASTURE IN SOUTH-EASTERN QUEENSLAND.—Soil losses are minimised and soil fertility and structure are improved when arable land is retired to this type of pasture for three years in ten.

STUBBLE MULCHING.

Farming techniques in the past have consisted of either the complete "turn in" of crop residues or their destruction by firing. The harmful effects of stubble burning are obvious and lead to the associated decline in soil nitrogen and organic matter, but it is only in recent years that it has been realised that complete burial of crop residues may not be entirely beneficial. The soil organic matter content is only slightly increased by this practice and the crop residues are not being utilised for the protection of the vulnerable soil surface. Recent experimentation has shown conclusively that crop residues must be retained on the soil surface if they are to offer adequate protection. As a result, a new system of agriculture is in the course of evolution. It is known as stubble

mulch farming or sub-surface tillage, in which cultivation operations are carried out without burying more than a limited amount of stubble. Special machinery is being evolved to meet this need, and in wheat-growing districts it will shortly be possible to farm continuously beneath a protective mantle of stubble. Many farmers by adapting existing farm machinery have been able to retain the maximum of trash as a surface mulch with satisfactory results (Plate 101).

The advantages of stubble mulching are obvious. While a surface cover of crop residues can be maintained, high-intensity rains lose much of their danger; the stubble blanket absorbs the energy of the raindrops, which trickle slowly through and are readily absorbed by the soil. Downslope movement of water and soil is impeded by the stubble cover, and moisture losses by evaporation are reduced, enabling crops to survive longer during dry spells.

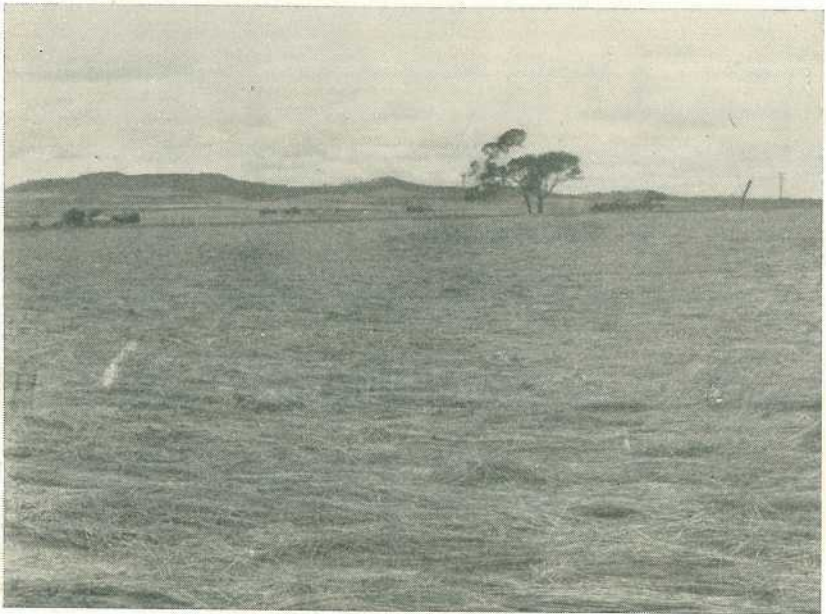

Plate 101.

PERFECT PROTECTIVE BLANKET OF WHEAT STUBBLE AFTER ONE PLOUGHING WITH A SUNDERCUT.—No soil was lost in a 3-inch storm 12 hours before this photo. was taken.

Surface mulching of sloping orchards and vineyards considerably reduces soil and water losses, but in addition will assist in weed control and will ensure the replenishment of the soil organic matter. Under these conditions it is often profitable to grow "stubble" crops in an adjoining area and transport and lay down the mulch by hand. A 4-6 inch depth of mulch is the usual requirement for orchard work to facilitate weed control and to ensure that the process will not have to be repeated too often. Stubble mulching and cover cropping techniques offer the soundest approach to the erosion problem in the steep coastal fruit-growing areas.

TREES.

The comparatively slow rate of erosion in forested areas prior to land settlement is proof of the value of tree cover in preventing erosion. The canopy effect of trees assists considerably in reducing the soil destroying impact of raindrops, but, more important, the mulch cover beneath trees assists water absorption and prevents removal of surface soil. Tree roots bind the soil, and on steep slopes and the sides of water-courses, where the soil can readily slide, tree roots provide the necessary stability. Landslides have often followed the removal of trees on very steep slopes in coastal areas, and the condition can only be corrected by restoring the tree cover.



Plate 102.

FARM WOOD LOT PROTECTING THE HOMESTEAD FROM WIND AND ENSURING A PERMANENT SUPPLY OF TIMBER FOR USE ON THE FARM.

[Photo. by Forestry Sub-Department.

Tree planting, therefore, finds very wide application in soil conservation work. Wood lots (Plate 102) on every farm ensure a permanence of timber and wood supplies, and a protective shelter for birds and other wild life, so necessary to maintain the biological balance in nature.

The complete retention of all trees should be practised on steep slopes and on the sides of watercourses; ringbarking should be restricted to those areas where stability can be achieved without trees. In areas subject to wind erosion shelterbelts of trees are invaluable in reducing the erosion losses, particularly if they are established in lines at right angles to the direction of the prevailing winds.



A Progress Report on Potato Fertilizer Trials.

W. J. CARTMILL, Senior Soils Technologist, Agriculture Branch.

DURING recent years the Department has conducted a series of fertilizer trials with potatoes in the principal potato-growing areas of the State—namely, the Lockyer Valley, the Fassifern Valley, and the Lower Burdekin districts. The object of these trials is to determine the major plant food requirements of the crop for the principal soil types in the various districts, using the yields of first grade potatoes as the basis of the determinations.

PLANT NUTRIENTS ADDED IN FERTILIZERS.

There are at least 12 plant food elements which are essential for the proper nutrition of plants. Some of these are required in relatively large quantities and are referred to as major plant nutrients; others are required in only very small amounts and are referred to as minor plant nutrients. The latter are present in sufficient quantity for plant needs in most agricultural soils and so do not need to be added as a routine fertilizer practice. Indeed, injurious effects on plant growth may follow a too liberal application of some minor elements. Copper, zinc, boron, and iron are examples of minor plant food elements. The plant foods usually added by applications of ordinary commercial fertilizers are three of the major plant foods (namely, nitrogen, phosphorus, and potassium), because deficiencies of these nutrients are most common in soils. The trials reported here were designed to determine whether there are any deficiencies of these three plant foods in the soils of the principal potato-growing areas.

FERTILIZERS COMMONLY USED.

A fertilizer which supplies nitrogen, phosphorus and potassium is commonly called a complete fertilizer, while one which supplies only one of these plant foods is often referred to as a straight fertilizer. Common examples of straight fertilizers are sulphate of ammonia, which supplies nitrogen; superphosphate, which supplies phosphorus; and muriate of potash, which supplies potassium. A complete fertilizer is usually a mixture of straight fertilizers. It is only necessary to use a

complete fertilizer when the soil is deficient in all three of the above major plant foods. Furthermore, it is not wise to apply fertilizers indiscriminately, as best results are obtained when they are used so that the proportions of the three plant foods in the soil are properly balanced. In other words, the amounts of nitrogen, phosphorus and potassium added to the soil should be such as to make the proportion of each present in the soil suitable for the particular crop. These amounts will vary according to the composition of the soil and the requirements of the crop. For example, a soil inherently high in phosphorus might require only nitrogen and potassium, and the addition to it of a fertilizer supplying phosphorus would not only be a wasteful expenditure of fertilizer but might also upset the balance of the nutrients in the soil so that the maximum benefits from additions of nitrogen and potassium might not be obtained.

THE FUNCTION OF FERTILIZERS AND MANURES.

The purpose of using artificial fertilizers is simply to correct any deficiency of the major plant foods in the soil. They do not make up for other deficiencies such as a lack of organic matter or humus, improper preparation or insufficient cultivation of the soil, or for a lack of moisture. Organic matter has an important function in soils: it supplies humus, which, as well as providing plant foods, has an important effect on the structure or tilth of soils, particularly of heavy soils, keeping them loose, open, and friable, and permeable to water. Organic matter greatly improves the water-holding capacity of light soils. The development of a loamy structure or tilth greatly improves the productivity of potato soils, so that the maintenance of a satisfactory humus content should be an integral part of the fertility maintenance programme of potato soils. The loss of humus is partly made good by the additions of large quantities of organic matter, such as by ploughing in bulky green manures and cover crops and by using liberal quantities of farmyard manure; but to build up the organic matter to any appreciable extent it is usually necessary to put the area into grassland for a period. A dense vigorous cover of pasture for a year or two will make a considerable improvement in soils depleted of organic matter. The loss of mineral plant foods such as phosphorus and potassium must be made up by using fertilizers, and it is often necessary to supplement the nitrogen supply by using inorganic nitrogenous fertilizers even though a green manure has been ploughed under.

FIELD TRIALS.

The most satisfactory way of diagnosing the nature and extent of nutrient deficiencies in a soil for any particular crop is by a properly conducted field trial in which the various plant foods are added to the soil in different quantities both alone and in various proportions. In fact, trials of this kind are necessary to determine the amount of fertilizer to add to a soil to give the most profitable crop response.

Because of differences in the fertility of soils due to differences of type it is necessary, in order to determine the fertilizer requirements of the different types, to establish a number of trials on farms scattered throughout the district. To do this the co-operation of farmers is required and the willingness with which this co-operation has been given in establishing these potato trials is much appreciated by the Department.

Although the trials are set out with care and accuracy there are always some which give no useful results because of damage to the crop by certain diseases or some other uncontrollable factor. Only data from trials which are known to be reliable are used for the purposes of interpreting the results.

The results of trials which have been conducted in the various districts over the last four years are discussed below.

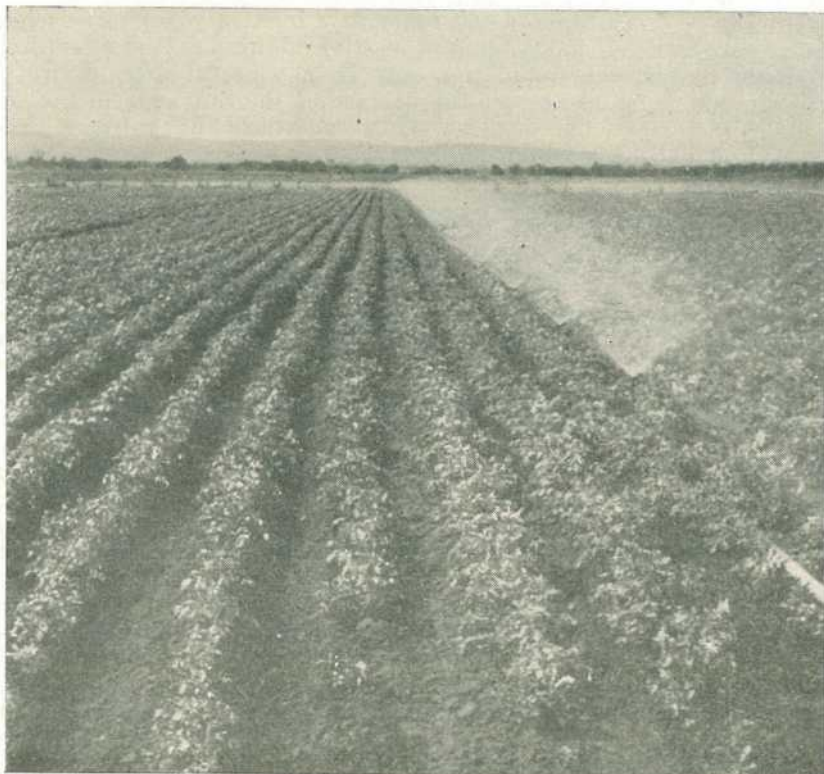

Plate 103.

A POTATO CROP IN THE LOCKYER VALLEY.

TRIALS IN THE LOCKYER VALLEY.

Potatoes are mostly grown in the Lockyer Valley without the use of artificial fertilizers. However, in recent years there has been a growing tendency amongst farmers to apply fertilizers and there is no doubt that in many cases the results have been beneficial. Complete mixtures are mostly used, but it would appear from the results of soil investigations that complete mixtures are not required, while field trials have shown that the beneficial effects of the mixtures can usually be ascribed to only one ingredient of the mixture. Field trials are the ultimate criteria of the soil's fertility status. The Lockyer Valley trials have so far shown that the nutrient which is most frequently deficient in the soils of that district is nitrogen. A few cases of potassium deficiency have been found. Phosphorus, however, appears to be present in ample quantities for plant requirements in all the soils examined.

The results of these trials were as follows:—

Autumn, 1946.

Gatton (M. J. Logan).

The soil type on the site of this trial was a brown-grey alluvial clay-loam. The only response was to sulphate of ammonia, which increased the yield of first grade potatoes by over one ton per acre when it was applied at the rate of 4 cwt. per acre. Superphosphate and muriate of potash had no effect on yield. The result shows that the soil is deficient in nitrogen, but contains sufficient phosphorus and potassium for the needs of the crop.

The mean yields for sulphate of ammonia applications were as follows:—

Sulphate of Ammonia.	First Grade Potatoes.	First and Second Grade Potatoes.
(Cwt. per acre).	(Tons per acre).	(Tons per acre).
Nil	4.43	5.37
2	4.79	5.81
4	5.47	6.51

As the table shows, there was a progressive increase in yield with increasing applications of sulphate of ammonia.

Paree (A. Bachmann).

This trial was carried out on a fairly heavy but friable alluvial soil on Laidley Creek. The response in this case was to potassium. Applications of nitrogen and phosphorus proved to be of no value. The increased yield of first grade tubers from an application of 2 cwt. per acre of muriate of potash was over one ton, which amply repaid the cost of the fertilizer.

Yield data for the muriate of potash applications were as follows:—

Muriate of Potash.	First Grade Potatoes.	First and Second Grade Potatoes.
(Cwt. per acre).	(Tons per acre).	(Tons per acre).
Nil	4.39	4.93
1	4.98	5.50
2	5.45	6.04

It will be seen that there was a progressive increase in yield with increasing applications of muriate of potash.

There was some evidence in this trial that applications of superphosphate lessened the increase in yield due to muriate of potash; that is, that muriate of potash alone gave higher yields than when applied with superphosphate. For example, 2 cwt. of muriate increased the yield by $1\frac{1}{4}$ tons, but when the same amount was applied with superphosphate the increase was below one ton. This latter effect was probably due to a less favourable balance of the plant foods in the soil resulting from the addition of superphosphate.

A further interesting item of information obtained from the trial was that applications of potash greatly reduced the incidence of target spot. The disease was much more severe on the plots to which no muriate of potash had been added. No doubt this was a factor which contributed to the better yields from the potash-treated plots.

Spring, 1946.

Glenore Grove (V. Staatz).

Good responses to applications of sulphate of ammonia were obtained, indicating that nitrogen was deficient in the soil. There was no other deficiency. Superphosphate and muriate of potash made no difference to the yields obtained. Although the response was very pronounced it is interesting to note that only 2 cwt. per acre of sulphate of ammonia was required to give the maximum yield.

Sulphate of Ammonia.	First Grade Potatoes.	First and Second Grade Potatoes.
(Cwt. per acre).	(Tons per acre).	(Tons per acre).
Nil	3.00	4.53
2	4.46	6.10
4	4.33	5.90

The sulphate of ammonia improved the yield of first grade potatoes by nearly 50 per cent.

Tent Hill (A. Jamieson).

Unfortunately this trial was not satisfactorily established. Although certified seed was used the stand of plants in the plots was very uneven and many plants were stunted. In the circumstances the data obtained were unreliable and cannot be regarded as giving a true picture of the fertilizer responses. Because of the poor stand of plants the average yields were low, that for all potatoes being 2.95 tons per acre, of which 2.07 tons were first grade.

Spring, 1947.

Gatton Irrigation Research Station.

The soil on the site of this trial is a grey-brown clay loam which had not been cropped for some years previously, so that its fertility status was probably better than that of an intensively cropped soil of the same type. A high fertility is indicated by the high total yield, which averaged 9.81 tons per acre. The yield of first grade potatoes averaged 5.05 tons per acre, so that nearly half the yield comprised second grade tubers.

There was no response to sulphate of ammonia or to superphosphate, but there was an indication of a response to potash, which is shown particularly in the figures for total yield.

Muriate of Potash.	First Grade Potatoes.	First and Second Grade Potatoes.
(Cwt. per acre).	(Tons per acre).	(Tons per acre).
Nil	4.81	9.33
1	4.96	9.95
2	5.37	10.16

Autumn, 1948.

The autumn 1948 season was a bad one for potato crops in the Lockyer. The conditions favoured the development of *Fusarium* wilt and other diseases, which were severe and general throughout the district. The three fertilizer trials which were established were infected in common with the general crop.

Lockrose (C. Siebel).

This crop was severely infected with wilt. Later, heavy rain in May and June introduced late blight and caused rotting of the tubers. Only about 25 per cent. of the harvested potatoes were sound and marketable, so that the yield figures quoted below are much lower than would have been obtained under more favourable circumstances.

A count of plants affected by wilt at an early stage of the infection showed that the disease was less severe in plots treated with the higher potash application (2 cwt. per acre). Another count a month later showed that all plots were then affected to about the same extent. However, the delay in infection of the high potash plots was sufficient to enable the tubers to develop in those plots, so that they eventually gave the highest yield of first grade potatoes. The yields for the potash-treated plots were as follows:—

Muriate of Potash.	First Grade Potatoes.	First and Second Grade Potatoes.
(Cwt. per acre).	(Tons per acre).	(Tons per acre).
Nil	1.13	2.70
1	1.13	2.52
2	1.43	2.65

The effect of the wilt is shown not only in the low total yield but also in the relatively high percentage of second grade tubers, which represent more than 50 per cent. of the total yield.

Because of the poor crop the yield data cannot be taken as an indication of the response to fertilizer under normal conditions.

Thornton (J. Wilson).

Severe wilt infection was general throughout the plots and considerably reduced the plant population and the resultant yield. Consequently no reliance can be placed upon the data obtained insofar as they indicate soil deficiencies. Although some increased yields were obtained for sulphate of ammonia and for muriate of potash, they were too small to be of any significance. The average total yield of sound potatoes was 4.21 tons per acre, of which 3.26 tons were first grade.

Gatton Irrigation Research Station.

As with the other trials conducted during this season, the crop was severely damaged by wilt. The incidence of the disease was so severe that approximately half the plants in the trial were killed. This reduced the yield and spoilt the value of the trial. The total yield was 3.66 tons per acre, the yield of first grade tubers being 3.18 tons.

Spring, 1948.**Gatton Irrigation Research Station.**

The crop in this trial was planted in a grey-brown clay loam soil after a green manure had been ploughed under. The plants grew well in all plots irrespective of fertilizer treatment. The yield data showed that there was no response to sulphate of ammonia, superphosphate, or sulphate of potash, so that the soil was not deficient in any plant nutrient. It is probable that the green manure contributed to this result, since green manures add nitrogen to the soil and sometimes make other nutrients more readily available. The average yield of first grade potatoes was 4.21 tons per acre and the total yield 5.39 tons.

Mulgowie (W. Litzow).

There was a marked response to sulphate of ammonia in this trial, but no response to superphosphate or sulphate of potash, indicating that the soil was deficient in nitrogen only. Applied at 2 cwt. per acre, sulphate of ammonia improved the yield by about 30 per cent. The higher application made no further improvement.

Sulphate of Ammonia.	First Grade Potatoes.	First and Second Grade Potatoes.
(Cwt. per acre).	(Tons per acre).	(Tons per acre).
Nil	2.79	3.80
2	3.67	4.78
4	3.60	4.86

This trial also showed that superphosphate applied with sulphate of ammonia lessened the beneficial effects of the latter, a higher yield being obtained with straight sulphate of ammonia than with sulphate of ammonia and superphosphate together. For example, with an application of 4 cwt. per acre of sulphate of ammonia without superphosphate the yield increase of first grade potatoes was 1.74 tons per acre; when applied with 3 cwt. of superphosphate the increase was 0.52 tons; and when applied with 6 cwt. of superphosphate the increase was only 0.17 tons per acre. This is another example which illustrates the importance of having the plant foods in the soil properly balanced.

Upper Tent Hill (H. Natalier).

In this trial also there was a response to sulphate of ammonia and no response to superphosphate or sulphate of potash, so that nitrogen again was the only deficiency.

The following mean yield figures show the response to sulphate of ammonia:—

Sulphate of Ammonia.	First Grade Potatoes.	First and Second Grade Potatoes.
(Cwt. per acre).	(Tons per acre).	(Tons per acre).
Nil	4.82	6.05
2	5.33	6.47
4	5.41	6.57

An application of 2 cwt. per acre of sulphate of ammonia increased the yield by more than $\frac{1}{2}$ ton of first grade potatoes. A heavier application was of little further benefit.

Autumn, 1949.

Gatton Irrigation Research Station.

A green manurial crop of wheat and field peas was ploughed in about three months before planting this trial, which was on the same soil type as the previous trials at the station.

Due to heavy rain in February and subsequent rotting of the setts, the trial was replanted in March. However, the incidence of *Fusarium* wilt was again severe this year and about half the plants were infected. As a consequence of the wilt and a virus disease the stand of plants was considerably depleted. Nevertheless, the trial is interesting in that it shows the same trend towards an increase in yield for applications of potash as had been found in a previous trial at this Station (Spring, 1947).

Sulphate of Potash (29 per cent.)	First Grade Potatoes.	First and Second Grade Potatoes.
(Cwt. per acre).	(Tons per acre).	(Tons per acre).
Nil	3.55	4.32
2	3.99	4.77
4	4.01	4.80

No further increase in yield was obtained by applying more than 2 cwt. per acre of the fertilizer.

General Discussion.

The series of trials being conducted in the Lockyer Valley are not yet sufficiently far advanced to give a clear indication of the fertilizer requirements of the Lockyer soils. There are some parts of the Valley that have not yet been covered by trials, while there is no part where a sufficient number of trials has been conducted to give conclusive data. It would be unwise to draw firm conclusions from one or two trials, because there are several factors which are likely to cause local variations in soil fertility. For example, differences in cultural practices, differences in the periods for which the soils have been cultivated, and variations in local topography could cause fertility differences between farms on the same type of soil. It is necessary, therefore, to conduct three or four trials on each of the principal soil types so as to offset the effects of these local variations. However, where such data as are available from the field trials are considered in conjunction with the information available from analyses of soil samples, certain broad general conclusions can be drawn.

The grey-brown soils of the upper part of the Valley covering the area south of Lockyer Creek between Gatton and Grantham show a general nitrogen deficiency, and on these soils potatoes respond well to applications of sulphate of ammonia. About 2-3 cwt. per acre of the fertilizer seems to be a satisfactory application. Possibly a heavy leguminous green manure crop ploughed in prior to planting the potatoes would satisfy some, if not all, of the nitrogen requirements of the crop, and would confer other benefits on these comparatively light

textured soils. The soils are well supplied with the mineral nutrients phosphate and potash in an available form and in field trials have shown no benefits from applications of these plant foods.

Soils somewhat similar in texture and composition occur on Tent Hill, Ma Ma, and Flagstone Creeks, and the available evidence indicates that these soils are also deficient in nitrogen and that potatoes would benefit by applications of sulphate of ammonia. This was shown to be true, for instance, for a field trial at Upper Tent Hill.

The soils in the main part of the Valley are heavier in texture and somewhat variable in composition. Although, in general, they probably have a better nitrogen status than the lighter textured soils, deficiencies of this nutrient are liable to occur, as instanced by the responses to nitrogen obtained in some field trials. However, it is probable that a good leguminous green manure crop would supply the nitrogen requirements of potatoes on these soils.

There are indications that some of these heavier soils may be potash deficient. For example, samples of the Laidley Creek soils in the Laidley-Mulgowie area have been found on analysis to have a low content of available potassium, and potatoes in a field trial in that area responded well to applications of 2 cwt. of muriate of potash per acre. Similarly, soils from some areas in the Lower Lockyer have a fairly low potassium status, and it would not be surprising if these soils respond to potash fertilizers. A trial at Lockrose, for example, showed evidence of such a response.

TRIALS IN THE FASSIFERN VALLEY.

The alluvial soils of the Fassifern Valley closely resemble those of the Lockyer Valley in physical and chemical properties. Similar gradations in texture occur, so that there are some areas where the soils are dominantly good structured friable loams and others where the dominant texture is a light to medium clay. Generally the soils are well supplied with plant foods, though here, as in the Lockyer, a gradual depletion of the organic matter after years of intensive cultivation seems to have resulted in a deficiency of nitrogen in many places, and farmers are now using fertilizers containing nitrogen on an increasing scale.

Although only a few fertilizer trials have been conducted so far in the Fassifern, the evidence obtained strongly suggests a general deficiency of nitrogen in the soils for the potato crop.

Spring, 1946.

Tarome (E. E. Moffatt).

The only response to fertilizer in this trial was to sulphate of ammonia; neither superphosphate nor muriate of potash was of any benefit. Nitrogen was therefore the only nutrient deficient in this soil.

The mean yields from the sulphate of ammonia applications were as follows:—

Sulphate of Ammonia.	First Grade Potatoes.	First and Second Grade Potatoes.
(Cwt. per acre).	(Tons per acre).	(Tons per acre).
Nil	3.89	4.59
2	4.63	5.51
4	4.34	5.31

An application of 2 cwt. of sulphate of ammonia per acre satisfied the deficiency, and no further increase was obtained with the heavier application.

Fassifern Valley (H. Krueger).

There was a marked response to nitrogen also in this trial, though in this case there was a progressive increase in yield with increased applications of sulphate of ammonia. For example, 2 cwt. per acre of sulphate of ammonia increased the yield of first grade potatoes by over $\frac{1}{2}$ ton, and another 2 cwt. further increased the yield by 0.39 tons.

The mean yields were as follows:—

Sulphate of Ammonia.	First Grade Potatoes.	First and Second Grade Potatoes.
(Cwt. per acre).	(Tons per acre).	(Tons per acre).
Nil	4.71	5.78
2	5.26	6.39
4	5.65	6.95

An interesting feature of this trial was that sulphate of ammonia alone gave bigger yield increases than sulphate of ammonia combined with superphosphate. Without superphosphate, the increased yield of first grade potatoes from 4 cwt. per acre of sulphate of ammonia was slightly more than 2 tons; when the same amount of sulphate of ammonia was used with 3 cwt. of superphosphate the yield increase was 0.71 ton; and when used with 6 cwt. of superphosphate only an insignificant increase of 0.03 ton was obtained. This result shows clearly the importance of having the plant foods in the soil properly balanced. An analysis of this soil showed that it is naturally well supplied with phosphate, so that the addition of superphosphate probably made the quantity of this nutrient in the soil excessive in relation to the other nutrients.

Muriate of potash had no effect on yield.

Spring, 1947.

Kalbar (L. Muller).

Here again there was a marked response to nitrogen. In this trial the deficiency was made good by 2 cwt. per acre of sulphate of ammonia, which increased the yield of first grade potatoes by about $\frac{3}{4}$ ton per acre.

Sulphate of Ammonia.	First Grade Potatoes.	First and Second Grade Potatoes.
(Cwt. per acre).	(Tons per acre).	(Tons per acre).
Nil	4.52	6.56
2	5.25	7.45
4	5.34	7.40

As was found for some other trials, superphosphate had the effect of lessening the yield increases due to sulphate of ammonia; that is, better results were obtained with straight sulphate of ammonia than with sulphate of ammonia and superphosphate together. For example, when 2 cwt. of sulphate of ammonia was used without superphosphate the increased yield of first grade potatoes was 1.41 tons per acre; when used with 3 cwt. of superphosphate the corresponding increase was 0.70 ton; and with 6 cwt. of superphosphate the increase was only 0.36 ton. This is another example of what occurs when the nutrients in the soil are not properly balanced.

Gap View, Tarome (J. J. Dwyer).

Special interest is attached to this trial because it not only gave large responses to sulphate of ammonia but also responded to superphosphate. The response to both fertilizers increased progressively with increased applications, as shown in the following table.

Treatment.	First Grade Potatoes.	First and Second Grade Potatoes.
	(Tons per acre).	(Tons per acre).
Nil	4.14	6.08
2 cwt./ac. Sulp. of Am. ..	6.31	8.26
4 cwt./ac. Sulp. of Am. ..	7.02	8.93
Nil	4.14	6.08
3 cwt./ac. Superphosphate ..	4.52	6.62
6 cwt./ac. Superphosphate ..	5.17	6.95

The increased yield resulting from an application of 2 cwt. per acre of sulphate of ammonia was over 2 tons per acre of first grade potatoes. Another 2 cwt. of the fertilizer added a further $\frac{3}{4}$ ton to the yield. Superphosphate at 6 cwt. per acre increased the yield by about one ton. The combined effect of 4 cwt. of sulphate of ammonia and 6 cwt. of superphosphate per acre approximately doubled the yield of first quality potatoes.

The response to superphosphate in this trial is regarded as extraordinary because an analysis of the soil showed that it is liberally supplied with available phosphate—more than would be regarded as sufficient for the needs of the crop. Moreover, in all the other trials so far conducted on soils well supplied with phosphates there has been no indication of any response to superphosphate. A likely explanation of this abnormal behaviour is that some plant food, other than phosphate, is deficient in the soil and was supplied unintentionally in the superphosphate. It is found that lucerne, for example, sometimes responds to superphosphate on phosphate-rich soils, but the effect is apparently due to sulphates in the superphosphate.

General Discussion.

All four trials so far conducted in the Fassifern Valley have shown a response to nitrogen, so it is probable that a deficiency of nitrogen is fairly general in the district. In this respect the soils resemble the lighter textured soils of the Lockyer Valley. To remedy the deficiency, nitrogenous fertilizers should be applied, and sulphate of ammonia at 2-3 cwt. per acre can be expected to give satisfactory results. A dense growth of a leguminous green manure would probably also correct the deficiency and incidentally improve the soil in other ways. Since the deficiency of nitrogen has probably arisen through a depletion of the organic matter in the soil as a consequence of years of cultivation, it would be a sound practice to include green manures in a regular rotation in the cropping programme to offset further losses of this important soil ingredient.

Phosphatic fertilizers are not considered to be required. Although one trial did show a response to superphosphate, this result was probably abnormal.

Potash fertilizers have not given any response so far.

TRIALS IN THE LOWER BURDEKIN.

Potatoes had been grown in the Lower Burdekin for some years before the recent world war, but during the war years a rapid expansion of the industry occurred to meet a wartime demand. The importance of the industry has been maintained and the Woodstock-Ayr district now contributes largely to the requirements of the North Queensland potato market. Fertilizers have an important place in the culture of the crop, and based on the results of some early experiments a fertilizer mixture was formulated and adopted as the standard potato fertilizer mixture for the district. This mixture consists of approximately equal parts of sulphate of ammonia and superphosphate and has the approximate formula 10:10:0. In general it has been giving satisfactory results. However, in view of the fact that the soils of the Lower Burdekin are mostly inherently well supplied with available phosphate, as well as potash, but are low in available nitrogen, it was felt that further experimentation over a wide range of soils might well show that some modification of this formula would be justified; and by getting a better balance of plant foods in the soil enable a more profitable net return to be obtained from the use of fertilizer. Accordingly a series of trials designed to give information on the requirements of the potato in respect to the three major plant foods (nitrogen, phosphorus, and potassium) in the principal soil types of the district was commenced in 1946.

1946 Season.

Clare (E. Granshaw and Sons).

This farm is located on a levee bank of the Burdekin River, where the soil type is a light brown-grey fine sandy loam.

No response to fertilizer was obtained in this trial. On the contrary there was an indication that the heavier application of superphosphate caused a small decrease in yield. The mean yield for the plots without superphosphate was 5.12 tons per acre of first grade potatoes and the corresponding yield for those treated with 6 cwt per acre of superphosphate was 4.56 tons.

This trial was set out on an area that had grown potatoes in each of the previous four seasons. Since it is probable that a commercial fertilizer mixture was used each season it is reasonable to suppose that there would be some accumulation of mineral plant food, especially phosphate, in the soil, and this might have had some effect on the results obtained.

1947 Season.

Clare (E. Granshaw and Sons).

In this year a response to nitrogen was obtained which, although not large, was nevertheless significant and more than paid for the cost of the fertilizer applied as sulphate of ammonia at 4 cwt. per acre. The data showed a small progressive increase in yield as the applications of sulphate of ammonia were increased.

Sulphate of Ammonia.	First Grade Potatoes.
(Cwt. per acre).	(Tons per acre).
Nil	3.06
2	3.28
4	3.47

As was found in the 1946 season trial on this farm, the heavier application of superphosphate tended to depress the yield. In the 1947 trial the effect of superphosphate was to offset the beneficial effect of sulphate of ammonia when the two were applied together. For example, 4 cwt. per acre of sulphate of ammonia without superphosphate increased the yield by 0.69 ton; when applied with 3 cwt. of superphosphate the increase was 0.66 ton; but when 6 cwt. of superphosphate was used the sulphate of ammonia made no improvement to the yield.

Potash applications did not have any effect on the yields.

Home Hill (B. Rubiola).

The effect of fertilizers in this trial was not clear, although it was fairly definite that there was no response to sulphate of ammonia. There was evidence that the high applications of superphosphate depressed the yield, as was found in the trials on Messrs. Granshaw & Sons' farm. The mean yields tabulated below illustrate this trend.

Superphosphate.	First Grade Potatoes.	First and Second Grade Potatoes.
(Cwt. per acre).	(Tons per acre).	(Tons per acre).
Nil	5.0	6.3
6	4.6	5.8

The effect of muriate of potash was indefinite, although there was a trend towards an increase in yield when applied at the rate of 1 cwt. per acre. A lighter application at $\frac{1}{2}$ cwt. per acre had no beneficial effect.

1948 Season.

Clare (E. Granshaw and Sons).

This trial gave different results from either of the two previous trials on this farm, inasmuch as neither sulphate of ammonia nor superphosphate had any significant effect, while muriate of potash at the rate of 1 cwt. per acre lessened the yield obtained by the significant amount of $\frac{1}{2}$ ton per acre. The following table shows that the yields were gradually depressed as the muriate of potash applications increased.

Muriate of Potash. (Cwt. per acre).	First Grade Potatoes. (Tons per acre).
Nil	5.23
0.5	4.86
1.0	4.70

As no similar effect for muriate of potash had been shown in the previous trials on this farm it would be unwise to draw any conclusions at this stage on the behaviour of potash in this soil.

Ayr Regional Experiment Station.

The benefits of sulphate of ammonia applications to the grey silt loam soil at the Regional Station were quite definite. The increase in yield for only 2 cwt. per acre of sulphate of ammonia was over one ton per acre of first grade potatoes.

Sulphate of Ammonia. (Cwt. per acre).	First Grade Potatoes. (Tons per acre).	First and Second Grade Potatoes. (Tons per acre).
Nil	3.23	4.33
2	4.32	5.76
4	4.58	6.57

While there was a large increase in yield for 2 cwt. of sulphate of ammonia, a higher application at 4 cwt. per acre only slightly further increased the yield of first grade potatoes but caused a fairly substantial increase in yield of second grade tubers, as is indicated in the third column of the table.

Superphosphate and muriate of potash had no significant effect on yield.

1949 Season.

Ayr Regional Experiment Station.

As in the previous season's trial at this Station, a response was obtained to nitrogen applied as sulphate of ammonia. Again no benefit was derived from applications of superphosphate or muriate of potash.

The responses to nitrogen are shown in the following table:—

Sulphate of Ammonia.					First Grade Potatoes.	First and Second Grade Potatoes.
(Cwt. per acre).					(Tons per acre).	(Tons per acre).
Nil	3.84	4.55
2	4.52	5.41
4	4.88	5.77

From the two trials conducted at the Station it seems clear that the soil there is deficient in nitrogen, but contains sufficient phosphorus and potassium for potatoes. The amount of sulphate of ammonia required to correct the deficiency of nitrogen seems to be between 2 cwt. and 4 cwt. per acre, so that probably 3 cwt. would be about the optimum.

General.

From the results of the trials so far conducted in the Lower Burdekin and reported here, it is evident that the position in regard to the fertilizer requirements of the potato crop needs further clarification. Several more trials must be conducted on a number of different properties before a satisfactory assessment can be made of the nutritional requirements of the various soil types in the district. Although some of the trials have given erratic results, there is some evidence to indicate that nitrogen is likely to be a major plant nutrient deficiency in relation to potatoes in the Lower Burdekin soils. So far added phosphorus has not been shown to be of any benefit, while the effect of potassium is as yet rather vague.

CARE IN POTATO DUSTING.

A warning against using BHC (benzene hexachloride) for protecting potatoes from insect attack, whether the tubers are in the field or in storage, has been issued by the Science Branch of the Department.

The warning is given because, as previously pointed out by the Department, even small amounts of BHC coming into contact with foodstuffs may affect their flavour.

There are a number of dusts now on the market containing mixtures of BHC, DDT and other insecticides, and instances have occurred where mixed dusts containing BHC have apparently been used as substitutes for straight DDT in insect control, with resultant tainting and economic loss.

In advising growers and others concerned to rely solely on straight DDT, it is pointed out that dusting with 2 per cent. DDT has proved widely successful in Queensland in preventing tuber moth damage in stored potatoes.

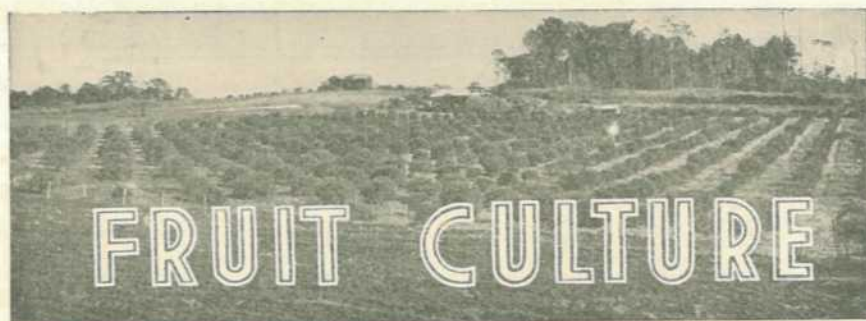

Horticultural Districts of Queensland.

3. The South Coast.

J. MCG. WILLS, Senior Adviser in Horticulture.

THE South Coast horticultural district is a tract of country extending from Coolangatta on the Queensland-New South Wales border to the Logan River some 20 miles south of Brisbane. It is bounded on the east by the Pacific Ocean, on the south by the Macpherson Range, which forms the southern starting point of the Main Dividing Range, and on the west by the Darlington Range. The district is 52 miles long and relatively narrow, with sharp contrasts in elevation (See map). The fertile plateaux of Springbrook, Binna Burra and Beechmont are 1,000 to 2,000 feet high, while the adjacent alluvial flats and coastal plains are only a few feet above sea level. As would be expected from its topography, the district is well watered by several streams and rivers, chief among which are Currumbin Creek, Tallebudgera Creek, Mudgeeraba Creek, and the Nerang, Logan and Coomera Rivers. Some of these creeks and rivers are bordered by extensive alluvial flats in their lower reaches. Between adjacent river systems, high spurs run from the main range towards the sea.

The more important towns are Coolangatta, Currumbin, Burleigh Heads, Southport and Beenleigh. The first four of these lie on the sea front and attract large holiday crowds from both the north and south. Beenleigh is further inland, more typically rural and serves the requirements of farmers in the northern part of the district.

The broken character of the country and the variety of its soils, aspect and elevation may account for the range of crops which can be grown successfully by farmers familiar with the horticultural needs of each.

CLIMATE.

In common with that of most other parts of southern Queensland, the climate near the coast is sub-tropical without extremes of either heat or cold. At Southport, the mean maximum temperature in January is 84 deg. F., while the mean minimum temperature in July, the coldest month, is 48 deg. The high plateau country is, of course, cool temperate in character. Severe frosts are unusual, but they do occur on the coastal flats, which collect and hold cold air flowing down the ranges

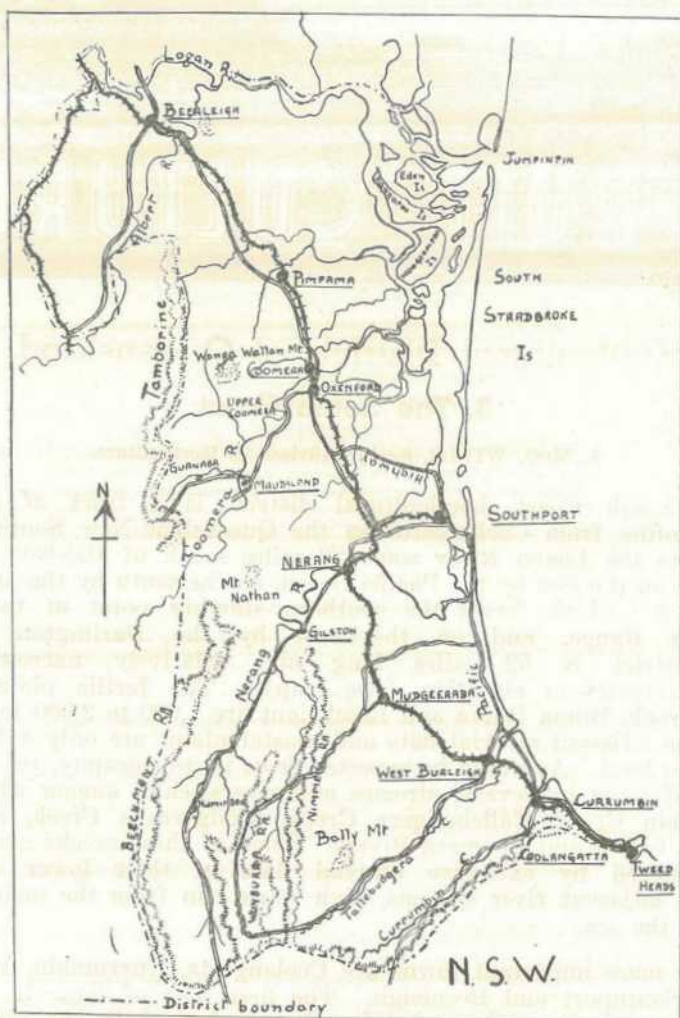

SKETCH MAP OF THE SOUTH COAST HORTICULTURAL DISTRICT.

and associated spurs during the winter months. Some judgment is, therefore, required from the farmer in selecting areas for the cultivation of frost-susceptible plants such as bananas, tomatoes and beans.

The coastal strip has an average rainfall each year of approximately 55 inches, but the plateau and higher spur country may receive twice this amount. Most of the rain falls during the summer period (January to March), winter and spring being relatively dry. The rainfall during the autumn and winter months in many parts of the district is barely sufficient to meet the needs of short-term fruit and vegetable crops, and irrigation facilities considerably reduce normal farming risks at that time of the year.

Heavy rains accompanied by high winds may occur during the monsoonal period of January to April. These can be very destructive on hillside farms if erosion control measures are not practised and the crops are exposed.

Cold westerly winds during the winter months are for the most part diverted from the southern part of the district by the ranges and their associated spurs, but, even so, care is needed in selecting a site for bananas and other crops if cold injury is to be avoided.

Rainfall and temperature observations for Southport are summarised in Table 1.

TABLE 1.
CLIMATIC DATA—SOUTHPORT DISTRICT.

Month.	Mean Maximum Temperature.	Mean Minimum Temperature.	Average Rainfall.
	°F.	°F.	Points.
January	83.8	67.4	715
February	83.2	68.1	676
March	81.2	65.5	802
April	78.2	60.7	535
May	73.0	54.7	528
June	69.3	51.6	366
July	68.9	48.5	307
August	70.9	49.1	207
September	74.4	53.3	273
October	77.8	58.7	280
November	80.9	62.8	364
December	83.0	65.5	498
Yearly average	77.0	58.8	5,551

SOILS.

A variety of soil types is represented in the district. Except where basaltic and other spurs reach to the sea, sand dunes and mangrove swamps are typical of the coast. Behind these lie extensive areas of low, badly drained land carrying a flora of the wallum type. This type of country is not extensively used for horticultural purposes at the present time, but small crops can be grown on the better drained light-grey sands if irrigation is practicable and fertilizers are liberally applied. In some parts of the district, these light, infertile soils edge into shallow, heavy, black clay loams which are intersected by swamps. They overlie an impervious clay band at depths of 8 inches to 1 foot and the water-table is high. Water channels are, therefore, necessary in some areas to ensure adequate drainage. Some of these soils are very fertile, and show peaty characteristics in the vicinity of Merrimac and Pimpama Island. The peaty soils are under pasture at present; the adjacent soils, containing less organic matter, are assigned to agricultural crops such as sugar cane and arrowroot. If irrigation were practicable and drainage adequate, these areas would be very suitable for the production of truck crops. Unfortunately, the plentiful supplies of underground water are brackish and suitable only for stock. There is little possibility of getting good irrigation water from the rivers and creeks, for these are subject to tidal influences for a considerable distance inland. Major irrigation works would be needed to make large-scale irrigation feasible.



Plate 104.

A BANANA PLANTATION ON THE HILLS OF THE UPPER COOMERA.

The production of horticultural crops is, however, located mainly on the loams and clay loams developed on the coastal ranges (Plate 104). The red-brown loams and clay loams derived from sedimentary rocks usually overlie a red-brown clay. These soils are fairly deep and are often strewn with surface boulders. In some areas, such as West Burleigh and on the plateau country, the soils overlie basalt and vary from red clay loams to brown clay loams. They are usually deep and porous and respond well to rain, but dry out fairly quickly. Most of these clay loams erode easily on the steeper slopes and in some areas the topsoil has been lost within a few years of the land being cleared for bananas or some other crop.

While the fertility of the soils on these slopes is good, precautions against erosion losses are essential. Soil management is, therefore, the paramount concern of the fruit and vegetable grower and this may explain the current interest in contour planting, green manuring and drainage problems.

VEGETATION.

Near the coast, the principal timbers are the swamp or semi-swamp species—tea-tree, she-oak, wattle, blue gum and banksia. Towards the foothills, where the rainfall is heavier, the tree cover is very varied, the moist slopes supporting a mixed flora of softwoods and hardwoods in which grey gum, silky oak, blue fig, flooded gum and hoop pine are represented. This semi-jungle carried an undergrowth of vines and has been invaded by lantana, an introduced plant which is very aggressive. The windswept and exposed ridges invariably support forest eucalypts such as bloodwood, ironbark and stringybark in an open forest association.

The basaltic plateau country of the ranges, where the soil is rich and the rainfall heavy, carried rain forest from which a great deal of excellent millable timber has been drawn. The readily accessible areas have now been cleared but the original forest cover still stands in some of the more remote localities as well as in National Parks and catchment zones controlled by water authorities.

HORTICULTURAL USES.

Although most tropical and subtropical fruits can be and are grown on the South Coast, the district is best known as an important banana producing area. The topography of the country is, however, so varied that sheltered frost-free situations are available for other horticultural crops.

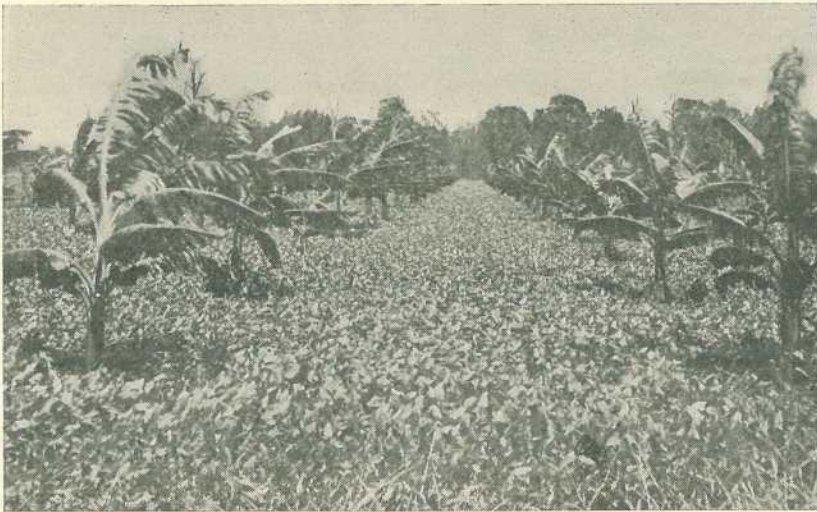

Plate 105.

A GREEN MANURE CROP AMONG LADY FINGER BANANAS AT PIMPAMA.

Bananas.

Banana growing on a commercial scale began on the South Coast in the 1920's, and a high level of production has been maintained ever since. Plantations are normally established on virgin rain forest and open forest soils. Under such conditions, the profitable life of the crop is about eight years, but if the plantation is properly managed this period can be extended a great deal. The essential features of good plantation management are soil conservation—principally contour planting and summer green manuring—fertilizer applications adequate to the needs of the crop, and rigorous control of the virus disease bunchy top. The importance of this disease is recognised by the special legislation in force to deal with it.

Bananas do well on a variety of soil types and each of the several commercial varieties has its own niche in the district. Grower preferences are dictated to some extent by aspect and altitude. The two most widely grown varieties are Mons Marie and the very similar,

if not identical, Williams Hybrid, both of which are semi-tall types capable of producing good quality fruit at higher altitudes than the dwarf Cavendish. The latter was formerly the main type cultivated and it is still an important commercial variety, although perhaps less tolerant of marginal soil and climatic conditions than some others. The Lady Finger is grown extensively on the better drained alluvial and heavy black clay loams near the coast in the northern part of the district. Owing to the incidence of Panama disease in this variety, growers show a tendency to make new plantings on slopes which would normally be assigned to other types.

The area of virgin land suitable for the crop is limited and the stability of the banana industry will depend on the ability of growers to prolong the life of the plantation or alternatively to recondition old banana land for replanting. Both present problems of soil management.



Plate 106.

HARVESTING PASSION FRUIT AT MUDGEERABA.

Passion Fruit.

Passion fruit grows well in some parts of the South Coast district, particularly on the plateau country, where cool weather brings the main crop to maturity at periods of the year when the principal markets are under-supplied with the fruit. Large-scale production occurs both on the rich, basaltic soils and on the coastal plains where good rains maintain a vigorous plant growth during most of the year. The seedlings are planted out during spring or autumn, preferably in well sheltered situations, and the vines are trained on wired trellises. The expense of establishing a crop is, therefore, high but this is compensated for by the high acreage returns. The initial crop appears within 12-15 months and the vines bear for at least four years if the plants are properly handled. The summer fruit crop matures rather late. Some of the passion vine diseases, particularly the virus disease woodiness and the fungous diseases brown spot and fusarium, may cause severe losses. Precautions are needed to keep these diseases in check and growers find it necessary to prune the vines and to spray regularly during the wetter months of the year.

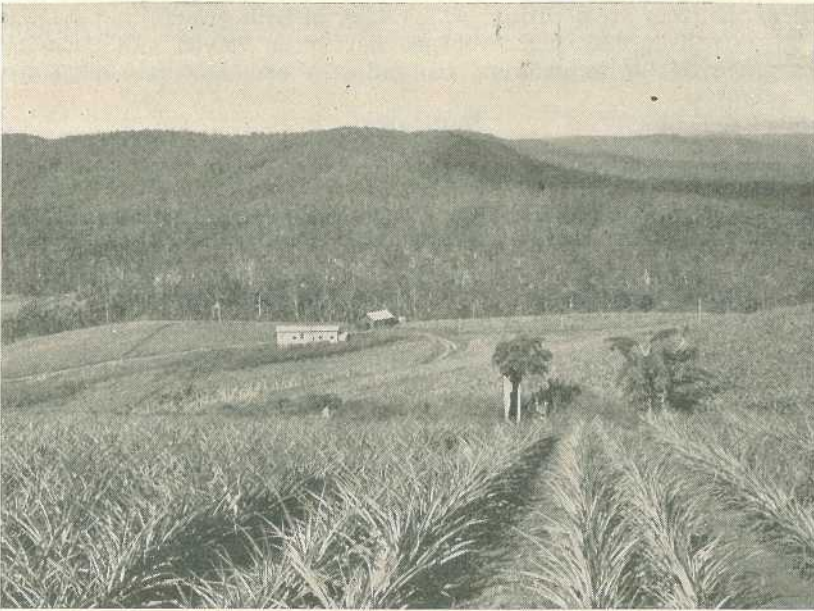

Plate 107.

A PINEAPPLE PLANTATION AT MOUNT NATHAN.

Pineapples.

The area under pineapples is limited, but there is room for expansion and future prospects are bright. Cultural methods which are already standardised in the main producing areas further north are equally applicable in the South Coast. Formerly small areas were planted in and near bananas, but other land specially selected for its free draining properties and its ability to produce high quality fruit is being used in recent commercial plantings. The rough leaved pine is grown for the local fresh fruit market but the smooth leaved Cayenne, which is required by canneries and the southern fresh fruit markets, must inevitably be the basis of future production.

Other Fruits.

A variety of other fruits is grown on a small scale in the district. Strawberries of the Queensland variety Phenomenal thrive on well-drained soils, some of which are red clay loams and other light grey sands. The crop is planted each year between late February and early March and harvesting begins in July. Most of the fruit is grown under contract for processing.

The papaw is a useful supplementary crop for planting on sheltered slopes and could be grown more extensively than at present. If seed beds are established in November and seedlings transplanted during February and March, fruit is borne within arm's reach for at least two years and harvesting is relatively easy.

Plantations of the Macadamia or Queensland nut, which is indigenous to the coastal scrubs of southern Queensland, are now in commercial production. The common "ternifolia" type, carrying leaves with the prickly edges, is well suited to the district because of its adaptability to a wide range of soils and its early maturing habit.

Most of the trees are seedlings which vary in both growth and cropping habits. Until propagation problems have been solved and "worked" trees are available to growers, the industry can, however, make little real progress.

Vegetables.

Although vegetables are not grown extensively on the South Coast, the types in steady demand are supplied to local markets by specialist growers with irrigation facilities. Their produce, together with that marketed from speculative plantings on non-irrigated farms, must be supplemented from metropolitan districts during those periods of the year when there is an influx of visitors to the coastal resorts.

Tomatoes are often planted on the warmer slopes during the winter and spring and good yields are obtained from irrigated crops. There is ample room for an extension of the area under winter crop, which is apt to set badly in some important market gardening districts during cool weather. The selection of sheltered, warm slopes for the crop pays dividends. French beans are grown all the year round in some part or other of the district. They do very well both as a field crop and as an inter-row crop in young banana plantations. The main variety is Brown Beauty, a small-seeded, high-quality bean which throws its pods well clear of the foliage and is consequently relatively easy to pick. The bulk of the production is in the northern part of the district.

Production.

Production records for the district are shown in Table 2.

TABLE 2.
HORTICULTURAL PRODUCTION—SOUTH COAST DISTRICT (1949).

FRUIT.			
	Total.	Bearing.	Production.
Bananas	2,163 acres	1,802 acres	142,486 1½-bus. cases
Pineapples	61 acres	41 acres	8,540 1½-bus. cases
Citrus	3,430 trees	895 trees	1,485 bus.
Nuts	2,784 trees	2,612 trees	14,871 lb.
Passion Fruit	23 acres	17 acres	4,295 ½-bus. cases
Mangoes	353 trees	199 trees	130 bus.
Papaws	9 acres	7 acres	1,197 bus.
Grapes	5 acres	4 acres	3,500 lb.
Strawberries	2 acres	..	2,595 lb.
Gustard Apples	48 trees	28 trees	10 bus.

VEGETABLES.		
	Acreage.	Production.
Green Peas	89	3,406 bus.
Tomatoes	37	8,650 ½-bus. cases
French Beans	25	1,919 bus.
Cucumbers	23	1,977 bus.
Cabbages	15	3,518 dozen
Melons—		
Water	13	43 tons
Rock	1	3 tons
Cauliflowers	7	595 dozen
Marrows and Squashes	6	27 tons
Turnips	5	17 tons
Lettuce	4	1,406 bus.
Carrots	3	8½ tons

MARKETING.

With the exception of bananas, and to a lesser extent pineapples, most South Coast horticultural produce is marketed locally. Exacting standards in harvesting and packing are, therefore, unnecessary, even for highly perishable commodities. Little improvement can be expected so long as small areas are speculatively planted with small fruits or vegetables to supplement a farm income drawn mainly from agricultural crops. More efficient methods of handling fruit and vegetables would be essential if growers were wholly dependent on horticultural crops.

In the case of bananas and pines, a premium can normally be expected for quality fruit placed on the market. Approximately 72,000 cases of bananas were consigned to New South Wales in 1948-49. For this market, efficient grading and packing are necessary to reduce wastage in transit. Some of the fruit grown near the border is railed from New South Wales terminals but most is transhipped at Clapham Junction to interstate trains. Local practice depends on the proximity of the grower to the nearest railhead. Considerable quantities of bunch and cased bananas are also marketed in Brisbane. The Lady Finger variety is invariably marketed in the bunch; other varieties may also be marketed in the bunch if road transport is available between the farm and the nearest market.

THE FUTURE.

The horticultural future of the South Coast, particularly the southern end of the district, depends on the stability of the most important crop, bananas. Payable markets and a standard of land and crop management much higher than that generally practised at the present time are necessary. Exploitative methods of growing bananas belong to the past now that little good virgin land is available. The industry will almost certainly maintain its present level and it may even expand to some extent. A group of efficient banana growers have weathered the sharp ups and downs of the industry during the past 30 years and their production returns show what can be done when the grower understands both his crop and his soil. The future depends very largely on their influence among new growers entering the industry.

The area under pineapples will expand if present price levels are maintained. One disability with this and some other crops is the distance between adjacent farms, which is such that growers have few opportunities to exchange views on their common problems. These contacts do much to improve production methods.

The northern end of the district is probably less subject to the speculative production of small crops than the southern end. Its geographical position, too, may induce a trend to vegetable production for the metropolitan market in the not too distant future, at least in areas where the soil is fertile and irrigation water is available to ensure continuity of production.

RENEW YOUR JOURNAL SUBSCRIPTION EARLY.

Journal subscribers are requested to renew their Journal subscriptions well in advance of the month of expiry, as it is often difficult to provide missing numbers.



Hints on Making Hives.

C. R. ROFF, Apiaries Inspector.

IN Queensland many beekeepers, both commercial and non-commercial, make their own hives. Due to the scarcity and increased cost of beekeeping equipment many others intend doing so and the following hints should be of interest.

When constructing a hive, the first essential is to decide the size and type. The Standard Langstroth ten-frame hive is the one most generally used in Queensland and home-made hives should conform to this general pattern. By having uniform equipment the parts are interchangeable from hive to hive and manipulation of the colonies is comparatively simple. An apiary composed of standard equipment will always sell at a better price than one made up of assorted or unusual sizes.

As the finished hive must be solidly built and able to withstand rough usage, the timber used should be seasoned softwood of good quality. The corners, which must remain square, are the weak parts of the hive and should be rabbeted and then nailed on both faces (Plate 108). Cement-coated nails should be used to prevent slipping, warping, and distortion. Before assembly, rabbeted surfaces should receive a good coat of oil paint.

The hive consists of a bottomboard, hive cover and hivebody or super containing ten movable frames. The component parts are not fastened together but are superimposed movable units (Plate 108).

The bottomboard or floor is 22 inches by 16 inches by $\frac{7}{8}$ inch thick. If an alighting board is not required the length should be reduced to 20 inches. On the upper surface, the edges should be raised on the two sides and the back end by nailing slats $\frac{7}{8}$ inch wide by $\frac{1}{4}$ inch thick. To prevent warping, two cleats 16 inches by 2 inches by $\frac{7}{8}$ inch thick should be attached across the under side of the bottomboard.

The top cover is designed to protect the hive from weather. A flush-fitting flat wooden cover, cleated on the upper side at the ends and across the centre, is the most convenient. The dimensions are 20 inches by 16 inches by $\frac{7}{8}$ inch thick. The cleats should be 16 inches by 2 inches by $\frac{7}{8}$ inch thick.

The hivebody or super is simply a bottomless wooden box which rests on the raised edges of the bottomboard. The standard dimensions of a hivebody or super made from $\frac{3}{8}$ inch timber are:—

Outside: 20 inches by 16 inches by $9\frac{1}{2}$ inches deep.

Inside: $18\frac{1}{4}$ inches by $14\frac{1}{4}$ inches by $9\frac{1}{2}$ inches deep.

If timber other than $\frac{3}{8}$ inch thick is used then all outside measurements of the hivebody, bottomboard and top cover will need to be adjusted. The inside dimensions as shown are essential for the correct fitting of the frames.

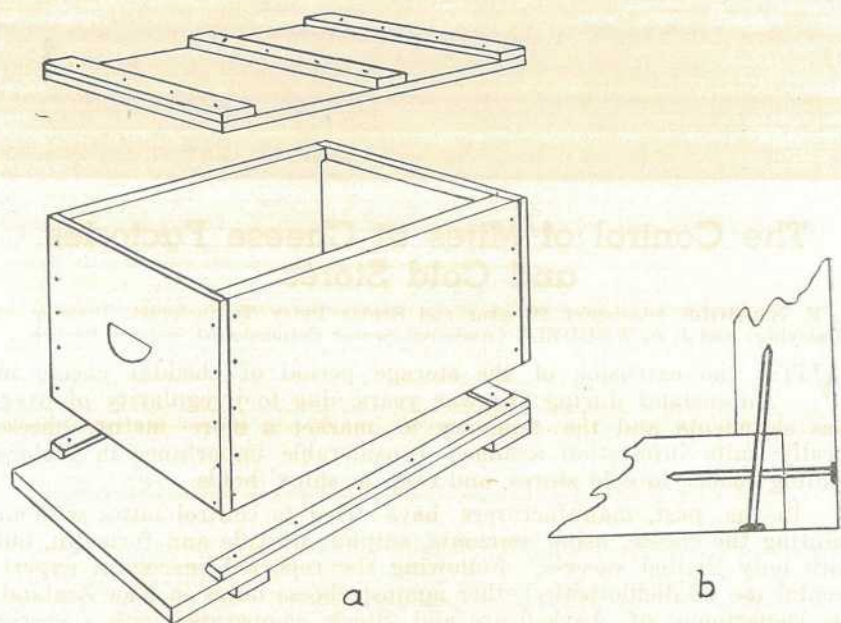

Plate 108.

DIAGRAM OF HIVE.—(a) Bottomboard, hivebody, and top cover; (b) corner of hive illustrating rabbeting and method of nailing.

The rabbets for cornering the hivebody should be cut into the end boards and should be $\frac{3}{8}$ inch wide by $\frac{7}{16}$ inch deep, to receive the ends of the sides. The length of the side timber will be 20 inches less the depth of the two $\frac{7}{16}$ inch rabbets, that is, $19\frac{1}{8}$ inches. Before the hivebody is assembled a rabbet, $\frac{7}{16}$ inch wide by $\frac{1}{2}$ inch deep, should be cut into the inner top edge of each end board for supporting the frames. If metal rabbets are to be fitted then the timber rabbet should be $\frac{3}{4}$ inch deep instead of $\frac{1}{2}$ inch. A shallow slot or finger-grip should be cut or chiselled into the face of each end board, slightly above centre.

After the hive has been completed two or three coats of paint should be applied externally, the sawn edges receiving particular attention. The paint weatherproofs the hive, which, if repainted about every two or three years, will last indefinitely. Furthermore, hive temperatures are lower if white or very light-coloured paints are used.

Home-made frames are not recommended as the factory machined frames are accurately constructed and usually cheaper. Self-spacing frames are the most useful.

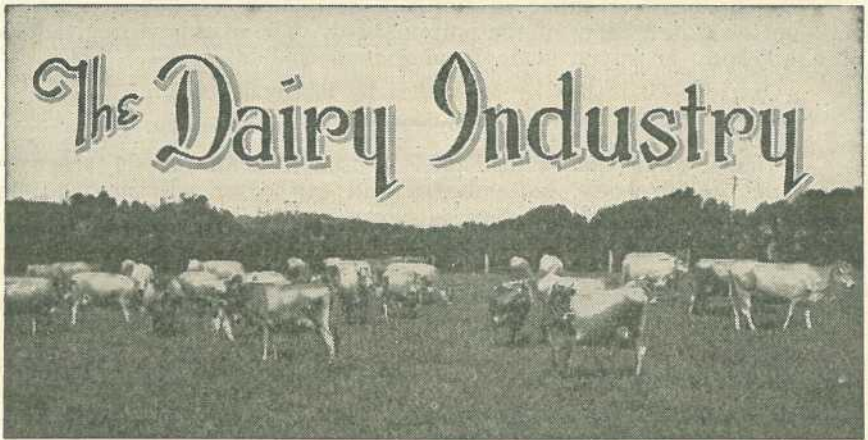

The Control of Mites at Cheese Factories and Cold Stores.

L. E. NICHOLS (Assistant Director and Senior Dairy Technologist, Division of Dairying) and J. A. WEDDELL (Assistant Senior Entomologist, Science Branch).

WITH the extension of the storage period of cheddar cheese in Queensland during the war years, due to irregularity of overseas shipments and the tendency to market a more mature cheese locally, mite infestation assumed considerable importance in factory holding rooms, in cold stores, and even in ships' holds.

In the past, manufacturers have tried to control mites without tainting the cheese, using ammonia, sulphur dioxide and formalin, but with only limited success. Following the reported successful experimental use of dichloroethyl-ether against cheese mites in New Zealand, the Department of Agriculture and Stock co-operated with a cheese manufacturing association and cold store owners in testing this material under commercial conditions in Queensland.

FACTORY TRIALS.

Two holding rooms containing waxed and unwaxed cheese were treated with dichloroethyl-ether. The cheeses were stored flat on wooden shelves and reasonably well spaced to permit of free circulation of the fumigant.

An atomising spray trigger gun with adjustable fine spray nozzle, known as an Engine Cleaning Gun, was fitted to the factory's compressed air system by means of 90 ft. of $\frac{3}{4}$ in. diameter pressure-tubing. A regulating valve and pressure gauge were attached to the end of the compressed air line, yielding 70 to 75 lb. per square inch pressure. Army gas masks No. 4 III, 1940 and 1941 models, fitted with $\frac{3}{4}$ in. diameter 5-ply steam rubber hose, which was later replaced by the standard cannisters, were worn by the operatives. The dosages were calculated on the basis of 1 lb. of dichloroethyl-ether per 1,000 cubic ft. of room space.

The atomised spray was so directed that all cheeses as well as empty shelves were enveloped in the spray mist. As far as possible marked wetting of cheese surfaces with the fumigant was avoided. Equipment used in the treatment is illustrated in Plate 109.

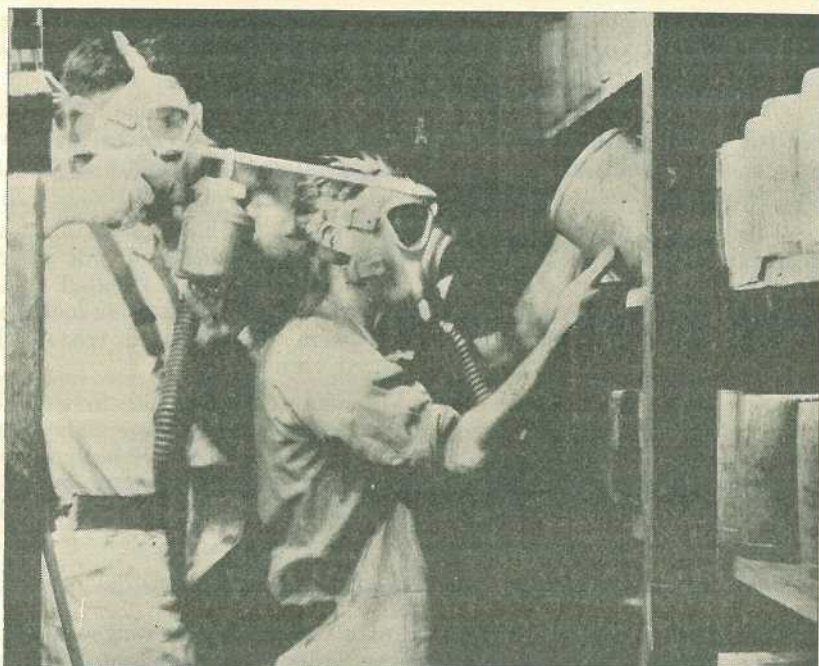

Plate 109.

EQUIPMENT USED IN HOLDING ROOM TRIALS.

In both cheese holding rooms subjected to treatment at the factory, heavy mite infestations occurred on the floors, shelving and the cheese. Loaf and medium sized cheese, including waxed and unwaxed, were stored in each room. The rooms were immediately sealed after treatment to prevent leakage of the fumigant and kept closed for a period varying from 24 to 48 hours before being opened and aired.

After airing, the cheese was transferred to treated shelves and turned so that the previously untreated surfaces were now exposed; a second dose at the rate of 1 lb. per 1,000 cu. ft. was applied and the rooms securely sealed for a further 48 hours. Some waxed and unwaxed cheese in the untreated rooms were conspicuously marked for future observation.

Because of the possible significance in the trade, and particularly for export purposes, various tests in crate treatment were made. For this purpose cheeses were stored in a third holding room that was heavily infested with mites and the various treatments included all combinations of waxed and unwaxed, treated and untreated cheeses, packed in treated and untreated crates. Observations on these cheeses were made over a period of two months.

Results.

(a) *Effect on Mite.*—Mite residues examined after the first treatment of the holding rooms showed a complete "kill" at all stages of the life cycle where directly exposed to the effects of the fumigant. However, there appeared to be no effect on the mite population under

the cheese, whether resting on the shelves or on other cheese or in cracked cheese. The surviving mite population, except in the cracked cheese, was, however, controlled by the second application.

(b) *Period of Immunity.*—Examination of the experimental cheese, after two months in the treated holding rooms, failed to reveal any live mites. However, continued observation indicated that a follow-up treatment was needed about three months after the first treatment.

With regard to the cheeses held in the infested holding room, those which had not been treated at all were noticeably infested, but where either the cheese or the crates or both had been treated with dichloroethyl-ether any mite infestation was of only a mild or localised nature. It was noted that untreated cheese was afforded reasonable protection simply by packing in a treated crate.

(c) *Effect on Cheese Flavour.*—Immediately after the first treatment, examination of plugs from waxed and unwaxed cheese showed no evidence of taint from the fumigant. The rind, however, of both waxed and unwaxed cheese had a distinct smell of dichloroethyl-ether, but this gradually diminished in intensity and after about three weeks could not be detected with any certainty.

COLD STORE TRIALS.

The success of the treatment with crated cheese suggested an extension of the trials with dichloroethyl-ether to the cold stores, where mites presented a problem in crated cheese for export. Methods of application that were tried included heat vaporisation of the fumigant buffered against explosion with carbon dioxide, spraying from a fixed spray line, and spraying from a hand atomiser.

The use of dichloroethyl-ether as a vapour was not persisted with owing to certain technical difficulties, including condensation in the specially arranged piping system. The fixed spray system did not favour uniform distribution of the fumigant due to the pressure gradient in the line, although in this case a large tonnage of cheese was treated with satisfactory results. It was therefore evident that the air-circulatory system had aided in the distribution. Finally, however, liquid application with a hand atomiser comparable to that in use at the factory was adopted.

Equipment and Method.

An engine spray gun with an adjustable spray nozzle and a one-quart capacity cannister was attached by means of 60 feet of $\frac{3}{8}$ -inch diameter pressure tubing to a mobile compressed air tank, filled by an electric air compressor. A pressure gauge and a regulating valve operating at 80 lb. per square inch were fitted. The general arrangement of this equipment is illustrated in Plate 110. All chamber outlets were carefully checked and sealed against possible gas leakage where considered necessary. Trays containing live mites were exposed in various parts of the cold store and at varying heights, some being protected and others unprotected from possible direct spray. This method of checking the effect of the fumigant on the mites had been used also for the fixed spray system.

The fumigant was applied as an atomised spray at the rate of 1 lb. per 1,000 cu. ft. as uniformly as possible over crates, walls and towards the ceiling. The cold store was then securely sealed for 48 hours.

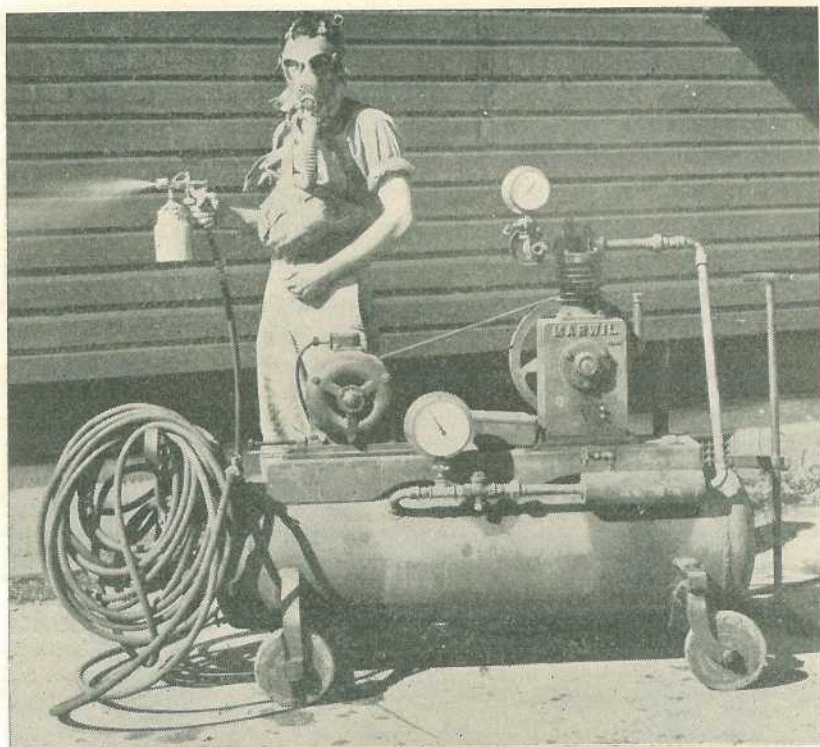

Plate 110.
EQUIPMENT USED IN COLD STORE TRIALS.

Results.

A complete kill of mites was obtained from the treatment, as was shown by examination of the sample trays and also of certain infested cheeses that had been earlier distributed in the chamber for test purposes. Both Commonwealth and State Graders confirmed that neither the cheese flavour nor the rind were affected by the treatment.

Treated Cheese Consigned to the United Kingdom.

The contents of the cold stores which had been treated were subsequently consigned in the one shipment to the United Kingdom. A qualified Commonwealth Officer examined this consignment in London and he reported a complete absence of mite infestation, and no effect whatsoever on the flavour or the rind of the cheese.

COSTS OF DICHLOROETHYL-ETHER TREATMENT AND OF SUITABLE ATOMISING EQUIPMENT.

The cost of the fumigant for treating 13,000 cu. ft. of room space at the cheese factory was £4 10s. 9d. As the weight of cheese treated was 23,000 lb., the cost averaged 0.04d. per lb. Dichloroethyl-ether is available locally for approximately 2s. per pound. The improvised equipment used at the cheese factory involved no special expenditure.

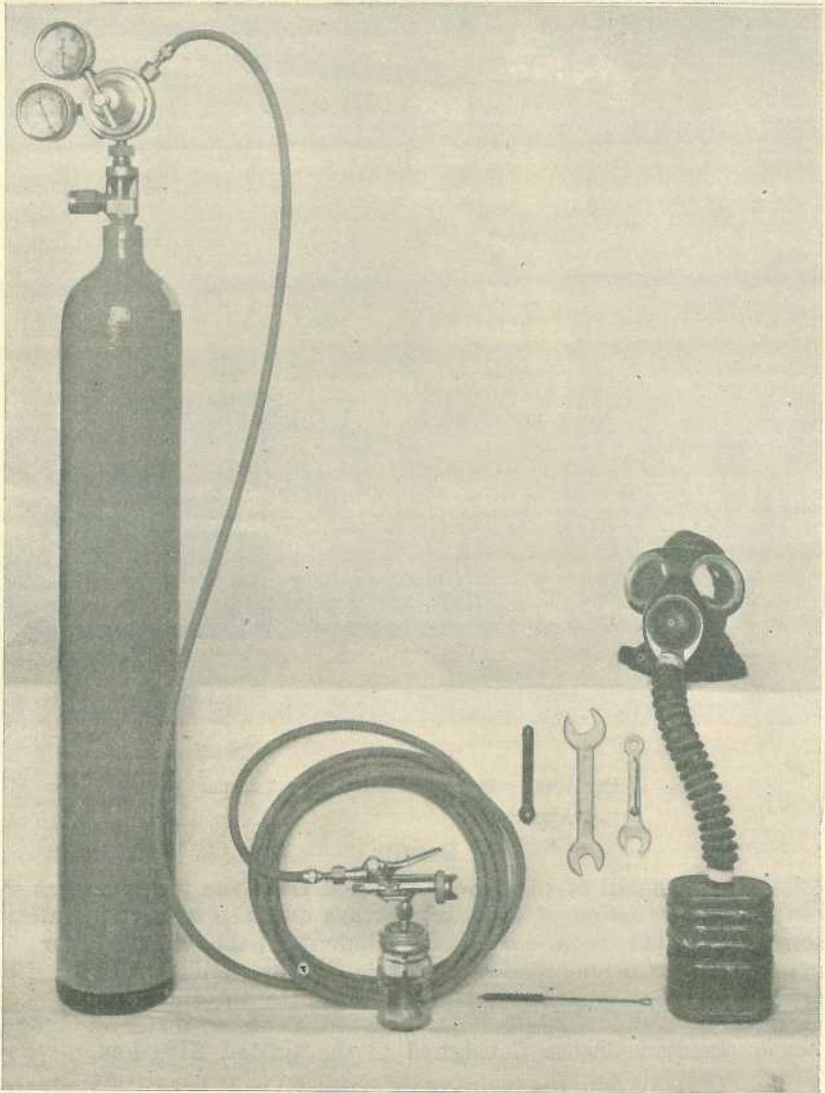

Plate 111.

PORTABLE OUTFIT FOR "ATOMISATION."

A complete portable outfit, including pressure tubing, adjustable spray gun, container and spanners (Plate 111) is now available on the local market for £15 10s. For each treatment a cylinder of compressed air is obtainable for 5s., the cylinders being returnable. This outfit is particularly suitable for small cheese factories where compressed air may not be available.

At the cold store the export consignment was treated at a cost of £5 2s., or 0.0006d. per lb., for chemicals only, the portable spray outfit and mobile pump being part of the cold store equipment and was operated by ordinary factory labour.

Further large scale treatments carried out by the employees at six cheese factories and four cold stores have proved the "atomisation" method to be cheap, practicable, and effective in controlling cheese mites.

CONCLUSIONS AND RECOMMENDATIONS.

The results indicated that a reasonable degree of control of mite infestation was obtained in cheese holding rooms and cold stores. For continued control, however, periodical treatments at approximately 3-monthly intervals appear essential, these treatments to be applied in conjunction with a reasonable standard of hygiene.

It is therefore recommended that the following treatments be applied according to the particular circumstances.

(a) Where cheese rooms are or can be emptied they should be thoroughly swept and cleaned, especially the shelving, and then sprayed with dichloroethyl-ether at the rate of 1 lb. of the fumigant per 1,000 cu. ft. The spray should be applied uniformly to all surfaces. A treated room should be immediately closed for a period of 24 hours.

(b) Where mite-infested cheese is already stored the following points should receive attention:—

(i.) The cheese should be spaced so as to permit of free circulation of the fumigant mist.

(ii.) Stocks should be rearranged so as to empty sections of the shelving or room.

(iii.) Dichloroethyl-ether should be uniformly sprayed throughout the room at the rate of 1 lb. per 1,000 cu. ft. and the room kept closed for a period of 24 hours.

(iv.) Following the first treatment the cheese should be inverted on to the previously emptied shelving.

(v.) The treatment should be immediately repeated.

(c) Where chutes or conveyors are used in transferring cheese to or from the chamber these also should be swept and sprayed.

(d) Where cheese is to be stored for a considerable period, particularly if stocks are being changed from time to time, treatments (b) and (c) above should be repeated every three months.

The above recommendations must be combined with a high standard of curing room hygiene, in that cheese should be frequently turned, cracked or otherwise damaged cheese removed, and shelving should be kept free of fat or grease accumulations by removal and scalding if necessary. In addition, temperatures in cheese store rooms should not exceed 60 degrees F.

In emergency cases, if mite-infested cheese is to be stored in otherwise clean rooms and fumigation is not immediately possible, such cheese and the crates or other containers may be lightly but thoroughly sprayed with dichloroethyl-ether. Uncrated cheese may be lightly brushed with the fumigant if an atomiser is not available. It is desirable that operators applying dichloroethyl-ether should be supplied with respirators comparable with the standard army pattern.



Wool and its Growth.

G. R. MOULE, Director of Sheep Husbandry.

THE wool follicle is often described as a minute factory in which wool is made. Accordingly, particular interest centres around its functioning and structure. It is not often appreciated, however, that Merino sheep, in common with most other breeds, have two quite different types of follicles. The proportion of different types determines the type of fleece any particular sheep will grow.

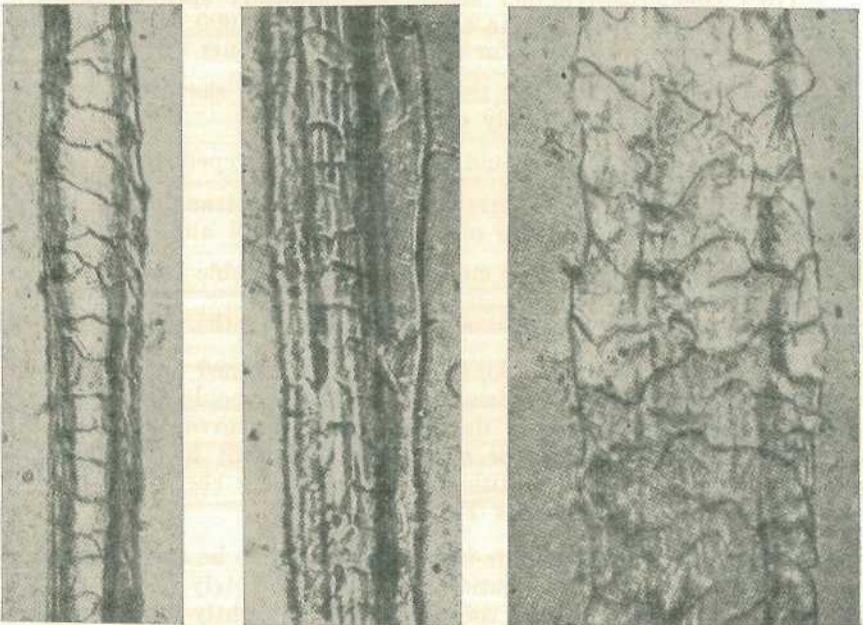

Plate 112.

MICROPHOTOGRAPHS OF FIBRES FROM VARIOUS BREEDS OF SHEEP.—*Left to right:* Tasmanian Merino, Southdown, Romney Marsh. (After A. F. Barker.)

Apart from the arrangement of the follicles, however, there are a number of factors which influence wool growth. These include such widely differing things as the way in which the sheep is fed, the weather conditions and the health of the animal. These are outlined in this article.

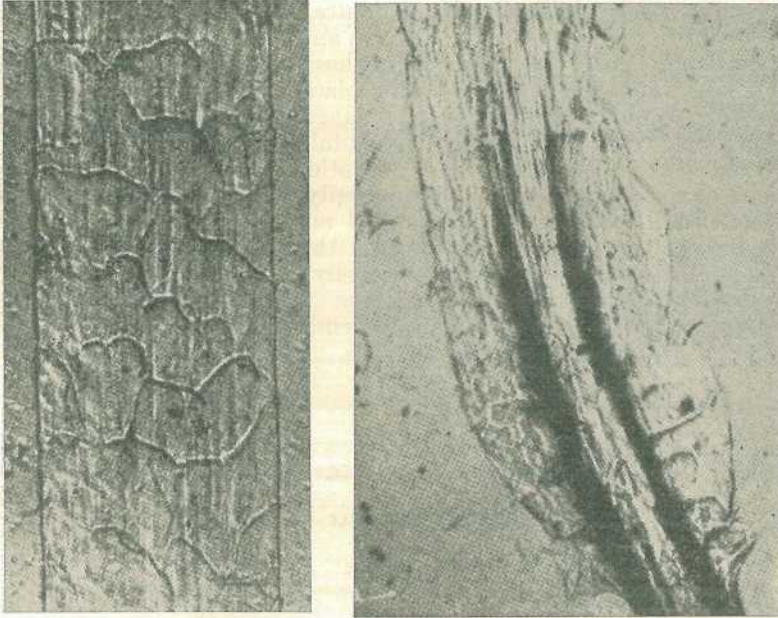

Plate 113.

COTSWOLD WOOL (LEFT) AND MOHAIR (RIGHT) FIBRES COMPARED.
(After A. F. Barker.)

Wool and Kemp Fibres.

There are many breeds of sheep and they are kept for such widely divergent purposes as wool-growing, dairy production and mutton raising. Naturally the appearance of the different breeds varies a good deal with the particular function the animals fulfil, but all sheep do not grow wool. Some breeds, such as the fat-tailed sheep indigenous to Africa, are covered by comparatively short, coarse fibres which resemble hair. Others, such as the Australian Merino and Corriedales, are noted for the wool they produce (Plates 112 and 113).

Rather an interesting story is told about some pigs which were left on an island in the Antarctic, probably in the early part of this century. When the weather station was established at Heard Island, the descendants of these animals were discovered. Instead of being covered with their usual coarse bristles they had grown a thick undercoat of soft fur which protected them from the cold.

In the development of the woolly coat of the Merino sheep similar physiological happenings probably occurred, although the animals were not subjected to such extreme variations in temperature. Wool is really the highly developed undercoat and even in a Merino fleece there are two kinds of fibres, referred to as primary and secondary fibres. The soft wool fibres are the secondary fibres, and the stiffer coarser kemps are the primaries.

The Structure and Development of the Wool Follicle.

The structure of a typical primary follicle and a secondary or wool growing follicle is shown in Plate 114. The most important differences lie in the absence of the arrector muscle and the sweat gland from the secondary follicle.

Despite their similarity in structure, there are important differences in the development of the follicles and it is worthwhile considering these in detail. After the ram's sperm has fertilised the ovum produced by the ewe rapid development takes place. It is not long before the developing lamb is covered with a layer of flat cells which do not present any very obvious developmental characteristics. Somewhere about the 30th to 45th day after conception these cells start to arrange themselves in definite order and gradually follicles are formed. These changes usually commence on the poll and the face and they spread down the midline of the back towards the tail. From the midline of the back they spread towards the belly and down the limbs. The average duration of this phase is about 15 days, so that by the time the foetus is 60 days old its skin covering is marked by quite a large number of rudimentary single follicles.

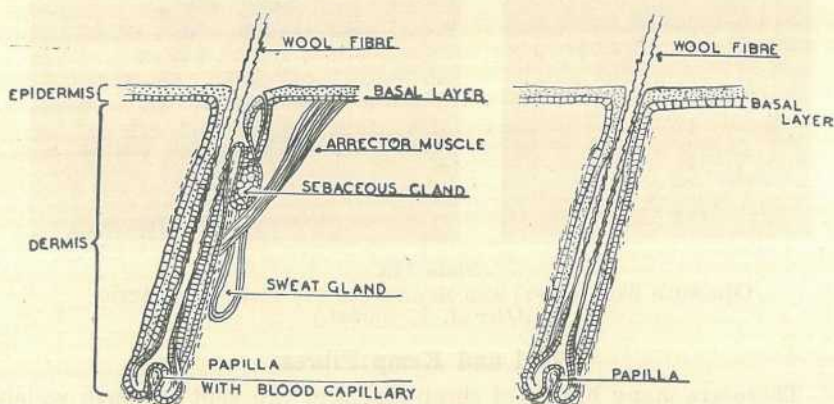

Plate 114.

STRUCTURE OF PRIMARY WOOL FOLLICLE (LEFT) AND SECONDARY WOOL FOLLICLE (RIGHT).

During the next stage additional small follicles develop on either side of the more advanced primaries. As this stage proceeds the follicles become arranged in groups of three and accordingly it is referred to as the trio stage and must be regarded as the real foundation of the follicle group. The arrangement of the follicles becomes progressively more orderly as they develop in short discontinuous parallel rows. This stage may commence about the 55th day after conception, though more usually it does not begin until the 75th day. As its duration is about 15 days it is complete by the 90th day.

During the next stage of development, which is referred to as the post-trio period, the secondary follicles make their first appearance between the members of the trio group. At this stage a race develops between the rate at which the skin grows and the rate at which the follicles and the connective tissue under the skin are laid down. Should the skin grow more quickly than the connective tissue beneath, the skin is thrown into a number of folds—that is, a “developed” lamb

is born. This final stage of development is the most important from the point of view of the density in terms of fibre populations per square inch. The density of the follicle population is greatest at about the 120th day after conception. Should the skin grow rapidly enough after that time to form itself into folds, the number of fibres per square inch of skin area decreases. If on the other hand the skin does not grow very extensively during the last 30 days before the lamb's birth, it fits the young body closely and there is little evidence of folds. In this case the wool follicles remain near their maximum density per unit of skin area.

At birth, then, the lamb has all the essential features for the arrangement of its adult fleece. Some secondary follicles may be added, but this soon stops. During the early growing period there may be expansion in the area occupied by the trio group of primary fibres and their associated secondary follicles due to an increase in the amount of skin tissue between them. There is a rapid emergence of the late secondary fibres. Finally there is successive shedding of the fibres from the primary follicles and this takes place approximately in the order of their establishment. While this shedding is a continuous process there is variation in the rate and the shed fibres are often replaced by stiff coarse "kemps." The development is shown diagrammatically in Plate 115.

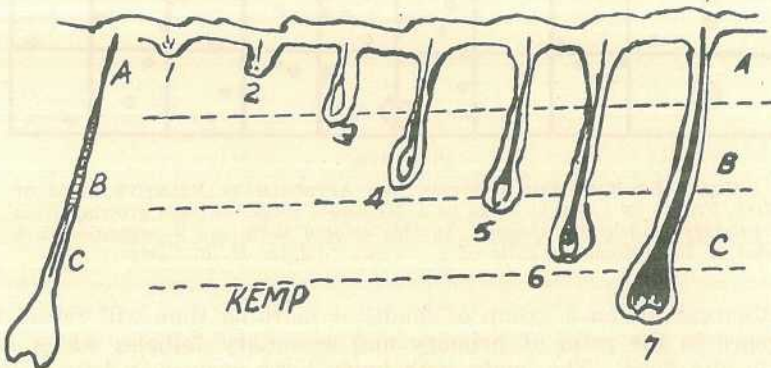

Plate 115.

DIAGRAM ILLUSTRATING THE CHANGE IN THE BIRTH COAT FIBRE FROM MERINO TO KEMP.—A, Merino Zone; B, Down Zone; C, Medullated Zone.

In view of these happenings the density of the fleece, in terms of the number of fibres per square inch, is only a relative term and it often decreases as the size of the animal's skin increases. Probably the most important factor is the relative proportion of the primary to secondary follicles, that is, the proportion of the total follicles which grow kemps and the proportion which grow wool fibres (Plates 116 and 117). It has been suggested that the relationship might be expressed by the formula $P:(P+S)$, where P is the total number of primary follicles per square inch and S the number of secondary follicles. For Merinos this ratio may vary between 1:15 and 1:28. For British breeds it is somewhat lower.

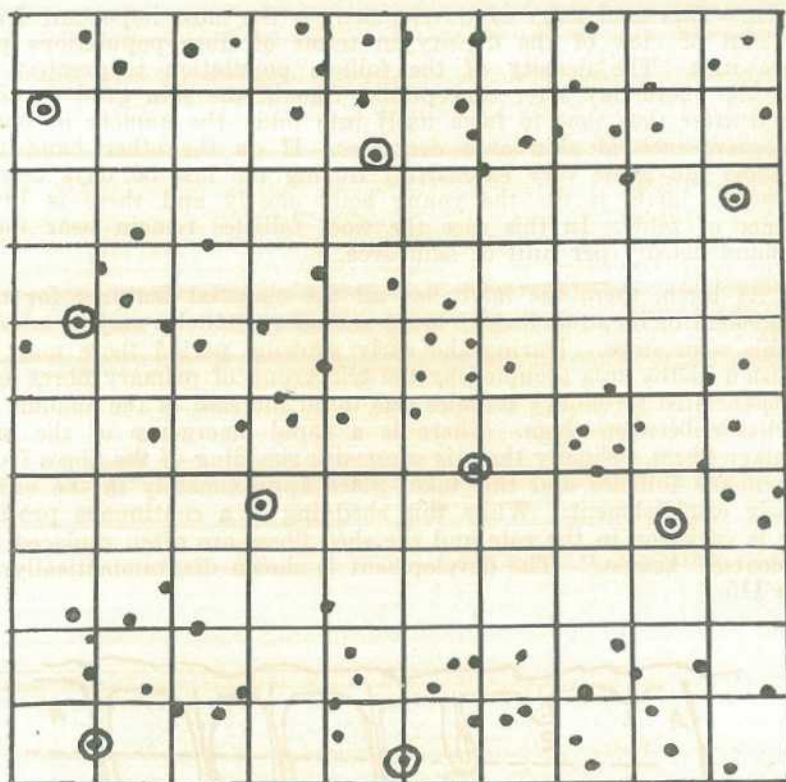

Plate 116.

CHART SHOWING THE POSITION AND APPROXIMATE RELATIVE SIZES OF WOOL FIBRES OF A SMALL AREA OF A MERINO'S SKIN.—Fibres growing from a primary follicle are ringed. In this section there are 9 primaries in a total of 103 follicles, a ratio of 1 : 11.45. (After H. B. Carter.)

Observations on a group of lambs at marking time will reveal the difference in the ratio of primary and secondary follicles which may exist in any flock. The lambs with hairy birth coats may have a high ratio of primary follicles or the emergence of the secondary fibres may have been delayed. On the other hand, the lamb with the soft woolly birth coat has a high proportion of functioning secondary follicles.

The definite gradation in the order in which these developmental changes take place leads to a fairly well known variation in the fleece of some sheep. While the breeder aims at keeping the covering of his animals as uniform as possible all over, weaknesses can often be noticed on the belly, the points and the breech. Poor covering of the belly and points suggests that a high proportion of secondary follicles have not developed in these parts. Hairiness of the breech suggests a higher proportion of primary follicles than is desirable.

Factors Influencing Wool Growth.

Many factors influence the growth of wool. They include those which act from within the sheep and those which are due to the external environment.

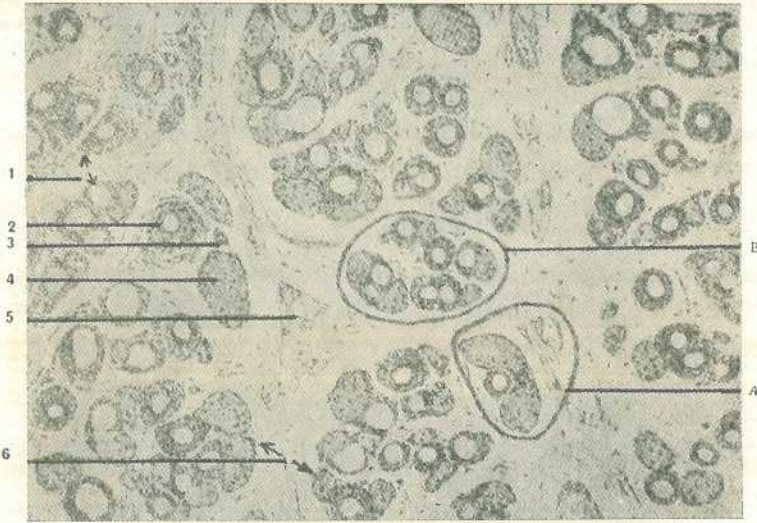

Plate 117.

SHOWING RELATIVE POSITIONS OF PRIMARY AND SECONDARY FOLLICLES IN A MERINO.—1. Minor or transverse connective tissue trabecula. 2. Wool follicle and fibre. 3. Sudoriferous gland duct. 4. Lobe of sebaceous gland. 5. *M. arrector pili*. 6. Major or longitudinal connective tissue trabecula.

A. *Primary follicle and accessory structures* (bilobar sebaceous gland, sudoriferous gland, and *m. arrector pili*).

B. *Secondary follicles*. Portion of a cluster occupying a characteristic position between two primary follicles.

(After H. B. Carter.)

Of those inherent in the sheep, breed, age and sex must be considered as well as the way in which the animal is fed and the efficiency with which it converts food to wool. Comparatively little need be said about the influence of breed. The wool grown by the British breeds is markedly different from Merino wool in staple length, crimp formation, colour, fibre diameter and the arrangement of the folds on the outer cuticle sheath (Plate 118). This is due to inherent differences in the arrangement and proportion of primary and secondary follicles, in the size of the lumen through which the wool is secreted and in the rate at which the wool is produced. These breed differences are obvious, but there are also strain differences within breeds. For instance, there are the fine woolled Tasmanian Merinos, the medium to strong woolled Peppins and the strong woolled South Australian Merinos, within the Merino population in this country. Even within strains there are differences between families and between individuals.

The age of the sheep affects wool growth by influencing the number of wool-growing follicles which are functioning. There is some evidence to suggest that some of the secondary follicles cease to function as the sheep gets older, although it is not clear if this is due directly to age or to other factors such as an impaired capacity of the sheep to handle its food because of worn teeth.



LUSTRE.

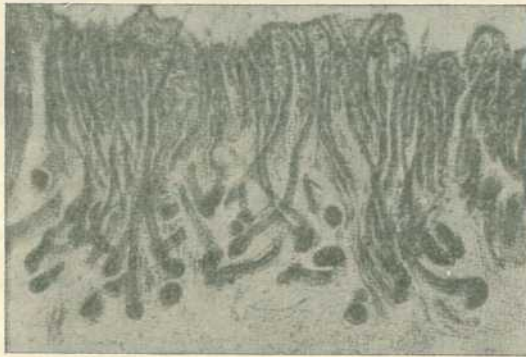

DOWN.



MERINO.

Plate 118.

SKIN SECTIONS OF LUSTRE (LINCOLN TYPE), DOWNS AND MERINO.
 (After A. F. Barker.)

After rain there is usually a quick flush growth which is followed by the setting of seed. Generally speaking, the available protein in the plant is concentrated in the seed, and unless a large number of these are available to the sheep, which is the case when they are living on clover burr, their diet may be protein deficient. A low protein content is characteristic of some of the pastures in western Queensland. This is

particularly the case in the Mitchell grass downs of the central-west and north-west, where summer rainfall predominates. Acute protein deficiency is seen in drought time when there is an overall shortage of food, but there is an imperceptible protein deficiency in the spring of quite good years. In the southern part of the State, winter and early spring rains are more reliable and there are a large number of herbage plants which ensure a more even supply of protein in the diet.

Of the environmental factors influencing the growth of wool, nutrition is of paramount importance. Wool is largely composed of protein and an adequate and even supply in the diet is a necessary precursor to normal wool growth. Most feeding standards suggest that adult sheep require 1.75 lb. of digestible crude protein per week to meet the normal requirements for maintenance and for wool growth. From results obtained in hand feeding of stud Merino sheep, it appears that this may not be adequate to allow for maximum wool production. Probably 2.25 lb. of digestible crude protein is nearer to the actual requirements.

The building blocks of which proteins are made are known as amino acids and some of these are essential for the growth of wool. Two of the most important amino acids are cystine and methionine and there are quite wide variations in the quantity different plants contain. The reputation which linseed meal has won as a sheep feed is partly due to its amino acid content.

During times of protein shortage the sheep decreases the amount of wool keratin which is secreted from the follicles. There are three ways in which this can be done:

- (1) It may decrease the rate of wool growth; this leads to a decrease in staple length.
- (2) It may decrease the size of the aperture of each follicle; this leads to a decrease in fibre diameter.
- (3) It may decrease the number of follicles which are functioning; this leads to a decrease in density of the fleece.

Probably the sheep uses a combination of these and does not rely on any particular one. In times of acute stress, such as occurs during sickness, flystrike or a very bad drought, the sheep usually decreases the diameter of its fibres fairly rapidly and this may lead to a "break" in the wool.

There may also be a decrease in density as the sheep grows older, as it is probable that some secondary follicles cease to function in some aged animals. This may be an explanation of the so-called "doggy" wool in some old sheep.

It is now well known that copper is an essential constituent in the diet of sheep. Besides affecting the rate of blood production it is essential to the formation of a normal crimp. Usually the soft pliable substances from which wool is formed are converted into keratin in the lower part of the follicle. When there is inadequate copper circulating in the blood the formation of wool keratin is delayed and is completed only just before the fibre emerges from the follicle. This leads to the formation of the abnormal wavy crimp so characteristic of copper deficiency (Plates 119 and 120).

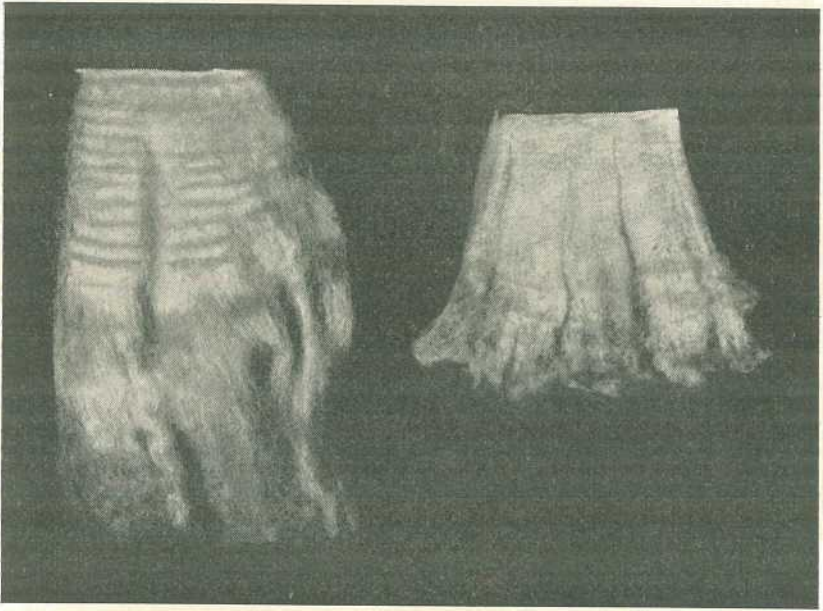

Plate 119.

EFFECT OF COPPER DEFICIENCY ON WOOL.—*Left*, Crossbred wool, showing half of staple copper deficient. *Right*, Merino wool, showing last inch of staple copper deficient.

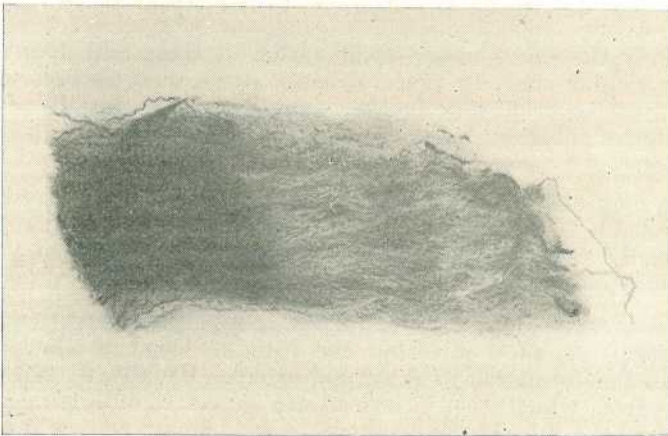

Plate 120.

EFFECT OF COPPER DEFICIENCY ON WOOL.—This sample taken from a black sheep shows how the wool became pale and lost its crimp when the sheep was put on a diet deficient in copper.

MARKETING

"The Pest Destroyers Act of 1939"— Registrations.

A PEST destroyer is any prepared or natural substance sold as a fungicide, insecticide, vermin destroyer, weed destroyer, lure or steriliser or cleanser.

A fungicide is any substance used or intended to be used for the purpose of destroying or preventing the attacks of fungi or other parasitic plants or bacteria affecting or which may affect seeds, fruit, vegetables, plants, or other produce of the soil or any stock food, or any substance declared by regulation to be a fungicide.

An insecticide is any substance used or intended to be used for the purpose of destroying insects or other pests which infest or attack seeds, fruit, vegetables, plants, or other produce of the soil, or any stock food or which infest or attack animals, or for preventing such insects or pests from infesting or attacking the same, or any substance declared by regulation to be an insecticide.

A vermin destroyer is any substance used or intended to be used for the purpose of destroying rabbits, rodents, dingoes, foxes, or other noxious animals or noxious birds, or any substance declared by regulation to be a vermin destroyer.

A weed destroyer is any substance used or intended to be used for the purpose of destroying or preventing the spread of weeds or noxious plants, or any substance declared by regulation to be a weed destroyer.

A lure is any material used or intended to be used to lure or attract any insect or pest or vermin for purposes of destruction.

A steriliser or cleanser is any substance used or intended to be used, or advocated for use, for the purpose of sterilising or cleansing dairy utensils, equipment, or machinery, or used or intended to be used for any other sterilising or cleansing purpose relating to agriculture or stock: Provided that soaps and soap powders that do not contain any constituents useful or claimed to be useful for sterilising shall not be included.

Before any pest destroyer is placed upon the Queensland market, an application for registration must be made by the Queensland primary dealer and such application renewed every three years, i.e.,

1952, 1955, 1958, &c., during the month of January. Registration fees are payable annually. No sales should take place until registration has been effected.

Application for registration or renewal thereof involves the forwarding of a statutory declaration, setting out the formula of the preparation, accompanied by a specimen label and sample, and the necessary fees, i.e., 5s. for each preparation, with a maximum of £1 per year. These applications are duly examined with respect to the Act's requirements and placed before the Pest Destroyers Board—consisting of the Agricultural Chemist, an entomologist (plants), an entomologist (veterinary), a pathologist (plants), a pathologist (veterinary), and the Registrar.

The formulae, claims and statements made are considered, and, if approved, the pest destroyer, upon completion of all the Act's requirements, is duly registered.

All labels are required to set out the following:—

(a) The distinctive name of the pest destroyer;

(b)—

(i.) A statement of the names and respective percentages of the active constituents with the forms in which they occur or substances from which they are derived;

(ii.) A statement of any prescribed particulars relative to standard, quality, or rate of dilution with respect to the pest destroyer concerned;

(c) The net weight or volume content of the package;

(d) All directions for use of the pest destroyer;

(e) The name and address of the primary dealer or manufacturer;

(f) The word POISON when required.

The word "POISON" should be in red letters on a white ground, in larger and heavier type than any other letter on the label; and no other word shall appear on the same line. No other letter on the label shall be in a red colour.

Farmers and other buyers would be well advised *never to accept delivery* of any pest destroyer unless it has affixed to the package a plainly printed label setting out the required information.

In the absence of a label it is obvious that the buyer should at once communicate with the Standards Branch, Department of Agriculture and Stock, William Street, Brisbane.

The Pest Destroyers Act provides that no person shall affix any label and/or brand to or issue or use with or in connection with any pest destroyer or the sale thereof, any invoice, directions for use, or any printed, typed or written matter, and/or advertisement which contains—

(a) Any statement which is false or misleading in any particular concerning the substances therein referred to;

- (b) Any comment or reference to or explanation of any statement required by this Act which directly or by implication contradicts, qualifies, or modifies any particular required by this Act to be shown thereon;
- (c) Any statement, comment, or reference which expresses, suggests, or implies, or may be construed to express, suggest, or imply, that the pest destroyer has been the subject of a trial or trials or has been used or is recommended by the Department of Agriculture and Stock and which could in any way be used for purposes of furthering the sale of such pest destroyer;
- (d) Any words or expression signifying, suggesting, or implying that the pest destroyer is approved or guaranteed under the provisions of this Act or any other Queensland law.

The pest destroyers as set out in the following list are those that have been registered up to 2nd December, 1949, for the three-year period January, 1949, to December, 1951, under the above Act. These and any published in subsequent lists are the only pest destroyers that should be offered for sale or requested by prospective purchasers.

It should be noted that the sale of any unregistered pest destroyer would render the seller liable to a penalty not exceeding £50.

Further particulars may be obtained from the Standards Branch, Department of Agriculture and Stock, William Street, Brisbane.

LIST OF PEST DESTROYERS REGISTERED IN QUEENSLAND UNDER "THE PEST DESTROYERS ACT OF 1939."
For the Period Commencing January, 1949, as at 2nd December, 1949.

Name of Pest Destroyer.	Active Constituents as Declared by Seller.		Queensland Wholesale Dealer.
ARSENATE OF LEAD.			
POWDER.			
	Per cent.		
A.C.F. Arsenate of Lead Powder	31.0	Arsenic Pentoxide (As ₂ O ₅) as Lead Arsenate	A.C.F. & Shirleys Fertilizers Ltd., Little Roma street, Brisbane
Lane's Arsenate of Lead	31.0	Arsenic Pentoxide (As ₂ O ₅)	A. G. Bignold & Co., 169 Elizabeth street, Brisbane
Pinnacle Brand Arsenate of Lead	30.5	Arsenic Pentoxide (As ₂ O ₅) as Lead Arsenate	Cloudust Spray Manufacturers, Montague road, South Brisbane
Waratah Brand Arsenate of Lead	30.5	Arsenic Pentoxide (As ₂ O ₅) as Lead Arsenate	Committee of Direction of Fruit Marketing, Turbot street, Brisbane
"Vallo" Arsenate of Lead Powder	32.0	Arsenic Pentoxide (As ₂ O ₅)	A. Victor Leggo & Co. Pty. Ltd., 185 Mary street, Brisbane
Berger's Mercury Brand Arsenate of Lead Powder	31.0	Arsenic Pentoxide (As ₂ O ₅) as Lead Arsenate	Neptune Oil Co. Pty. Ltd., 301-7 Ann street, Brisbane
Cooper's Arsenette	31.0	Arsenic Pentoxide (As ₂ O ₅)	Queensland Fruitgrowers' Co-op. Soc. Ltd., Makerston street, Brisbane
PASTE.			
"Vallo" Arsenate of Lead Paste	32.0	Arsenic Pentoxide (As ₂ O ₅) (on dry basis)	A. Victor Leggo & Co. Pty. Ltd., 185 Mary street, Brisbane
Berger's Mercury Brand Arsenate of Lead (Paste)	30.0	Arsenic Pentoxide (As ₂ O ₅) (on dry basis)	Neptune Oil Co. Pty. Ltd., 301-7 Ann street, Brisbane
ARSENATES OF CALCIUM.			
"Vallo" Arsenate of Calcium	40.0	Arsenic Pentoxide (As ₂ O ₅)	A. Victor Leggo & Co. Pty. Ltd., 185 Mary street, Brisbane
ARSENATE OF SODA.			
Elliott's Tinbar	64.0	Arsenic Trioxide (As ₂ O ₃)	Taylor's Elliotts Pty. Ltd., 150-160 Charlotte street, Brisbane
ARSENIC.			
Refined Arsenic	99.0	Arsenic Trioxide (As ₂ O ₃)	G. Horsburgh & Co. Pty. Ltd., Kent street, Maryborough
"Vallo" White Arsenic	98.0	Arsenic Trioxide (As ₂ O ₃)	A. Victor Leggo & Co. Pty. Ltd., 185 Mary street, Brisbane
Street's Pure Arsenic	98.0	Arsenic Trioxide (As ₂ O ₃)	Wm. Street & Sons, 176 Ann street, Brisbane
ARSENIC PENTOXIDE.			
"Vallo" Granulated Pentoxide Weed Killer	83.0	Arsenic Pentoxide (As ₂ O ₅)	A. Victor Leggo & Co. Pty. Ltd., 185 Mary street, Brisbane
Elliott's Voskin	60.6	Arsenic (As ₄) as Arsenic Pentoxide	Taylor's Elliotts Pty. Ltd., 150 Charlotte street, Brisbane
ARSENICAL WEED AND VERMIN DESTROYERS.			
Bickford's Ant Powder	35.0	Arsenic Trioxide (As ₂ O ₃)	A. M. Bickford & Sons Ltd., Tank street, Brisbane
Nosco Liquid Weed Killer	36.0	Arsenic Trioxide (As ₂ O ₃) as Sodium Arsenite	A. G. Bignold & Co., 169 Elizabeth street, Brisbane
Knoxit Liquid Weed Killer	54.0	Arsenic Trioxide (As ₂ O ₃)	Cloudust Spray Manufacturers, Montague road, South Brisbane
C.O.D. Improved Weed Killer	40.0	Arsenic Trioxide (As ₂ O ₃)	Committee of Direction of Fruit Marketing, Turbot street, Brisbane
Ex-L-Col Tree Killer	64.0	Arsenic Trioxide (As ₂ O ₃)	Denham Bros. (R'ton) Pty. Ltd., East street, Rockhampton
Quickstroy Improved Weed Killer	40.0	Arsenic Trioxide (As ₂ O ₃)	J. H. Eden & Co., 483 Lutwyche road, Lutwyche, Brisbane
Harton Weed Killer	64.0	Arsenic Trioxide (As ₂ O ₃)	Goldsbrough Mort & Co. Ltd., Eagle street, Brisbane
Graydust	30.0	Sodium Fluoride	Houghton & Byrne Pty. Ltd., 161 Queen street, Brisbane
	50.0	Arsenic Trioxide (As ₂ O ₃)	
Camella Weed Killer	36.0	Arsenic Trioxide (As ₂ O ₃)	International Traders, 228 Roma street, Brisbane
Arzeen Liquid	86.4	Arsenic Trioxide (As ₂ O ₃)	A. Victor Leggo & Co. Pty. Ltd., 185 Mary street, Brisbane
Mactaggart's Tree Killer	64.0	Arsenic Trioxide (As ₂ O ₃)	Mactaggart's P.P. Co-op. Assn. Ltd., 70-2 Eagle street, Brisbane
Mactaggart's Weed, Scrub and Tree Killer	36.0	Arsenic Trioxide (As ₂ O ₃)	Mactaggart's P.P. Co-op. Assn. Ltd., 70-2 Eagle street, Brisbane
P.C.D. Tree Killer	64.0	Arsenic Trioxide (As ₂ O ₃)	Port Curtis Co-op. Dairy Assn. Ltd., O'Connell street, Gladstone
Cooper's Weedicide	56.0	Arsenic Trioxide (As ₂ O ₃)	Queensland Fruitgrowers' Co-op. Soc. Ltd., Makerston street, Brisbane

Hart's Liquid Arsenic	85-0	Arsenic Trioxide (As ₂ O ₃)	Queensland Pastoral Supplies Pty. Ltd., Bowen street, Brisbane
Killaweed (in two solutions)	80-0	Arsenic Trioxide (As ₂ O ₃) (in one solution)	Queensland Pastoral Supplies Pty. Ltd., Bowen street, Brisbane
Street's Cure for Ants, etc.	5-5	Arsenic Trioxide (As ₂ O ₃) as Sodium Arsenite	Wm. Street & Son, 176 Ann street, Brisbane
Street's Cure for Weeds, etc.	10-0	Arsenic Trioxide (As ₂ O ₃) as Sodium Arsenite	Wm. Street & Son, 176 Ann street, Brisbane
Tropic Tree Killer	64-0	Arsenic Trioxide (As ₂ O ₃)	Tropical Dip & Chemical Co., Cambridge street, Rockhampton
United Improved Weedtox	64-0	Arsenic Trioxide (As ₂ O ₃)	United Chemicals Pty. Ltd., 91-7 Montague road, South Brisbane
United Liquid Tree Killer	64-0	Arsenic Trioxide (As ₂ O ₃)	United Chemicals Pty. Ltd., 91-7 Montague road, South Brisbane

BENZENE HEXACHLORIDE PREPARATIONS.

Aeroflo CSG 7602 Dust	7-0	Copper (Cu) as Copper Oxychloride	Aeroflo Dusts & Sprays Pty., Redland Bay Road, Redland Bay
	60-0	Sulphur (S) as Powdered Sulphur	
Aeroflo G. 5 Dust	0-26	gamma isomer of Benzene Hexachloride	Aeroflo Dusts & Sprays Pty., Redland Bay Road, Redland Bay
F.D.L. BHC 10 % Dust	0-5	gamma isomer of Benzene Hexachloride	
Gammawash	1-3	gamma isomer of Benzene Hexachloride	Fertiliser Distributors Pty. Ltd., Little Roma street, Brisbane
Gammexane Industrial Dust No. 1	3-5	gamma isomer of Benzene Hexachloride	Grazcos Co-op. Ltd., 356 Queen street, Brisbane
Gammexane 50 Dispersible Powder	0-5	gamma isomer of Benzene Hexachloride	Imperial Chemical Industries of Aust. & N.Z. Ltd., 293 Queen street, Brisbane
Gammexane Liquid Concentrate LG. 140	6-5	gamma isomer of Benzene Hexachloride	Imperial Chemical Industries of Aust. & N.Z. Ltd., 293 Queen street, Brisbane
Gammexane No. 7 Miscible Oil	10-0	gamma isomer of Benzene Hexachloride	Imperial Chemical Industries of Aust. & N.Z. Ltd., 293 Queen street, Brisbane
Gammexane No. 10 Dust	7-0	gamma isomer of Benzene Hexachloride	Imperial Chemical Industries of Aust. & N.Z. Ltd., 293 Queen street, Brisbane
Gammexane Smoke Generator No. 2	1-3	gamma isomer of Benzene Hexachloride	Imperial Chemical Industries of Aust. & N.Z. Ltd., 293 Queen street, Brisbane
Gammexane Smoke Generator No. 12	3-25	gamma isomer of Benzene Hexachloride	Imperial Chemical Industries of Aust. & N.Z. Ltd., 293 Queen street, Brisbane
Gammexane Smoke Generator No. 22	3-25	gamma isomer of Benzene Hexachloride	Imperial Chemical Industries of Aust. & N.Z. Ltd., 293 Queen street, Brisbane
Cooper's Louse Powder	14-4	gamma isomer of Benzene Hexachloride	Imperial Chemical Industries of Aust. & N.Z. Ltd., 293 Queen street, Brisbane
Ganna Di	0-6	gamma isomer of Benzene Hexachloride	New Zealand Loan & Mercantile Agency Co. Ltd., Eagle street, Brisbane
Cooper's Gamaturf	1-3	gamma isomer of Benzene Hexachloride	Nightingale Supply Co. Ltd., 1078 Ann street, Brisbane
Plane Brand Gammacide No. 5 Dust	6-0	gamma isomer of Benzene Hexachloride	Qld. Fruitgrowers Co-op. Soc. Ltd., Makerston street, Brisbane
Rudust No. 13 10% BHC in Rock Phosphate	0-5	gamma isomer of Benzene Hexachloride	Qld. Fruitgrowers Co-op. Soc. Ltd., Makerston street, Brisbane
Rudust No. 14 10% BHC in China Clay	1-3	gamma isomer of Benzene Hexachloride	Taubmans Qld. Pty. Ltd., 95 Edward street, Brisbane
	1-3	gamma isomer of Benzene Hexachloride	Taubmans Qld. Pty. Ltd., 95 Edward street, Brisbane

BISULPHIDE OF CARBON.

I.C.I.A.N.Z. Carbon Bisulphide	90-0	Carbon Bisulphide	Imperial Chemical Industries of Aust. & N.Z. Ltd., 293 Queen street, Brisbane
--	------	---------------------------	---

BORDEAUX MIXTURE (COPPER LIME).

Lane's Bordo Powder	12-5	Copper (Cu) as Copper Oxychloride	A.G. Bignold & Co., 169 Elizabeth street, Brisbane
-----------------------------	------	---	--

CATTLE DIP CONCENTRATES.

ARSENICAL LIQUID.			
(a) Dilution less than 1 in 200—			
Non-Ox Liquid Cattle Dip	32-0	Arsenic Trioxide (As ₂ O ₃)	Australian Chemical Co. Pty. Ltd., 305 Montague road, South Brisbane
	4-5	Cresylic Acid (dilution 1 in 160)	
Australian Liquid Dip	32-0	Arsenic Trioxide (As ₂ O ₃)	H. Blaiklock & Co. Pty. Ltd., 150 Mary street, Brisbane
	4-5	Phenols and Cresols (dilution 1 in 160)	
Queensland Cattle Dip (Homogeneous)	32-0	Arsenic Trioxide (As ₂ O ₃)	Dalgety & Co. Ltd., Elizabeth street, Brisbane
	12-0	Cresols (dilution 1 in 160)	
Royal Cattle Dip (Homogeneous)	32-0	Arsenic Trioxide (As ₂ O ₃)	Dalgety & Co. Ltd., Elizabeth street, Brisbane
	12-0	Cresols (dilution 1 in 160)	
Tickstroy Cattle Dip	32-0	Arsenic Trioxide (As ₂ O ₃) (dilution 1 in 160)	J. H. Eden & Co., 283 Lutwyche road, Lutwyche, Brisbane
Kiltic Liquid Cattle Dip	32-0	Arsenic Trioxide (As ₂ O ₃) (dilution 1 in 160)	
Mactaggarts' Improved Liquid Cattle Dip	32-0	Arsenic Trioxide (As ₂ O ₃)	G. Horsburgh & Co. Pty. Ltd., 320 Kent street, Maryborough
	4-5	Phenols and Cresols (dilution 1 in 160)	
Cooper's Improved Cattle Dip	20-0	Arsenic Trioxide (As ₂ O ₃) (dilution 1 in 125)	Mactaggarts P.P. Co-op. Assn., Ltd., Eagle street, Brisbane
	32-0	Arsenic Trioxide (As ₂ O ₃)	
Sidolia Liquid Cattle Dip	4-5	Cresylic Acid (dilution 1 in 160)	New Zealand Loan & Mercantile Agency Co. Ltd., Eagle street, Brisbane
	32-0	Arsenic Trioxide (As ₂ O ₃) (dilution 1 in 160)	
Standard Liquid Cattle Dip 1-160	32-0	Arsenic Trioxide (As ₂ O ₃) (dilution 1 in 160)	Norris Agencies Pty. Ltd., 639 Ann street, Brisbane
Kiltic Liquid Cattle Dip	32-0	Arsenic Trioxide (As ₂ O ₃) (dilution 1 in 160)	
United Cattle Dip	32-0	Arsenic Trioxide (As ₂ O ₃) (dilution 1 in 160)	Queensland Chemical & Distributing Co., 107 Eagle street, Brisbane
Little's Cattle Dip	23-0	Arsenic Trioxide (As ₂ O ₃) w/w (dilution 1 in 160)	
"Apollo" Cattle Dip Single Strength	32-0	Arsenic Trioxide (As ₂ O ₃) (dilution 1 in 160)	Surgical Supplies Ltd., 428 Queen street, Brisbane
			United Chemicals Pty. Ltd., 91-7 Montague road, South Brisbane
			Wilcox, Moffin Ltd., Albert street, Brisbane
			Winchcombe, Carson Ltd., 99 Eagle street, Brisbane

LIST OF PEST DESTROYERS REGISTERED IN QUEENSLAND UNDER "THE PEST DESTROYERS ACT OF 1939."—*continued.*

For the Period Commencing January, 1949, as at 2nd December, 1949.

Name of Pest Destroyer.	Active Constituents as Declared by Seller.	Queensland Wholesale Dealer.
CATTLE DIP CONCENTRATES—<i>continued.</i>		
ARSENICAL—LIQUID—<i>continued.</i>		
<i>(b) Dilution 1 in 300 and over—</i>		
"Acco" 1-300 Liquid Cattle Dip ..	60-0 Arsenic Trioxide (As ₂ O ₃) 9-5 Cresylic Acid (dilution 1 in 300)	Australian Chemical Co. Pty., Ltd., 305 Montague road, South Brisbane
Australian Double Strength Liquid Dip	64-0 Arsenic Trioxide (As ₂ O ₃) 10-0 Cresols and Phenols (dilution 1 in 320)	H. Blaiklock & Co. Pty. Ltd., 150 Mary street, Brisbane
Royal Cattle Dip (Concentrated)	35-0 Arsenic Trioxide (As ₂ O ₃) w/w (dilution 1 in 300)	Dalgety & Co. Ltd., Elizabeth street, Brisbane
Ex-L-Col 1-320 Liquid Cattle Dip	64-0 Arsenic Trioxide (As ₂ O ₃) (dilution 1 in 320)	Denham Bros. (R'ton) Pty. Ltd., East street, Rockhampton
Tickstroy (Double Strength) Cattle Dip	64-0 Arsenic Trioxide (As ₂ O ₃) (dilution 1 in 320)	J. H. Eden & Co., 483 Lutwyche road, Lutwyche, Brisbane
Harton Cattle Dip	64-0 Arsenic Trioxide (As ₂ O ₃) 7-2 Cresols (dilution 1 in 320)	Goldsborough, Mort & Co. Ltd., Eagle street, Brisbane
Hayes' Cattle Dip	60-0 Arsenic Trioxide (As ₂ O ₃) 9-5 Cresylic Acid (dilution 1 in 300)	Hayes Veterinary Co., 351 Queen street, Brisbane
"Vallo" Improved Fluid Cattle Dip Double Strength	64-0 Arsenic Trioxide (As ₂ O ₃) 7-35 Cresylic Acid (dilution 1 in 320)	A. Victor Leggo & Co Pty. Ltd., 185 Mary street, Brisbane
Maxdip Double Strength Cattle Dip	64-0 Arsenic Trioxide (As ₂ O ₃) (dilution 1 in 320)	Mactaggart's P.P. Co-op. Assn. Ltd., Eagle street, Brisbane
Cooper's Tixol	64-0 Arsenic Trioxide (As ₂ O ₃) 5-2 Cresylic Acid (dilution 1 in 320)	New Zealand Loan & Mercantile Agency Co. Ltd., Eagle street, Brisbane
Sidolia Highly Concentrated Liquid Cattle Dip	64-0 Arsenic Trioxide (As ₂ O ₃) 10-0 Cresylic Acid (dilution 1 in 320)	Norris Agencies Pty. Ltd., 639 Ann street, Brisbane
Osmond's "Forty-One" Cattle Dip	65-60 Arsenic Trioxide (As ₂ O ₃) (dilution 1 in 325)	Osmonds & Sons (Aust.) Pty. Ltd., 500 Stanley street, South Brisbane
I.C.D. 1-320 Liquid Cattle Dip	64-0 Arsenic Trioxide (As ₂ O ₃) (dilution 1 in 320)	Port Curtis Co-op. Dairy Assn. Ltd., O'Connell street, Gladstone
Young's Improved Cattle Dip	64-0 Arsenic Trioxide (As ₂ O ₃) 5-0 Cresylic Acid and Homologues (dilution 1 in 320)	Producers Co-op. Dist. Soc. Ltd., Turbot street, Brisbane
Standard Liquid Cattle Dip, Double Strength, 1-300	60-0 Arsenic Trioxide (As ₂ O ₃) (dilution 1 in 300)	Queensland Chemical & Distributing Co., 107 Eagle street, Brisbane
Hibiscus Cattle Dip Fluid	64-0 Arsenic Trioxide (As ₂ O ₃) 7-2 Cresylic Acid (dilution 1 in 320)	Queensland Pastoral Supplies Pty. Ltd., Bowen street, Brisbane
Young's Standard Sodium Arsenite Cattle Dip	64-0 Arsenic Trioxide (As ₂ O ₃) (dilution 1 in 320)	Queensland Primary Producers Co-op. Assn. Ltd., Creek street, Brisbane
Kiltie Concentrated Liquid Cattle Dip	60-0 Arsenic Trioxide (As ₂ O ₃) 9-5 Tar Acids (dilution 1 in 300)	Surgical Supplies Ltd., 428 Queen street, Brisbane
Tropik 1-320 Liquid Cattle Dip	64-0 Arsenic Trioxide (As ₂ O ₃) (dilution 1 in 320)	Tropical Dip & Chemical Co., Cambridge street, Rockhampton
Uceol Cattle Dip	64-0 Arsenic Trioxide (As ₂ O ₃) (dilution 1 in 320)	United Chemicals Pty. Ltd., 91-7 Montague road, South Brisbane
Little's Cattle Dip (Concentrated)	60-0 Arsenic Trioxide (As ₂ O ₃) (dilution 1 in 300)	Wilcox, Moffin Ltd., Albert street, Brisbane
"Apollo" Cattle Dip, Double Strength	60-0 Arsenic Trioxide (As ₂ O ₃) (dilution 1 in 300)	Winchcombe. Carson Ltd., 99 Eagle street, Brisbane
ARSENICAL—PASTE.		
Thomas' Carbollised Cattle Wash	35-2 Arsenic Trioxide (As ₂ O ₃) 0-25 Cresylic Acid (10lb. to 175 gallons)	James Campbell & Sons Pty. Ltd., Creek street, Brisbane
BENZENE HEXACHLORIDE—LIQUID.		
Royal A.R.T. Cattle Dip	6-0 gamma isomer of Benzene Hexachloride	Dalgety & Co. Ltd., Elizabeth street, Brisbane
Cooper's Gamatik Cattle Dip	6-0 gamma isomer of Benzene Hexachloride	New Zealand Loan & Mercantile Agency Co. Ltd., Eagle street, Brisbane
Little's Altik Cattle Dip	6-0 gamma isomer of Benzene Hexachloride	Wilcox, Moffin Ltd., Albert street, Brisbane
BENZENE HEXACHLORIDE—PASTE.		
Young's Sovereign Paste Cattle Dip	6-5 gamma isomer of Benzene Hexachloride	Queensland Primary Producers' Co-op. Assn. Ltd., Creek street, Brisbane

BENZENE HEXACHLORIDE AND DDT.

Osmond's "Vidix" Cattle Dip	25-0	para para dichlorodiphenyltrichlorethane	} Osmond & Sons (Aust.) Pty. Ltd., 500 Stanley street, South Brisbane
	1-5	gamma isomer of Benzene Hexachloride	
	5-0	Cresylic Acid	
CHLORATE WEED KILLERS.			
A.C.F. Sodium Chlorate Non-Poisonous Weed Killer	100-0	Commercial Sodium Chlorate	A.C.F. & Shirleys Fertilizers Ltd., Little Roma street, Brisbane
Atlaide C.A. Chlorate Weed Killer	19-2	Chlorine (Cl) as Calcium Chloride	} Imperial Chemical Industries of Aust. & N.Z. Ltd., 293 Queen street, Brisbane
Elliott's Vertan	20-0	Chlorine (Cl) as Sodium Chlorate	
	33-0	Chlorine (Cl) as Sodium Chlorate	

COPPER DUSTS.

I.C.I. Copper Carbonate	52-0	Copper (Cu) as Copper Carbonate	} Imperial Chemical Industries of Aust. & N.Z. Ltd., 293 Queen street, Brisbane
Smuto	52-0	Copper (Cu) as Copper Oxide	
"Vallo" Anti-Bunt	50-0	Copper (Cu) as Copper Oxide	
		Copper (Cu) as Copper Oxide	A. Victor Leggo & Co. Pty. Ltd., 185 Mary street, Brisbane

COPPER SPRAYS.

Aeroflo C-O-C Spray	50-0	Copper (Cu) as Copper Oxide	} Aeroflo Dusts & Sprays Pty., Redland Bay road, Redland Bay
F.D.L. Copper Spray	50-0	Copper (Cu) as Copper Oxide	
Bordinette	12-7	Copper (Cu) as Copper Sulphate	
			Fertiliser Distributors Pty. Ltd., Little Roma street, Brisbane
			Qld. Fruitgrowers' Co-op. Soc. Ltd., Makerston street, Brisbane

COPPER SULPHATE.

Bluestone	25-0	Copper (Cu) as Copper Sulphate	A.C.F. & Shirleys Fertilizers Ltd., Little Roma Street, Brisbane
Bluestone (Copper Sulphate)	25-0	Copper (Cu) as Copper Sulphate	G. Horaburgh & Co. Pty. Ltd., 320 Kent street, Maryborough

CYANIDE.

Cyanogas	42-0	Calcium Cyanide (Ca (CN) ₂)	Buzacotts (Qld.), Ltd., 443 Adelaide street, Petrie Bight, Brisbane
----------------	------	---	---

DERRIS PREPARATIONS.

Nosco Derris Dust	0-75	Rotenone	from	} A. G. Bignold & Co., 169 Elizabeth street, Brisbane
	1-25	Total Ether Extractives	Derris	
	0-8	Rotenone	from	
Houghton's Derridust No. 1	3-0	Total Ether Extractives	Derris	} Houghton & Byrne Pty., Ltd., Queen street, Brisbane
	1-0	Rotenone	from	
	3-0	Total Ether Extractives	Derris	
Pulvex Vermin Powder	1-0	Rotenone	from	} New Zealand Loan & Mercantile Agency Co. Ltd., Eagle street, Brisbane
	3-0	Total Ether Extractives	Derris	
	4-0	Total Ether Extractives	Derris	
Katakilla	0-025	Rotenone	from	} Queensland Fruitgrowers Co-op. Soc. Ltd., Makerston street, Brisbane
	0-1	Total Ether Extractives	Derris	
	35-0	Potassium and Ammonium Oleate	
Hart's Agricultural Pesticide	2-0	Oil of Citronella	} Queensland Pastoral Supplies Pty. Ltd., Bowen street, Brisbane
	0-625	Rotenone	from	
	2-5	Total Ether Extractives	Derris	
Elliott's Rodeo	35-0	Cresylic Acid	Taylor's, Elliott's Pty. Ltd., 150 Charlotte street, Brisbane

DUSTING MIXTURES.

BENZENE HEXACHLORIDE & DDT.			
Aeroflo DDT 113	1-0	para para dichlorodiphenyltrichlorethane	} Aeroflo Dusts & Sprays Pty., Redland Bay Road, Redland Bay
	0-13	gamma isomer of Benzene Hexachloride	
	2-0	para para dichlorodiphenyltrichlorethane	
Aeroflo DG. 226	0-26	gamma isomer of Benzene Hexachloride	} Aeroflo Dusts & Sprays Pty., Redland Bay Road, Redland Bay
	0-5	gamma isomer of Benzene Hexachloride	
	1-0	para para dichlorodiphenyltrichlorethane	
Gammexane No. 4 Dust	0-13	gamma isomer of Benzene Hexachloride	} Imperial Chemical Industries of Aust. & N.Z. Ltd., 293 Queen street, Brisbane
Pespruf No. 2G Dust	2-0	para para dichlorodiphenyltrichlorethane	
	0-26	gamma isomer of Benzene Hexachloride	
Pespruf No. 4G Dust	2-0	para para dichlorodiphenyltrichlorethane	} Imperial Chemical Industries of Aust. & N.Z. Ltd., 293 Queen street, Brisbane
	0-26	gamma isomer of Benzene Hexachloride	
	2-0	para para dichlorodiphenyltrichlorethane	
Neptune Float-On Dust No. 8	0-26	gamma isomer of Benzene Hexachloride	Neptune Oil Co. Pty. Ltd., 301-7 Ann street, Brisbane

LIST OF PEST DESTROYERS REGISTERED IN QUEENSLAND UNDER "THE PEST DESTROYERS ACT OF 1939."—*continued.*
For the Period Commencing January, 1949, as at 2nd December, 1949.

Name of Pest Destroyer.	Active Constituents as Declared by Seller.	Queensland Wholesale Dealer.
<i>DUSTING MIXTURES—continued.</i>		
BENZENE HEXACHLORIDE & DDT.— <i>cont'd.</i>	Per cent.	
Plane Brand Noxide No. 100 G2	1-0 para para dichlordiphenyltrichlorethane 0-26 gamma isomer of Benzene Hexachloride	Queensland Fruitgrowers' Co-op. Soc. Ltd., Makerston street, Brisbane
Vege-Dust (Noxide 100 G4)	1-0 para para dichlordiphenyltrichlorethane 0-4 gamma isomer of Benzene Hexachloride	Queensland Fruitgrowers' Co-op. Soc. Ltd., Makerston street, Brisbane
Rudust No. 8 Duplex Cabbage Dust	2-0 para para dichlordiphenyltrichlorethane 0-26 gamma isomer of Benzene Hexachloride	Taubmans (Qld.) Pty. Ltd., 95 Edward street, Brisbane
A.C.F. Peskil	2-0 para para dichlordiphenyltrichlorethane 7-0 Copper (Cu) as Copper Oxychloride	A.C.F. & Shirley Fertilizers Ltd., Little Roma street, Brisbane
Aeroflo CD 72 Dust	40-0 Sulphur (S) as Powdered Sulphur 7-0 Copper (Cu) as Copper Oxychloride	Aeroflo Dusts & Sprays Pty., Redland Bay road, Redland Bay
Aeroflo CSD 7402 Dust	2-0 para para dichlordiphenyltrichlorethane 7-0 Copper (Cu) as Copper Oxychloride	Aeroflo Dusts & Sprays Pty., Redland Bay road, Redland Bay
Aeroflo CSD 10/402 Dust	40-0 Sulphur (S) as Powdered Sulphur 10-0 Copper (Cu) as Copper Oxychloride	Aeroflo Dusts & Sprays Pty., Redland Bay road, Redland Bay
Aeroflo DS 260 Dust	2-0 para para dichlordiphenyltrichlorethane 60-0 Sulphur (S) as Powdered Sulphur	Aeroflo Dusts & Sprays Pty., Redland Bay road, Redland Bay
Lane's Tomato Dust No. 1	2-0 para para dichlordiphenyltrichlorethane 42-0 Sulphur (S)	A. G. Bignold & Co., 169 Elizabeth street, Brisbane
Nosco Brand Composite Dust	4-0 Copper (Cu) as Copper Oxychloride 2-0 para para dichlordiphenyltrichlorethane	A. G. Bignold & Co., 169 Elizabeth street, Brisbane
Garden Brand DDT Combined Dust	0-1 Pyrethrins 25-0 Tobacco Dust	Cloudust Spray Manufacturers, Montague road, South Brisbane
F.D.L. No. 4 Dust	1-0 para para dichlordiphenyltrichlorethane 0-5 Rotenone 1-2 Total Ether Extractives	from Timbo
Pespruf No. 5 Dust	2-0 para para dichlordiphenyltrichlorethane 7-0 Copper (Cu) as Copper Oxychloride	Fertiliser Distributors Pty. Ltd., Little Roma street, Brisbane
Pespruf No. 3 Dust	40-0 Sulphur (S) as Ground Sulphur 2-0 para para dichlordiphenyltrichlorethane	Imperial Chemical Industries of Aust. & N.Z. Ltd., 293 Queen street, Brisbane
Neptune Float-On Dust No. 4	7-5 Copper (Cu) as Basic Copper Carbonate 2-0 para para dichlordiphenyltrichlorethane	Imperial Chemical Industries of Aust. & N.Z. Ltd., 293 Queen street, Brisbane
Neptune Float-On Dust No. 5	7-0 Copper (Cu) as Basic Copper Carbonate 2-0 para para dichlordiphenyltrichlorethane	Neptune Oil Co. Pty. Ltd., 301-7 Ann street, Brisbane
Plane Brand Azurine No. 200	0-13 Total Pyrethrins 2-0 para para dichlordiphenyltrichlorethane	Neptune Oil Co. Pty. Ltd., 301-7 Ann street, Brisbane
Pestox No. 3 DDT Dust	5-0 Copper (Cu) as Copper Oxychloride 2-0 para para dichlordiphenyltrichlorethane	Queensland Fruitgrowers Co-op. Soc. Ltd., Makerston street, Brisbane
Pestox No. 5 DDT Dust	40-0 Sulphur (S) as Powdered Sulphur 2-0 para para dichlordiphenyltrichlorethane	L. L. Strange, Rep. Samuel Taylor Pty. Ltd., "Sunnyside," Miles street, Hawthorne, Brisbane
	0-23 Total Pyrethrins 20-0 Sulphur (S)	L. L. Strange, Rep. Samuel Taylor Pty. Ltd., "Sunnyside," Miles street, Hawthorne, Brisbane

Rudust No. 7 Tropical Tomato Dust	2-0 para para dichlorodiphenyltrichlorethane ..	Taubmans (Qld.) Pty. Ltd., 95 Edward street, Brisbane
	50-0 Sulphur (S) as Finely Ground Sulphur ..	
Rudust Tomato Dust No. 2 ..	7-0 Copper (Cu) as Copper Carbonate ..	Taubmans (Qld.) Pty. Ltd., 95 Edward street, Brisbane
	2-0 para para dichlorodiphenyltrichlorethane ..	
	50-0 Sulphur (S) as Finely Ground Sulphur ..	
MISCELLANEOUS.		
A.C.F. Blight Dust ..	7 28 Copper (Cu) as Copper Carbonate ..	A.C.F. & Shirleys Fertilizers, Ltd., Little Roma street, Brisbane
	40-0 Sulphur (S) as Powdered Sulphur ..	
A.C.F. Complete Dust ..	7-75 Arsenic Pentoxide (As ₂ O ₅) as Arsenate of Lead	
	5-0 Copper (Cu) as Dehydrated Copper Sulphate ..	A. C. F. & Shirleys Fertilizers Ltd., Little Roma street, Brisbane
	2-0 Nicotine (C ₁₀ H ₁₁ N ₂) as Nicotine Sulphate ..	
	20-0 Sulphur (S) as Powdered Sulphur ..	
A.C.F. Copper Lead Dust ..	5-0 Copper (Cu) as Dehydrated Copper Sulphate ..	A. C. F. & Shirleys Fertilizers Ltd., Little Roma street, Brisbane
	10-0 Sulphur (S) as Powdered Sulphur ..	
A.C.F. Copper Sulphate Dust ..	12-4 Arsenic Pentoxide (As ₂ O ₅) as Lead Arsenate	
	5-0 Copper (Cu) as Dehydrated Copper Sulphate ..	A. C. F. & Shirleys Fertilizers Ltd., Little Roma street, Brisbane
A.C.F. Grub and Aphid Dust ..	10-0 Sulphur (S) as Powdered Sulphur ..	
	7-75 Arsenic Pentoxide (As ₂ O ₅) as Lead Arsenate	A. C. F. & Shirleys Fertilizers Ltd., Little Roma street, Brisbane
	2-0 Nicotine (C ₁₀ H ₁₁ N ₂) as Nicotine Sulphate ..	
A.C.F. Home Garden Dusting Powder	7-75 Arsenic Pentoxide (As ₂ O ₅) as Lead Arsenate	
	5-4 Copper (Cu) Dehydrated Copper Sulphate ..	A. C. F. & Shirleys Fertilizers Ltd., Little Roma street, Brisbane
	2-0 Nicotine (C ₁₀ H ₁₁ N ₂) as Nicotine Sulphate ..	
A.C.F. Special Blight Dust ..	20-0 Sulphur (S) as Powdered Sulphur ..	A. C. F. & Shirleys Fertilizers Ltd., Little Roma street, Brisbane
	10-0 Copper (Cu) as Copper Carbonate ..	
	40-0 Sulphur (S) as Powdered Sulphur ..	A. C. F. & Shirleys Fertilizers Ltd., Little Roma street, Brisbane
A.C.F. Special Grub and Aphid Dust	15-5 Arsenic Pentoxide (As ₂ O ₅) as Lead Arsenate	
	2-0 Nicotine (C ₁₀ H ₁₁ N ₂) as Nicotine Sulphate ..	A. C. F. & Shirleys Fertilizers Ltd., Little Roma street, Brisbane
A.C.F. Special Grub Dust ..	15-5 Arsenic Pentoxide (As ₂ O ₅) as Lead Arsenate	
	7-0 Copper (Cu) as Copper Carbonate ..	A. C. F. & Shirleys Fertilizers Ltd., Little Roma street, Brisbane
A.C.F. Special Tomato Dust ..	40-0 Sulphur (S) as Powdered Sulphur ..	
	12-0 Arsenic Pentoxide (As ₂ O ₅) as Lead Arsenate	
A.C.F. Tomato 50 Dust ..	7-0 Copper (Cu) as Copper Carbonate ..	A. C. F. & Shirleys Fertilizers Ltd., Little Roma street, Brisbane
	20-0 Sulphur (S) as Powdered Sulphur ..	
	15-5 Arsenic Pentoxide (As ₂ O ₅) as Arsenate of Lead	
A.C.F. Tomato and Meion Dust ..	7-28 Copper (Cu) as Copper Carbonate ..	A. C. F. & Shirleys Fertilizers Ltd., Little Roma street, Brisbane
	40-0 Sulphur (S) as Powdered Sulphur ..	
	7-75 Arsenic Pentoxide (As ₂ O ₅) as Lead Arsenate	
Aeroflo CS. 740 Dust ..	7-0 Copper (Cu) as Copper Oxychloride ..	Aeroflo Dusts & Sprays Pty., Redland Bay road, Redland Bay
	40-0 Sulphur (S) as Powdered Sulphur ..	
Aeroflo CS. 760 Dust ..	7-0 Copper (Cu) as Copper Oxychloride ..	Aeroflo Dusts & Sprays Pty., Redland Bay road, Redland Bay
	60-0 Sulphur (S) as Powdered Sulphur ..	
Aeroflo CS. 1140 Dust ..	11-0 Copper (Cu) as Copper Oxychloride ..	Aeroflo Dusts & Sprays Pty., Redland Bay road, Redland Bay
	40-0 Sulphur (S) as Powdered Sulphur ..	
Aeroflo CSL. 25 Dust ..	7-0 Copper (Cu) as Copper Oxychloride ..	Aeroflo Dusts & Sprays Pty., Redland Bay road, Redland Bay
	40-0 Sulphur (S) as Powdered Sulphur ..	
	7-75 Arsenic Pentoxide (As ₂ O ₅) as Arsenate of Lead	
Aeroflo CSL. 40 Dust ..	7-0 Copper (Cu) as Copper Oxychloride ..	Aeroflo Dusts & Sprays Pty., Redland Bay road, Redland Bay
	40-0 Sulphur (S) as Powdered Sulphur ..	
	12-0 Arsenic Pentoxide (As ₂ O ₅) as Arsenate of Lead	
Aeroflo CSL 40X Dust ..	10-0 Copper (Cu) as Copper Oxychloride ..	Aeroflo Dusts & Sprays Pty., Redland Bay road, Redland Bay
	20-0 Sulphur (S) as Powdered Sulphur ..	
	12-0 Arsenic Pentoxide (As ₂ O ₅) as Arsenate of Lead	
Aeroflo CSL 50 Dust ..	7-0 Copper (Cu) as Copper Oxychloride ..	Aeroflo Dusts & Sprays Pty., Redland Bay road, Redland Bay
	20-0 Sulphur (S) as Powdered Sulphur ..	
	15-5 Arsenic Pentoxide (As ₂ O ₅) as Arsenate of Lead	
Aeroflo LN 502 Dust ..	15-5 Arsenic Pentoxide (As ₂ O ₅) as Arsenate of Lead	Aeroflo Dusts & Sprays Pty., Redland Bay road, Redland Bay
	2-0 Nicotine (C ₁₀ H ₁₁ N ₂) as Nicotine Sulphate ..	
Aeroflo S 90 Dust ..	90-0 Sulphur (S) as Powdered Sulphur ..	Aeroflo Dusts & Sprays Pty., Redland Bay road, Redland Bay
	50-0 Sulphur (S) as Powdered Sulphur ..	
Aeroflo SN 502 Dust ..	2-0 Nicotine (C ₁₀ H ₁₁ N ₂) as Nicotine Sulphate ..	Aeroflo Dusts & Sprays Pty., Redland Bay road, Redland Bay

LIST OF PEST DESTROYERS REGISTERED IN QUEENSLAND UNDER "THE PEST DESTROYERS ACT OF 1939."—*continued.*

For the Period Commencing January, 1949, as at 2nd December, 1949.

Name of Pest Destroyer.	Active Constituents as Declared by Seller.	Queensland Wholesale Dealer.
DUSTING MIXTURES—<i>continued.</i>		
<i>MISCELLANEOUS—continued.</i>		
	Per cent.	
Cloudust Blight Dust	7.5 Copper (Cu) as Copper Carbonate	Cloudust Spray Manufacturers, Montague road, South Brisbane
	30.0 Sulphur (S) as Ground Sulphur	
Cloudust Tomato Dust Special	12.2 Arsenic Pentoxide (As ₂ O ₅) as Arsenate of Lead	Cloudust Spray Manufacturers, Montague road, South Brisbane
	7.5 Copper (Cu) as Copper Carbonate	
Waratah Brand Dust No. 1	30.0 Sulphur (S) Ground Sulphur	Committee of Direction of Fruit Marketing, Turbot street, Brisbane
	5.0 Copper (Cu) as Copper Carbonate	
F.D.L. Dust No. 1	20.0 Sulphur (S) as Ground Sulphur	Fertiliser Distributors Pty. Ltd., Little Roma street, Brisbane
	7.0 Copper (Cu) as Copper Oxylchloride	
F.D.L. Dust No. 2	40.0 Sulphur (S) as Ground Sulphur	Fertiliser Distributors Pty. Ltd., Little Roma street, Brisbane
	11.0 Copper (Cu) as Copper Oxylchloride	
F.D.L. Dust No. 3	35.0 Sulphur (S) as Ground Sulphur	Fertiliser Distributors Pty. Ltd., Little Roma street, Brisbane
	12.5 Arsenic Pentoxide (As ₂ O ₅) as Arsenate of Lead	
"Vallo" Dusting Compound A.L. 50	7.0 Copper (Cu) as Copper Oxylchloride	A. Victor Leggo & Co. Pty. Ltd., 185 Mary street, Brisbane
	40.0 Sulphur (S) as Ground Sulphur	
"Vallo" Dusting Compound N3 AL. 30	16.0 Arsenic Pentoxide (As ₂ O ₅) as Arsenate of Lead	A. Victor Leggo & Co. Pty. Ltd., 185 Mary street, Brisbane
	3.0 Nicotine (C ₁₀ H ₁₁ N)	
"Vallo" Tomato and Vegetable Dusting Compound No. 1	9.6 Arsenic Pentoxide (As ₂ O ₅) as Arsenate of Lead	A. Victor Leggo & Co. Pty. Ltd., 185 Mary street, Brisbane
	15.0 Arsenic Pentoxide (As ₂ O ₅) as Arsenate of Lead	
"Vallo" Tomato and Vegetable Dusting Compound No. 2	5.0 Copper (Cu) as Copper Oxylchloride	A. Victor Leggo & Co. Pty. Ltd., 185 Mary street, Brisbane
	40.0 Sulphur (S)	
Neptune Floa-On Dust No. 6	15.0 Arsenic Pentoxide (As ₂ O ₅) as Arsenate of Lead	Neptune Oil Co. Pty. Ltd., 301-7 Ann street, Brisbane
	5.0 Copper (Cu) as Copper Oxylchloride	
Plane Brand Azurine No. 2 Dust	40.0 Sulphur (S) as Powdered Sulphur	Queensland Fruitgrowers Co-op. Soc. Ltd., Makerston street, Brisbane
	7.0 Copper (Cu) as Copper Oxylchloride	
Plane Brand Azurine No. 4 Dust	40.0 Sulphur (S) as Powdered Sulphur	Queensland Fruitgrowers Co-op. Soc. Ltd., Makerston street, Brisbane
	11.0 Copper (Cu) as Copper Oxylchloride	
Plane Brand Azurine No. 25 Dust	35.0 Sulphur (S) as Powdered Sulphur	Queensland Fruitgrowers Co-op. Soc. Ltd., Makerston street, Brisbane
	7.0 Copper (Cu) as Copper Oxylchloride	
Plane Brand Azurine No. 40 Dust	40.0 Sulphur (S) as Powdered Sulphur	Queensland Fruitgrowers Co op. Soc. Ltd., Makerston street, Brisbane
	7.5 Arsenic Pentoxide (As ₂ O ₅) as Arsenate of Lead	
	7.0 Copper (Cu) as Copper Oxylchloride	
	40.0 Sulphur (S) as Powdered Sulphur	
	12.0 Arsenic Pentoxide (As ₂ O ₅) as Arsenate of Lead	
DDT PREPARATIONS.		
A.C.F. DDT 2 per cent. Dust	2.0 para para dichlorodiphenyltrichlorethane	A. C. F. & Shirleys Fertilizers Ltd., Little Roma street, Brisbane
A.C.F. DDT 4 per cent. Solution	4.0 para para dichlorodiphenyltrichlorethane	A. C. F. & Shirleys Fertilizers Ltd., Little Roma street, Brisbane
A.C.F. 20 per cent. DDT Spray	20.0 para para dichlorodiphenyltrichlorethane	A. C. F. & Shirleys Fertilizers Ltd., Little Roma street, Brisbane
Aeroflo DDT 200 Dust	2.0 para para dichlorodiphenyltrichlorethane	Aeroflo Dusts & Sprays Pty., Redland Bay road, Redland Bay
	5.0 para para dichlorodiphenyltrichlorethane	
Kylpest	4.0 Total Ether Extractives } from Barbascue	A. G. Bignold & Co., 169 Elizabeth street, Brisbane
	1.3 Rotenone } Root	

Lane's Emulsane 20 DDT Emulsion	20-0	para para dichlordiphenyltrichlorethane	A. G. Bignold & Co., 169 Elizabeth street, Brisbane
Lane's No-Verm Dust	2-0	para para dichlordiphenyltrichlorethane	A. G. Bignold & Co., 169 Elizabeth street, Brisbane
Lane's Well spray 50 Dispersible 50 per cent. DDT Powder	2-0	para para dichlordiphenyltrichlorethane	A. G. Bignold & Co., 169 Elizabeth street, Brisbane
Lane's Well spray Emulsion	25-0	para para dichlordiphenyltrichlorethane	A. G. Bignold & Co., 169 Elizabeth street, Brisbane
Australian 20 per cent. DDT Emulsion	20-0	para para dichlordiphenyltrichlorethane	H. Blaiklock & Co. Pty. Ltd., 150 Mary street, Brisbane
Taylor's No. 13 DDT Emulsion Concentrate	9-5	para para dichlordiphenyltrichlorethane	F. C. Rowley, Rep. British Paints (Aust.) Pty. Ltd., 115 Queen street, Brisbane
Taylor's No. 13 DDT Powder	5-0	para para dichlordiphenyltrichlorethane	F. C. Rowley, Rep. British Paints (Aust.) Pty. Ltd., 115 Queen street, Brisbane
Garden Brand Blue Label Dispersable DDT Powder	40-0	para para dichlordiphenyltrichlorethane	Cloudust Spray Manufacturers, Montague road, South Brisbane
Garden Brand DDT 2 per cent.	2-0	para para dichlordiphenyltrichlorethane	Cloudust Spray Manufacturers, Montague road, South Brisbane
Garden Brand Green Label Dispersable DDT Powder	40-0	para para dichlordiphenyltrichlorethane	Cloudust Spray Manufacturers, Montague road, South Brisbane
Buflidi	5-0	para para dichlordiphenyltrichlorethane	Denham Bros. (R'ton) Pty. Ltd., East street, Rockhampton
Ex-L-Coi 5 per cent. DDT Emulsion	5-0	para para dichlordiphenyltrichlorethane	Denham Bros. (R'ton) Pty. Ltd., East street, Rockhampton
F.D.L. DDT 2 per cent. Dust	2-0	para para dichlordiphenyltrichlorethane	Fertiliser Distributors Pty. Ltd., Little Roma street, Brisbane
F.D.L. 20 per cent. Emulsion	20-0	para para dichlordiphenyltrichlorethane	Fertiliser Distributors Pty. Ltd., Little Roma street, Brisbane
F.D.L. DDT 50 Spray	50-0	para para dichlordiphenyltrichlorethane	Fertiliser Distributors Pty. Ltd., Little Roma street, Brisbane
Magic Pest & Vermin Exterminator	10-0	para para dichlordiphenyltrichlorethane	Gibbs, Bright & Co., 406 Queen street, Brisbane
Mag-O-Tol plus DDT	4-0	Cresylic Acid	Goldsborough, Mort & Co. Ltd., Eagle street, Brisbane
Mag-O-Tol plus DDT	1-0	para para dichlordiphenyltrichlorethane	Goldsborough, Mort & Co. Ltd., Eagle street, Brisbane
I.C.I. Buffalo Fly Emulsion No. 1	15-0	para para dichlordiphenyltrichlorethane	Imperial Chemical Industries of Aust. & N.Z. Ltd., 293 Queen street, Brisbane
Pespruf 50 per cent. Dispersible Powder	50-0	para para dichlordiphenyltrichlorethane	Imperial Chemical Industries of Aust. & N.Z. Ltd., 293 Queen street, Brisbane
Pespruf No. 2 Dust	2-0	para para dichlordiphenyltrichlorethane	Imperial Chemical Industries of Aust. & N.Z. Ltd., 293 Queen street, Brisbane
"Vermpruf" 1A	12-5	para para dichlordiphenyltrichlorethane	Imperial Chemical Industries of Aust. & N.Z. Ltd., 293 Queen street, Brisbane
Chemist Roush DDT All Purpose Insect Spray	3-2	para para dichlordiphenyltrichlorethane	Morden Laboratories, 66 Charlotte street, Brisbane
Chemist Roush DDT Dog Soap	2-0	para para dichlordiphenyltrichlorethane	Morden Laboratories, 66 Charlotte street, Brisbane
Chemist Roush Fly and Insect Spray	0-1	Active Pyrethrins	Morden Laboratories, 66 Charlotte street, Brisbane
Morden Flea and Vermin Powder for Dogs	0-4	para para dichlordiphenyltrichlorethane	Morden Laboratories, 66 Charlotte street, Brisbane
Neptune Aphidol	5-0	para para dichlordiphenyltrichlorethane	Morden Laboratories, 66 Charlotte street, Brisbane
Neptune Aphidol	4-0	para para dichlordiphenyltrichlorethane	Morden Laboratories, 66 Charlotte street, Brisbane
Neptune DDT Dispersible Powder	78-0	Refined Mineral Oil	Neptune Oil Co. Pty. Ltd., 301-7 Ann street, Brisbane
Neptune DDT Spraying Emulsion	40-0	para para dichlordiphenyltrichlorethane	Neptune Oil Co. Pty. Ltd., 301-7 Ann street, Brisbane
Neptune Float-On Dust No. 1	32-0	para para dichlordiphenyltrichlorethane	Neptune Oil Co. Pty. Ltd., 301-7 Ann street, Brisbane
Neptune Float-On Dust No. 2	5-0	para para dichlordiphenyltrichlorethane	Neptune Oil Co. Pty. Ltd., 301-7 Ann street, Brisbane
Neptune Float-On Dust No. 2	2-0	para para dichlordiphenyltrichlorethane	Neptune Oil Co. Pty. Ltd., 301-7 Ann street, Brisbane
Insectbane	0-587	Total Pyrethrins (1 and 2)	Nobles Pty. Ltd., cnr. Charlotte and Eagle streets, Brisbane
Insectbane	2-0	para para dichlordiphenyltrichlorethane	Nobles Pty. Ltd., cnr. Charlotte and Eagle streets, Brisbane
Wonderdog Tick Powder	10-0	para para dichlordiphenyltrichlorethane	Nobles Pty. Ltd., cnr. Charlotte and Eagle streets, Brisbane
Wonderdog Tick Powder	1-0	Rotenone	Nobles Pty. Ltd., cnr. Charlotte and Eagle streets, Brisbane
Wonderdog Tick Powder	3-0	Total Ether Extractives	Nobles Pty. Ltd., cnr. Charlotte and Eagle streets, Brisbane
Wonderdog Tick Powder	3-0	para para dichlordiphenyltrichlorethane	Nobles Pty. Ltd., cnr. Charlotte and Eagle streets, Brisbane
Wonderdog Vermin Powder	1-0	Rotenone	Nobles Pty. Ltd., cnr. Charlotte and Eagle streets, Brisbane
Wonderdog Vermin Powder	3-0	Total Ether Extractives	Nobles Pty. Ltd., cnr. Charlotte and Eagle streets, Brisbane
Wonderdog Vermin Powder	1-0	Rotenone	Nobles Pty. Ltd., cnr. Charlotte and Eagle streets, Brisbane
Krect Vermin Powder	4-0	Total Ether Extractives	Nobles Pty. Ltd., cnr. Charlotte and Eagle streets, Brisbane
Krect Vermin Powder	2-0	para para dichlordiphenyltrichlorethane	Nobles Pty. Ltd., cnr. Charlotte and Eagle streets, Brisbane
P.C.D. FH-Tik-Di	20-0	para para dichlordiphenyltrichlorethane	Nobles Pty. Ltd., cnr. Charlotte and Eagle streets, Brisbane
Mothdust 2 per cent. DDT	2-0	para para dichlordiphenyltrichlorethane	Nobles Pty. Ltd., cnr. Charlotte and Eagle streets, Brisbane
Kilsect 20 per cent. DDT Emulsion Concentrate	20-0	para para dichlordiphenyltrichlorethane	Nobles Pty. Ltd., cnr. Charlotte and Eagle streets, Brisbane
Dee Dust	2-0	para para dichlordiphenyltrichlorethane	Nobles Pty. Ltd., cnr. Charlotte and Eagle streets, Brisbane
Hibiscus DDT Emulsion Concentrate	20-0	para para dichlordiphenyltrichlorethane	Nobles Pty. Ltd., cnr. Charlotte and Eagle streets, Brisbane
Toxol DDT Vermin Powder	2-0	para para dichlordiphenyltrichlorethane	Nobles Pty. Ltd., cnr. Charlotte and Eagle streets, Brisbane
Kadol Concentrated 20 per cent. DDT Emulsion	20-0	para para dichlordiphenyltrichlorethane	Nobles Pty. Ltd., cnr. Charlotte and Eagle streets, Brisbane
Verm-X Insect Powder	3-0	para para dichlordiphenyltrichlorethane	Nobles Pty. Ltd., cnr. Charlotte and Eagle streets, Brisbane
Verm-X Insect Powder	0-65	Pyrethrins	Nobles Pty. Ltd., cnr. Charlotte and Eagle streets, Brisbane

[TO BE CONTINUED.]

1950 SHOW DATES.

April.	
Blackbutt ..	13, 14 and 15
Chinchilla ..	13, 14 and 15
Miles ..	20, 21 and 22
Monto ..	26 and 27
Taroom ..	26, 27 and 28
Nanango ..	27, 28 and 29
Wallumbilla ..	27 and 29

May.	
Eidsvold ..	1 and 2
Roma ..	2, 3 and 4
Kingaroy ..	4, 5 and 6
Beaudesert ..	5 and 6
Inglewood ..	5 and 6
Wondai ..	11, 12 and 13
Marburg ..	12 and 13
Ipswich ..	16, 17 and 18
Blackall ..	16 and 17
Charleville ..	17 and 18
Biggenden ..	18 and 19
Murgon ..	18, 19 and 20
Thangool ..	19 and 20
Warrill View ..	20
Biloela ..	25 and 26
Gympie ..	25, 26 and 27
Crow's Nest ..	26 and 27
Kalbar ..	27

June.	
Maryborough ..	1, 2 and 3
Wowan ..	1, 2 and 3
Boonah ..	2 and 3
Childers ..	5 and 6
Bundaberg ..	8, 9 and 10
Mt. Morgan ..	8, 9 and 10

Lowood ..	9, 10 and 12
Gin Gin ..	12 and 13
Gladstone ..	15, 16 and 17
Toogoolawah ..	16 and 17
Rockhampton ..	21, 22, 23 and 24
Kileoy ..	23 and 24
Mackay ..	27, 28 and 29
Esk ..	30 and 1st July
Proserpine ..	30 and 1st July
Home Hill ..	30 and 1st July

July.	
Bowen ..	5 and 6
Nambour ..	6, 7 and 8
Ayr ..	7 and 8
Laidley ..	7 and 8
Townsville ..	11, 12, and 13
Maleny ..	13 and 14
Ingham ..	14 and 15
Rosewood ..	14 and 15
Cairns ..	18, 19 and 20
Gatton ..	20, 21 and 22
Redlands ..	21 and 22
Tully ..	21 and 22
Woodford ..	21 and 22
Atherton ..	25 and 26
Innisfail ..	28 and 29
Lawnton ..	28 and 29

August.	
Brisbane ..	5 to 12
Redcliffe ..	18 and 19

September.	
Canungra ..	2
Beenleigh ..	15 and 16

—◆—

TUBERCULOSIS-FREE CATTLE HERDS (AS AT 13th MARCH, 1950).

Breed.	Owner's Name and Address of Stud.
Aberdeen Angus	The Scottish Australian Company Ltd., Texas Station, Texas.
Jersey	W. E. O. Meier, "Kingsford" Stud, Rosevale, via Rosewood.
A.I.S.	F. B. Sullivan, "Fermagh," Pittsworth.
Ayrshire	L. Holmes, "Beneceula," Yarranlea.
A.I.S.	D. Sullivan, Rossvale, via Pittsworth.
A.I.S.	W. Henschell, Yarranlea.

MAY.

By W. J. NEWELL, Hon. Secretary of The Astronomical Society of Queensland.
TIMES OF SUNRISE AND SUNSET.

At Brisbane.			MINUTES LATER THAN BRISBANE AT OTHER PLACES.					
Day.	Rise.	Set.	Place.	Rise.	Set.	Place.	Rise.	Set.
	a.m.	p.m.						
1	6.13	5.17	Cairns	12	46	Longreach ..	28	42
6	6.16	5.13	Charleville	25	29	Quilpie ..	36	34
11	6.19	5.09	Cloncurry ..	38	61	Rockhampton ..	2	18
16	6.21	5.06	Cunnamulla	30	28	Roma ..	16	18
21	6.24	5.04	Dirranbandi	21	17	Townsville ..	11	38
26	6.27	5.02	Emerald ..	13	26	Winton ..	31	50
31	6.29	5.00	Hughenden	23	47	Warwick ..	5	4

TIMES OF MOONRISE AND MOONSET.

At Brisbane.			MINUTES LATER THAN BRISBANE (SOUTHERN DISTRICTS).							
Day.	Rise.	Set.	Charleville 27;		Cunnamulla 29;		Dirranbandi 19;			
			Quilpie 35;		Roma 17;		Warwick 4.			
At Brisbane.			MINUTES LATER THAN BRISBANE (CENTRAL DISTRICTS).							
Day.	Rise.	Set.	Emerald.		Longreach.		Rockhampton		Winton.	
			Rise.	Set.	Rise.	Set.	Rise.	Set.	Rise.	Set.
1	p.m.	a.m.								
2	4.26	4.43								
3	5.07	5.53								
4	5.54	7.06								
5	6.48	8.20								
6	7.48	9.31								
7	8.53	10.35								
8	10.00	11.31								
		p.m.								
8	11.04	12.18								
9	..	12.56								
	a.m.									
10	12.04	1.30								
11	1.01	2.00								
12	1.55	2.27								
13	2.48	2.54								
14	3.40	3.22								
15	4.33	3.50								
16	5.26	4.22								
17	6.22	4.59								
18	7.18	5.39								
19	8.15	6.26								
20	9.09	7.19								
21	10.00	8.15								
22	10.46	9.15								
23	11.28	10.15								
		p.m.								
24	12.05	11.16								
25	12.40	..								
	a.m.									
26	1.13	12.18								
27	1.45	1.19								
28	2.19	2.23								
29	2.57	3.29								
30	3.40	4.39								
31	4.31	5.52								
At Brisbane.			MINUTES LATER THAN BRISBANE (NORTHERN DISTRICTS).							
Day.	Rise.	Set.	Cairns.		Cloncurry.		Hughenden.		Townsville.	
			Rise.	Set.	Rise.	Set.	Rise.	Set.	Rise.	Set.
1			40	21	57	44	42	29	33	18
3			52	8	66	36	50	21	43	8
5			57	2	69	32	53	17	47	5
7			53	4	67	33	50	19	44	5
9			43	12	60	38	45	24	36	12
11			38	23	56	45	41	30	32	20
13			27	32	49	53	33	38	23	28
15			18	42	42	59	27	44	16	36
17			9	51	37	64	21	50	8	43
19			2	56	33	67	17	53	3	46
21			2	55	33	67	17	52	3	45
23			9	47	37	62	21	47	8	39
25			19	37	42	56	27	41	17	32
27			31	31	51	51	35	36	25	26
29			43	18	59	43	44	27	36	17
31			54	6	67	34	51	20	44	7

Phases of the Moon.—Full Moon, 2nd May, 3.19 p.m.; Last Quarter, 9th May, 8.32 a.m.; New Moon, 17th May, 10.54 a.m.; First Quarter, 25th May, 7.28 a.m.

On 15th May the Sun will rise and set 20 degrees north of true east and true west respectively, and on the 12th and 27th the Moon will rise and set at true east and true west.

Mercury.—An evening object at the beginning of the month when in the constellation of Taurus, it will set 50 minutes after the Sun, but on the 14th it will be in line with the Sun, after which it will pass into the morning sky and by the end of the month, in the constellation of Aries, will rise 1½ hours before Sunrise.

Venus.—Still a conspicuous object in the eastern morning sky at the beginning of the month, in the constellation of Pisces, rising 3 hours 25 minutes before the Sun and at the end of May, in the constellation of Aries, rising 3 hours 9 minutes before Sunrise.

Mars.—Now rising during the daylight hours and well up in the eastern sky by nightfall. On the 1st, in the constellation of Virgo, will set between 2 a.m. and 3.30 a.m., and at the end of the month will set an hour or two after midnight. About 11 p.m. on the 26th the Moon will pass in front of Mars.

Jupiter.—In the constellation of Capricornus, will rise about midnight during this month.

Saturn.—Not far from Mars and in the constellation of Leo. At the beginning of the month will set between 2.30 a.m. and 4 a.m., and at the end of the month will set between 1 a.m. and 2 a.m.

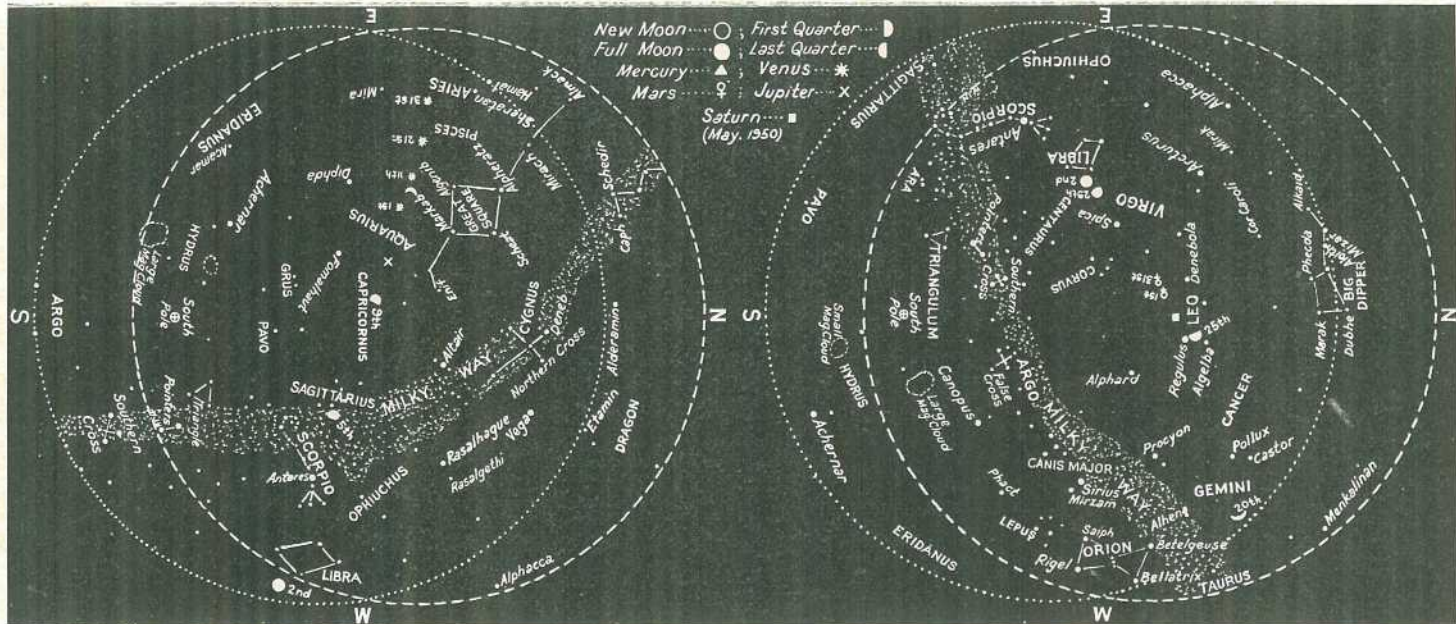

Star Chart.—The chart on the right is for 7.15 p.m. in the south-east corner of Queensland to 8.15 p.m. along the Northern Territory border on 15th May (for every degree of Longitude we go west the time increases by 4 minutes). The chart on the left is for 10 hours later. On each chart the dashed circle represents the horizon as viewed from Cape York and the dotted circle is the horizon for places along the New South Wales border. When facing north hold "N" at the bottom; when facing south hold "S" at the bottom and similarly for the other directions. Only the brightest stars are included and the more conspicuous constellations named. The stars, which do not change their relation to one another, moving east to west, arrive at any selected position about 4 minutes earlier each night. Thus, at the beginning of the month the stars will be in the positions shown about 1 hour later than the time stated for the 15th and at the end of the month about 1 hour earlier than that time. The positions of the Moon and planets, which are continually changing in relation to the stars, are shown for certain marked days. When no date is marked the position is for the middle of the month.