

*Queensland*

# AGRICULTURAL JOURNAL

JULY 1977 VOL. 103 NO. 4



# DEPARTMENT OF PRIMARY INDUSTRIES



<b>Director-General</b>	A. A. Ross
Deputy Director-General	E. O. Burns
Chief Advisory Officer (Administration)	Dr. G. I. Alexander
Assistant Under Secretary	H. J. Evans
Director, Information and Extension Training Branch	J. L. Groom
Chief Biometrician	C. P. Hamilton
Executive Officer, Research Stations Section	G. H. Allen
Executive Officer, Extension Services Board	J. Gibb

<b>Director, Division of Plant Industry</b>	B. L. Oxenham
Deputy Director	N. F. Fox
Director of Agriculture	Dr. J. K. Leslie
Director of Horticulture	H. M. Groszmann
Director, Botany Branch	Dr. R. W. Johnson
Director, Entomology Branch	T. Passlow
Director, Plant Pathology Branch	G. S. Purss
Director, Agricultural Chemistry Branch	T. J. Beckmann

<b>Director, Division of Land Utilisation</b>	J. E. Ladewig
Deputy Director	A. Hegarty
Director, Development Planning Branch	W. F. Y. Mawson
Director of Soil Conservation	H. W. Pauli

<b>Director, Division of Animal Industry</b>	L. G. Newton
Deputy Director (Research)	J. W. Ryley
Deputy Director (Field Services)	B. A. Woolcock
Director of Veterinary Services	K. M. Grant
Director, Biochemistry Branch	C. W. R. McCray
Director of Husbandry Research	L. Laws
Director of Pathology (A.R.I.)	W. T. K. Hall
Director of Sheep Husbandry	A. T. Bell
Director, Beef Cattle Husbandry Branch	M. R. E. Durand
Director, Slaughtering and Meat Inspection Branch	B. Parkinson
Director, Pig and Poultry Branch	F. N. J. Milne

<b>Director, Division of Dairying</b>	V. R. Smythe
Deputy Director	W. D. Mitchell
Director of Research	W. C. T. Major
Director of Field Services	
Director, Dairy Cattle Husbandry Branch	I. H. G. Rayner

<b>Director of Marketing</b>	D. P. Lapidge
Deputy Director	A. C. Peel
Director of Economic Services	R. B. Bygott
Director of Marketing Services	D. R. Lewis
Director of Agricultural Standards	W. V. Mungomery



*COVER: Queensland Graingrowers' Association staff, Mr. Glen Coles and Miss Jocelyn Wheeler, inspect a sunflower crop grown on Mr. George Robertson's property 'Birraklee' at Ridglands, Rockhampton. Photograph—B. Toon.*



## Contents

	page
<b>A case study in labour and fodder conservation</b> .....	290
<i>by A. J. Ernst</i>	
<b>Handling cattle</b> .....	293
<i>by M. Binstead</i>	
<b>Correas in south-eastern Queensland</b> .....	296
<i>by Beryl A. Lebler</i>	
<b>Is it really a herbicide at fault?</b> .....	300
<i>by A. C. Arvier</i>	
<b>Sharpening shearing combs and cutters</b> .....	304
<i>by R. J. Anson and W. E. M. Rothwell</i>	
<b>Production controls in the State's egg industry</b> ..	309
<i>by B. A. Berge</i>	
<b>Grain sorghum planting guide 1977-78 season</b> ..	319
<i>by Officers of Agriculture and Plant Pathology Branches</i>	
<b>Guide to grain sorghum hybrid characteristics</b> ..	324
<i>by R. G. Henzell, P. E. Mayers and O. W. Duncan</i>	
<b>The dual role of the pasture-furrow</b> .....	326
<i>by J. A. Fairbairn</i>	
<b>The spotted alfalfa aphid—a new pest of lucerne</b> ..	329
<i>by T. Passlow</i>	
<b>Big Head Disease in horses at pasture</b> .....	331
<i>By J. C. Walthall</i>	
<b>Colour grade tomatoes for higher returns</b> .....	337
<i>by R. H. Adams</i>	
<b>D.P.I. market service</b> .....	340
<b>Registered fertilizers</b> .....	341
<i>by Chemical Services Section</i>	
<b>Historical engineering relics</b> .....	387
<b>Diseases of the Heliothis caterpillar</b> .....	389
<i>by R. E. Teakle</i>	

The *Queensland Agricultural Journal* is published every second month by the Department of Primary Industries, William Street, Brisbane, Queensland, 4000. Telephone 224 0414.

Note to Editors—Articles in the *Queensland Agricultural Journal* are protected by copyright. Editors are invited to use material from the *Journal* if they acknowledge both the author and the *Queensland Agricultural Journal*.

# A case study in labour and

WALLUMBILLA district graziers, Wilson and Bill Maller, solved their haymaking problems with the purchase of a Hesston 30 Stackhand.

This was the alternative to purchasing a new, conventional haymaking plant.

Each year, Wilson and Bill conserve 300 tonnes of forage sorghum as hay off 60 hectares of crop. The hay is then fed out to cattle in 3 tonne lots. This article looks at the two methods and how suitable they are for this situation.

The details of machinery cost and usage are given in Table 1. In addition to these, the truck, tractor and labour were each valued at \$3 per hour.

The value of shelter was 1% of cost over life and the interest rate used was 11%. The

scrap values as a percentage of cost were 10% for all machines except the Mower conditioner and Stackmover which were 15%.

## THE TWO METHODS (NEGLECTING LABOUR COSTS)

### Common operation—

	\$
Mower conditioner for 75 hours ..	705.75
Tractor for 75 hours .. ..	225.00
Sub-total .. ..	930.75

### Stackhand Operation

	\$
Stackhand for 25 hours .. ..	1 216.25
Tractor for 25 hours .. ..	75.00
Stackmover for 25 hours .. ..	114.00
Tractor for 25 hours .. ..	75.00

2 411.00



Cattle feeding on a 3 tonne stack of hay in the paddock.



# fodder conservation

by A. J. ERNST,  
Beef Cattle Husbandry Branch.

Baling Operation		
		\$
Baling for 75 hours .. .. .		607.50
Tractor for 75 hours .. .. .		225.00
Twine 3c/bale .. .. .		300.00
Loading for 50 hours .. .. .		101.00
Cartage for 50 hours .. .. .		150.00
Unloading for 50 hours .. .. .		85.00
Sub Total .. .. .		2 399.25

So far, there is no appreciable difference in the cost of the two methods.

## Feeding out

Due to the layout of the property, the feed has to be carted 6.4 kilometres from the storage area to the feeding out place. Three tonnes of hay are required per feeding.

With baled hay, it takes one man 1.5 hours to load 100 bales (3 tonnes), travelling time is half an hour and feeding out takes 1 hour. This means the truck is used for half an hour (\$1.50) and one man for 3 hours (\$9.00). The cost of this operation is \$10.50. The truck was costed for the half hour it was in use because it was regarded unlikely that it would be required for any other jobs during the feeding out time.

With the stack system it takes one man for 1 hour (\$3) using the Stackmover (\$4.56) and tractor (\$3) to load, transport and feed out a stack. The cost of this operation is \$10.56.

The cost of the two methods of feeding out is the same in terms of dollars. The big advantage of the stack system is that it takes



Stacks are easily loaded and unloaded with the stackmover trailer.

1 hour whereas the bale method takes 3 hours. A similar saving in labour hours occurs with the stack system from harvest to storage.

	SYSTEM			
	Stack		Bale	
	Hrs.	\$	Hrs.	\$
Labour required for:—				
Mowing and conditioning crop .. .. .	75	225	75	225
Baling or stacking .. .. .	25	75	75	225
Loading, cartage, unloading .. .. .	25	75	150	450
Total .. .. .	125	375	300	900

### Which is the better system?

We have seen how the two systems compare. The machinery operating costs for this job are similar. However, if we look at the labour hours involved, the stack system comes out way ahead.

	Stack	Bale
Labour hours from harvest to storage .. .. .	125	300
Labour hours from storage to feed .. .. .	100	300
Total .. .. .	225	600

The biggest advantage of the stack system is it can be carried out by one man. It saves 375 man hours compared to bales.

If some of the saved time was used to do contract work with the stackhand, the operating costs per hour would be further reduced.

### What are the real costs?

REAL COSTS (INCLUDES LABOUR AND MACHINERY)

	Stack	Bale
	\$	\$
Cost from harvest to storage	2 786	3 300
Cost per 3 tonne equivalent to storage .. .. .	27.86	33
Cost feeding out 3 tonne equivalent .. .. .	10.56	10.50
Cost per 3 tonne equivalent harvest to feeding .. .. .	38.42	43.50

In this project, no allowance has been made for a hay shed. This would have increased the cost of the bale operation. The stackhand system is designed to leave the stacks out in the open. However, at this stage we are unaware of differences in the feeding values of hay from the different systems due to deterioration in the stacks. This may alter the situation and favour the bales operation but only time will tell.

The final result is that the stack system not only saves a lot of time but when everything is considered it is \$5 cheaper per feeding. Over the whole of Wilson and Bill's job this means a saving of \$500 plus 375 hours of work.

TABLE 1  
MACHINERY COSTS AND USAGE DATA

Machine	Mower Conditioner	Hay Baler	Bale Loader	Bale Elevator	Heston 30 Stackhand	Stack Mover
Price (\$)	4 700	5 000	810	680	13 900	3 910
Life (Hrs)	2 000	2 500	1 200	1 200	2 500	2 500
Annual Usage (Hrs)*	75	75	50	50	25	125
Repairs Maintenance†	120	80	40	40	80	60
Cost \$/hr						
Repair and Maintenance ..	2.82	1.60	0.27	0.23	4.45	0.94
Depreciation‡	2.00	1.80	0.61	0.51	5.00	1.33
Shelter .. .. .	0.63	0.67	0.16	0.14	5.56	0.31
Interest .. .. .	3.96	4.03	0.98	0.82	33.64	1.98
Total .. .. .	9.41	8.10	2.02	1.70	48.65	4.56

\* hrs of use for jobs were supplied by producer

† % age of cost of machine over its life

‡ depreciation =  $\frac{\text{cost } \$ - \text{Scrap Value } \$}{\text{life in hrs}}$



# Handling cattle

by M. BINSTED,  
*'Glenidol', Rolleston.*

AT 'Glenidol' we handle a large number of fattening cattle of every breed, creed, and colour.

We buy most of our store cattle from almost anywhere in Queensland, and sell fats at all centres from Rockhampton to Brisbane. One of our major aims at 'Glenidol' is to minimize the problem of bruising and we do believe we obtain a premium price for our fat cattle because we deliver the goods with an absolute minimum of bruising.

I believe that the grazier is responsible for the bulk of the bruising, in that he is responsible if his cattle are not worked or transported correctly.

The figures available to me demonstrate that the loss to the cattle industry through bruising alone is in the vicinity of \$17 to \$19 million a year. That represents a loss of something like \$5 to \$6 a head.

This article was part of a series of addresses presented at the Carcass Appraisal and Meat Preparation Symposium of the Tropical Grassland Society. The symposium was organized by officers of the Department of Primary Industries and interested producers.

## The weaner

The place to start is with the weaner. This is the most important part of a beast's life, because the attention and handling he receives at this time will reflect in him for the rest of his life.

Most weaning and feeding is done in the yard today, and this is important because it gives the cattle confidence in the handler. But it seems to me that not enough weaners are actually worked through the yards, particularly through the pound. They should be worked quietly and often.

After they have been in the yard several days and have settled down they should be taken out, driven around, taught to 'block-up' and 'feed-out'.

Trucking weaners is one method of educating cattle to transport in later life. Graziers who have the facilities to move weaners in a truck should do so in order to save bruising costs at a later date.

Many people do not put this sort of work into weaners because it does not make any money but I believe bruising to be a direct financial loss which the industry cannot afford.

## Dehorning

A well-presented line of dehorned cattle will attract a better price from me—as a store buyer—than the same cattle with horns.

The only time that cattle should be dehorned is at branding. Unfortunately, because this is not commonly adopted, we are forced to buy horned cattle and tip at 20 to 24 months. At that age, I think that dehorning is far too severe on a beast although I accept that tipping is not as effective in avoiding bruising.

## Mustering, dogs, whips and noise

The first time that an animal is mustered after weaning is a critical moment in its life. Mustering should be carried out quietly and slowly. The way cattle are mustered has a great bearing on how they work all day long.



A quiet voice is one of the greatest assets a human being has in communicating with cattle. Many of the old bullock drivers knew this; my wife tells me that I talk to the cattle more than I speak at home. Humans do not respond to being shouted at and neither do cattle.

I have never used a whip in mustering cattle, I will not allow them on 'Glenidol' and I find it hard to see a place for a whip on any property. I also discourage the use of floggers—they make too much noise, and jiggers are completely banned. Jiggers stir cattle too much, and are a direct cause of bruising in loading.

Well controlled dogs can have a place in working younger cattle, but they should never be used with fattening cattle. Unfortunately, one rarely sees a well-controlled dog. Dogs should never be allowed to work in yards, their main ability being to teach cattle to kick.

## Yards

If yards are already on the property, there is little that can be done but make do with them short of complete rebuilding.

One of the mistakes made by selectors building yards has been to build from patterns from some of the old stations of the past. These yards were an ideal type of complex for handling a large number of cattle, but they became very impractical when brought down in scale to suit a small property.

Too many yards can create problems. You only want sufficient for the ease of handling in the space you need. Cattle need room to go into a yard and move away.

A secret in yarding cattle is to open up every gate possible to allow them as much vision and as much room as you can.

## Transport

I want to repeat here what I said at the commencement of this paper—I believe the grazier bears the responsibility for the bulk of bruising in the cattle industry.

The adoption of a pattern when loading on to transports can be very worth while. I allow no unauthorised person around the ramp. All trucks (sometimes up to 20) wait outside where they cannot be seen by the cattle. As

one pulls in to load we do not attempt to move the cattle until he has stopped. We then bring them into the pound when everyone is out of the way. No more than three men are allowed in the yard during loading. We endeavour to get the cattle to go up themselves, and if everything is quiet, they will. We have found that it is not wise to have a stranger in the yard because they will know immediately and will not work easily.

## Trucking on to rail

Most graziers fall down badly when trucking onto rail. They work the cattle from weaning and get to know how to handle them. Yet when it comes to putting them onto the train they often leave it to someone else.

Possibly the cattle will never have seen that person before, and it is in this situation that a great deal of bruising can occur. If you have gone to the trouble to bring your cattle to saleable condition ready for the meatworks, it is in your own interests to go and put them on the train as quietly as possible.

A trick I have used for many years when loading cattle onto a train is never bring them into the forcing pen until ready to load, and the race is open. If they are in the forcing yard and the train moves off, the K wagon gate crashes down and the cattle all huddle into the back of the forcing yard. They then have to be straightened out before moving up the crush. It is much easier not to bring them into the yard until they can move straight onto the wagon.

## Unloading

The last point at which the grazier has control over his cattle is during unloading.

The main bruising in transport occurs when cattle are coming off the truck, and when they all try to get off at once. This is the mistake of the people letting them off. If they are allowed to come off themselves without being rushed, the bruising problem would be minimized.

Most transport operators today are owner-drivers and it is very easy to keep a check on them. If there is any suspicion about a driver that truck can be side tracked and the kill put through separately to assess the degree of bruising. If the owner-driver has his pocket hurt, he will quickly do something about it.



## **Brahman X cattle**

Anyone who has studied sale prices in Central Queensland this year will have noticed that good, quiet cattle of any breed have commanded \$15 to \$20 a head more than temperamental types. I believe that breeders of store cattle must study the selection of a quieter, less temperamental beast even at the expense of growth rates. Hybrid vigour has been a wonderful thing for the industry but must be combined with the selection of good temperament.

The quiet beast grows better for us in the paddock, travels better and kills better and no beast achieves that result as well as a well-bred, quiet crossbred.

The basic principles of handling cattle that I have discussed are even more applicable to crossbreds. In my opinion, the Brahman is more intelligent and certainly more active than British bred cattle. To begin with, they require a different system of mustering. By keeping a man in front of the mob—working off the head—crossbreds can be walked quietly to

the yards. There is a great art in riding in the head of cattle—in judging the speed of a mob. Crossbreds will follow you anywhere if you go about the right way of leading.

We always muster crossbreds towards watering points or other spots which normally interest them. We usually take an extra man with a crossbred mob and once a pattern has been evolved—we stick to it. Brahman cattle respond well to a regular pattern or routine.

In the yards, the nervousness of Brahman X cattle means that noise is absolutely out of the question. Some crossbreds are more intelligent than humans—they can out-think us. A broken rail, a bad fence is only bad management and the crossbred is intelligent enough to take advantage of this.

I have tried to talk about a subject that is a bit of a crossbred itself—a mixture of experience, instinct and knowledge. A good cattleman works cattle with his head, thinking like a beast and above all, showing a genuine love for his cattle.

---

## **Is the brand you are using registered in YOUR name?**

- Was it transferred when your relative died?
- Was guardianship cancelled when you came of age?
- Women should notify the Registrar of Brands of change of name after marriage. Did you?
- When you commenced trading as a pastoral company, did you notify the Registrar of Brands?

For all your brands enquiries, contact:

The Registrar of Brands,  
Department of Primary Industries,  
William St.,  
Brisbane, Q. 4000.

# Correas

in

## South-eastern

## Queensland

by BERYL A. LEBLER, Botany Branch.

SIR Joseph Banks found the first *Correa* at Port Jackson in 1770. He named it after Joseph Correa da Serra, a Portuguese botanist, who he considered a very distinguished scientist.

Correas are shrubs which are variable in size and habit, or small trees. Stellate hairs are usually present on the outside of the flowers as well as the stems and leaves. On those parts of the plants they are often stalked and golden-brown.

The leaves are always opposite and simple. The rather large and often showy flowers are always pendulous, two or three together or solitary, terminal or in the axils of the leaves. They have four sepals, four petals and eight stamens. These are quite free and longer than the petals. The ovary has four carpels which are united at the base but spread from each other. The style stands erect from the base between the carpels.

The sepals are joined to form a cup-shaped tube which is truncated at the top, with four or eight small teeth on the margin of the cup. The petals are joined to form a tubular bell with the lobes spreading at the end.

In south-eastern Queensland the petals of *Correa* are always greenish-white or yellowish-green. In other States flowers can be found with white, yellow, orange, blue-green or green, crimson or scarlet corollas. Some are even two-toned with the spreading corolla lobes yellow or green and the tube scarlet or red.

Correas are found only in Australia. On the mainland they are confined to the southern part of South Australia, Victoria, New South Wales and south-eastern Queensland. They also grow in Tasmania.

In south-eastern Queensland there are two species—*Correa reflexa* and *C. lawrenciana* var. *glandulifera*.

### Common correa

#### *Correa reflexa*

The Latin adjective meaning bent backward sharply is the specific epithet for this plant. It describes the terminal leaves on the flowering twigs.

**DISTINGUISHING FEATURES.** The ovate leaves with cordate bases, the stellate hairs on both surfaces, and the reflexed leaves at the ends of the flowering twigs are sufficient to distinguish this plant.

**DESCRIPTION.** This is an open, branching shrub to 1.5 m. The slender terete stems are pale green with a rather bumpy appearance due to the loose covering of stalked, stellate, golden-brown hairs, some much shorter than the others. These hairs are also present on the lateral flowering branches.

The leaves are almost sessile, ovate lanceolate with a deeply cordate base and a rounded tip. They are up to 5 cm long and 4 cm broad at the base. Stellate hairs are scattered on both surfaces. The margins are not entire but are irregularly toothed, as if chewed by some insect. Stellate hairs on the margins give the leaves a ragged appearance. They are lighter in colour on the lower surfaces and the hairs on the upper surfaces make them look rough. The stem leaves spread widely from the stem and the pairs of leaves are up to 5 cm apart.



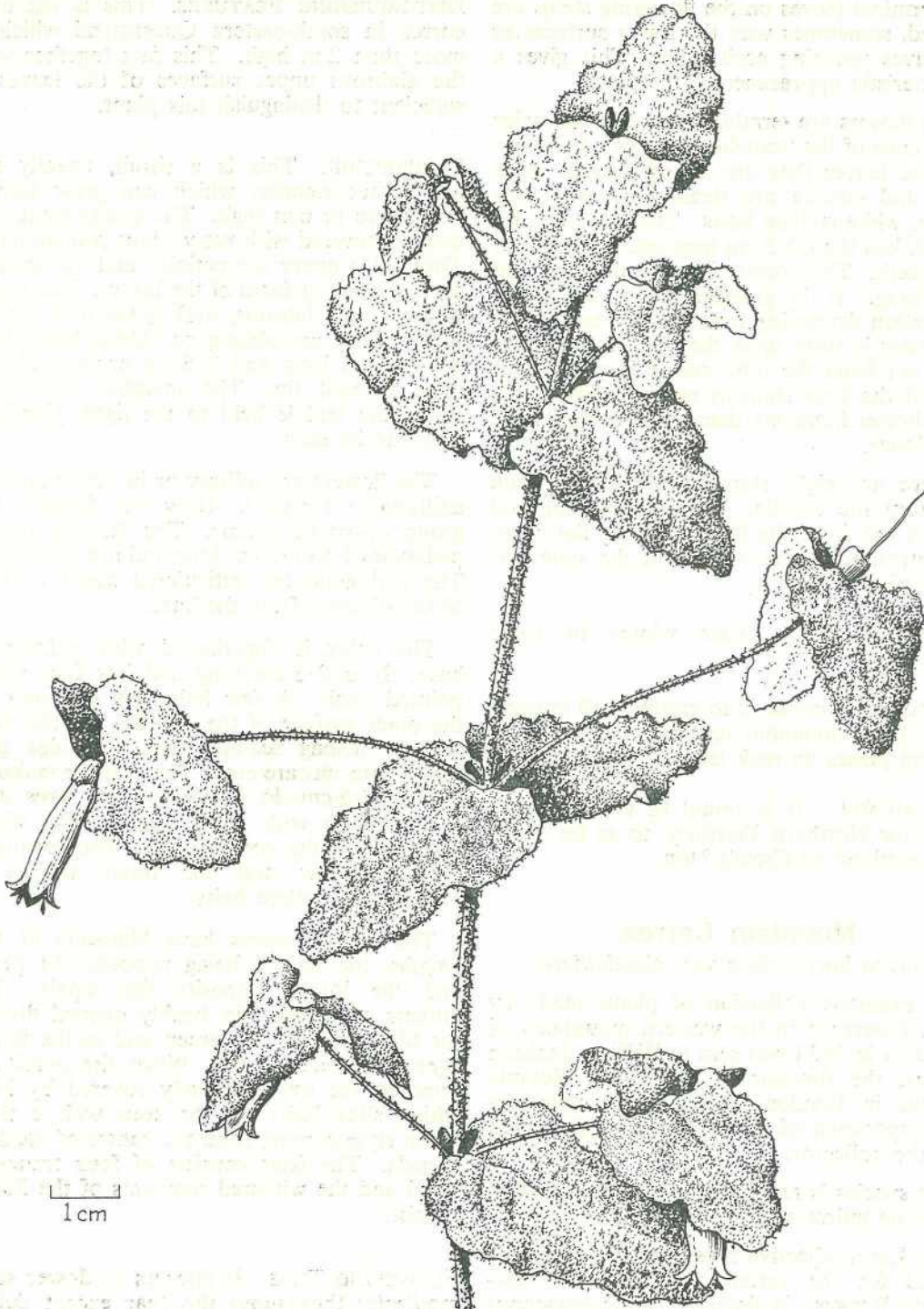

*Correa reflexa*



The terminal leaves on the flowering stems are reflexed, sometimes with the lower surfaces of the leaves touching each other. This gives a characteristic appearance to the plant.

The flowers are terminal on the lateral twigs at the ends of the branches and are pendulous. Like the leaves they are almost sessile. Both calyx and corolla are densely covered with minute, white stellate hairs. The calyx is cup-shaped, less than 0.5 cm long and ends in four short teeth. The corolla is a tubular bell and 3 cm long. It is greenish-white, the green colouration deepening towards the end. When the flower is fully open the tips of the petals curve out from the tube and it is possible to see that the four stamens opposite the petals have shorter filaments than those opposite the calyx lobes.

There are eight stamens which are quite free from the corolla. The corolla tube and stamens fall from the flower leaving the calyx tube surrounding the ovary and the style still on the plant.

**FLOWERING TIME.** Late winter to early spring.

**HABITAT.** It is confined to granitic soil in open forest. In mountainous regions it can be found in damp places on rock ledges.

**DISTRIBUTION.** It is found in all the States except the Northern Territory, to as far north in Queensland as Crow's Nest.

## Mountain Correa

*Correa lawrenciana* var. *glandulifera*

An extensive collection of plants made by R. W. Lawrence in the western mountains of Tasmania in 1834 was sent to William Jackson Hooker, the director of the Royal Botanic Gardens in London. Among this collection was a specimen of *Correa* which was named after the collector.

The species is restricted to mountain valleys and is the tallest of the *Correas*.

The Latin adjective meaning bearing glands is used for the variety found in the Macpherson Ranges. It describes the conspicuous glands in the petals.

**DISTINGUISHING FEATURES.** This is the only *correa* in south-eastern Queensland which is more than 2 m high. This fact together with the glabrous upper surfaces of the leaves is sufficient to distinguish this plant.

**DESCRIPTION.** This is a shrub, usually tall and rather slender, which can grow into a bushy tree to 6 m high. The young stems are densely covered with rusty, short stellate hairs. These also cover the petioles and are sparser on the lower surfaces of the leaves. The upper surfaces are glabrous, dark green and slightly shiny. They are oblong or oblong lanceolate, up to 7 cm long and 2.5 cm broad and end in a pointed tip. The margins are entire. When the leaf is held to the light, glandular dots can be seen.

The flowers are solitary or in threes and are axillary or terminal. Only one flower in a group opens at a time. The flowers are on peduncles 1 to 1.5 cm long and are pendulous. The peduncles are articulated about a third of the distance from the base.

The calyx is cup-shaped with a flattened base. It is 0.3 cm long and has four short, pointed teeth. A few hairs are scattered on the outer surface of the corolla, but the most striking feature is the large glandular dots which are prominent. The corolla tube is 2.5 cm long and the lobes are less than 0.5 cm long with acute pointed tips which spread from the corolla tube. The corolla is greenish-yellow and the outer surface is covered by stellate hairs.

The eight stamens have filaments of two lengths, the shorter being opposite the petals and the longer opposite the sepals. The anthers are green. In freshly opened flowers the filaments are also green and as the flower ages they become red. When the corolla is removed the ovary, densely covered by long, white, silky hairs can be seen with a thick green style coming from the centre of the four carpels. The fruit consists of four truncated cocci and the withered remnants of the flower persist.

**FLOWERING TIME.** It appears to flower spasmodically throughout the year except during the cold months of the year.



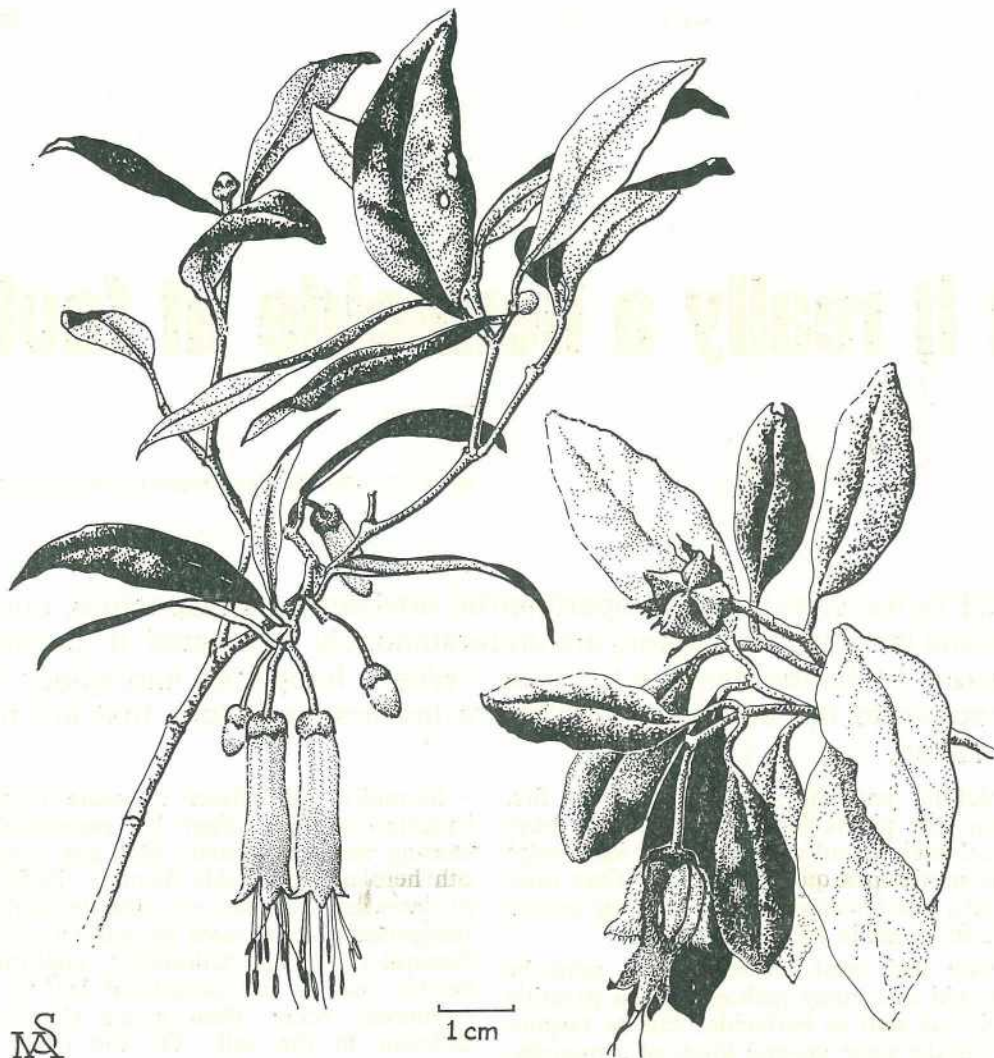

*Correa lawrenciana* var. *glandulifera*

**HABITAT.** It grows on flat somewhat swampy land, on the margins of dense rain forest, in dense eucalyptus forest and where rain forest has been cleared.

**DISTRIBUTION.** It is found only in the Macpherson Range in south-eastern Queensland near the New South Wales border.

### Field key to *Correas* in South-eastern Queensland

1. Stellate hairs present on both leaf surfaces; leaves ovate with cordate bases, those at ends of twigs reflexed . . . . . *Correa reflexa*
- Stellate hairs present only on lower surfaces of leaves, large glandular dots present in corolla . . . . . *Correa lawrenciana* var. *glandulifera*

# Is it really a herbicide at fault?

by A. C. ARVIER, *Technologist, Field Services.*

MOST farmers, as well as Departmental advisers and inspectors, consultants and insurance assessors are understandably interested in reports of apparent herbicide damage to crops. "What's happened and what's likely to happen to the affected crops?" are the first questions that are normally asked.

Naturally enough, any persons who first examine the plants for damage need to have a broad background of behavioural knowledge of the particular crop in question. They must get facts, not opinions, and must keep several points forefront in mind.

Firstly and most importantly, it must be recognised that many pathogenic and parasitic agencies as well as herbicides can be responsible for the same general kinds of symptoms. For instance, a number of plant diseases, especially some viruses and certain insect injuries such as feeding activities by red spiders, can cause twisting or mottling and other leaf abnormalities similar to those caused by phenoxyacetate herbicides.

Stunted top growth of plants infested with nematodes in the root zone can be similar to the effects of several herbicides, such as TCA and borax, that act initially upon and cause death in roots. The 'pruning' effect of such soil-active herbicides on plant roots can be very similar to the stunting action that follows nematode infestation. So misinterpretation here is quite understandable.

Secondly, the effects of some nutritional irregularities can often be responsible for causing some symptoms that are commonly confused with herbicide damage. Deficiencies of essential elements are usually fairly well recognised in most cases by unusual colouring. General yellowing ('chlorosis'), malformed or smaller leaves, and occasional leaf-tip death commonly occur when major elements are deficient in the soil. On the other hand, excessive amounts of certain nutrients, particularly some of the 'trace' elements, can cause unexpected colour changes and peculiar malformations that can be sometimes confused with the general symptoms of damage by systemic herbicides.

The obvious and spectacular symptoms of sudden wilting or desiccation naturally attract earlier attention than foliar distortion or malformation. The effects of water shortage or mechanical root damage are normally seen as the visible appearance of these symptoms, but identical responses can also follow the action of some contact herbicides, such as kerosene, paraquat or sodium chlorate.



Sometimes forgotten are temperature effects—both frosts as well as excessively high temperatures can each cause wilting, sometimes permanent, in susceptible crops; so too can extremely dry air conditions over several days, especially if combined with wind or high temperatures. Tip death of young leaves and blossom-end breakdown can often be so caused in susceptible horticultural crops such as tomatoes. Here again it is so easy for the visible symptoms of 'damage' to be confused with the results of exposure to either direct herbicide contact or accidental drift.

Sensitivity on the part of some plants towards chemical sprays not normally used on those plants should also be kept in mind. Pet preparations, tickicides and household furniture polishes and fly sprays are cases in point.

Especially objectionable are those formulations that are designed primarily for use on animals or for public health purposes. Quite often the solvents or surfactants specifically chosen for these formulations are phytotoxic and can cause defoliation, burning or spotting in the foliage of sensitive plants. Responses in the form of these abnormal symptoms can in certain circumstances be readily confused with herbicide damage.

To illustrate some abnormalities capable of causing confusion, here are three classes of crops together with visible symptoms of abnormal growth caused by various biological agencies and liable to be confused with damage caused by 2,4-D or related herbicides. The list is by no means exhaustive but it does cover many of the situations commonly met with in everyday farming situations.

#### ABNORMAL SYMPTOMS IN VERY SUSCEPTIBLE CROPS

Crops	Some abnormal symptoms which can be caused by 2,4-D	Some causal agents apart from 2,4-D which can be responsible for similar symptoms
Bananas .. .. .	Partial or complete chlorosis of young leaves Twisted terminal parts of midribs .. Generally stunted growth and dwarfed bunches with few fruit	Careless use of paraquat too close to pseudostem; arsenic residues in soil Cold and dry winter weather Insufficient water; poor nutritional status; corns infested with weevils; roots infested with nematodes
Beans (including most crop and pasture legumes)	Twisted pods .. .. . Plants collapse .. .. . Leaves turn yellow and fall off .. .. .  Apparent inability to set seed .. ..	Flowers infested with thrips Bean fly infestation; wind Reaction to rust infection and/or mite infestation; water and/or nutritional insufficiency Bean seed weevils
Cotton .. .. .	Defoliation, also drop of squares ..	Bugs and/or aphids
Cucurbits (including melons and pumpkins)	Premature shedding of flowers .. .. Chlorotic patches in foliage .. ..	Dry soil conditions Mosaic virus
Grapes .. .. .	Misshapen leaves .. .. . Shoots fail to grow properly in spring ..	Grape leaf blister mite Variety sensitive to earlier sprays of gibberellic acid
Lucerne .. .. .	Multiple shoots from crown .. .. . Premature leaf fall .. .. .	'Witches broom' virus Leaf rust; insufficient water
Pineapples .. .. .	Premature flowering in small and/or young plants	Normal increasing day length after cold, dry winter
Sunflower .. .. .	Distorted shapes in flower heads ..	Rutherglen bug infestation
Tobacco .. .. .	Incurled leaf margins and lopsided leaf shape	'Broken' emulsion of insecticide sprays
Tomato .. .. .	General lack of vigor in growth .. .. . Chlorotic foliage .. .. . Sudden wilting .. .. .	Nematode infestations in roots Mite infestation; leaf blights Vascular blockage by <i>Fusarium</i> (seen as browning in sliced stems)

MODERATELY SUSCEPTIBLE CROPS

Crops	Some of the symptoms which can be caused by 2,4-D	Other causal agents which can be responsible for similar symptoms
Beetroot .. ..	Twisting of leaves from base .. ..	Aphid infestations
Citrus .. ..	Wilted and twisted shoots and subsequent death thereof	Aphids and bronze orange bug
Clover .. ..	Incurling of leaf margins and generally erect stance of leaves	Dry soil conditions and mite infestations on the undersides of leaves
Lettuce .. ..	Twisted foliage .. ..	Bacterial disease and/or <i>septoria</i> leaf spot
Maize .. ..	Incurling of leaf margins and erect foliage	Hot, dry weather and insufficient soil moisture; 'wallaby ear' virus
Onion .. ..	Wilting of foliage .. .. Development of pale colour in foliage ..	Downy mildew Thrips infestation
Passionfruit .. ..	Dwarfing and malformations in young leaves	'Woodiness' virus
Peanut .. ..	Incurling leaf margins and erect leaves .. Premature leaf fall .. ..	Infestation of blue oat mite Leaf spot infestation
Potato .. ..	Incurling leaf margins .. .. Malformations in foliage .. ..	Early blight infection Flea beetle infestation
Sorghum .. ..	Incurling of leaf margins .. ..	Insufficient soil moisture
Soybean .. ..	Chlorotic leaves and premature defoliation Distorted pods and poor seed set .. ..	Mites Green vegetable bug
Strawberry .. ..	Abrupt cessation in flowering .. .. Deaths of buds, young flowers and stalks Abnormal fruit shape and irregular ripening Dull grey appearance of older leaves .. Reddish margins in older leaves .. .. General lack of vigour .. ..	} Cold snaps (especially in susceptible varieties, e.g., Redlands Crimson) Dry, cold winds Infestations of mites and/or nematodes Dry soil or atmosphere

RELATIVELY TOLERANT CROPS

Crops	Some of the symptoms which can be caused by 2,4-D	Other causal agents which can be responsible for similar symptoms
Sugar-Cane (Varieties Q50, Q68, Q58, Q80, and Q81 are moderately susceptible and will display classical symptoms of twisting and distortion after exposure to 2,4-D)	Mottling in leaves .. ..	Mosaic virus
	Light coloured streaks in leaves .. ..	Chlorotic streak virus
	Deaths of growing points .. ..	} Cold weather
	Chlorotic leaves (especially in bands) ..	
	Stunted and bunched foliage .. ..	Leaf hopper infestation
Tree Crops (including many ornamentals, pome and stone fruits)	Distorted leaf shapes .. ..	Various fungal diseases
	Premature leaf fall .. ..	Insufficient soil moisture

As with any biological problem, it is important to approach problems of apparently inexplicable plant damage with an open mind. All relevant factors which are accessible in the field should be examined, and this goes beyond merely noting the obviously affected plants. An investigation should embrace details of *apparent patterns* of damage, as well

as the *time* the first signs of damage were seen. Naturally enough, the *nature and position of the symptoms* on the plants should be carefully documented, and this record should include weeds and other non-crop plants in the vicinity as well as the affected crops.



If as a result of an overall inspection, exposure to contact by or drift from a herbicide is suspected, look further into the possibility of *errors in application* such as irregularities in dose rates and faults in the equipment as well as the likelihood of human errors in the techniques used. *Environmental factors* that could have operated at the time the damage was believed to have taken place should also be carefully checked; official records of wind speed and direction from the nearest aerodrome or weather bureau can be particularly useful in this context.

Here is an eight point check list to follow when investigating any allegation or suspicion of damage to plants which has been said to be due to herbicidal application:—

1. Study closely the leaves, growing points, buds, flowers and young fruit; hold the young leaves up to the light and check for vein-clearing against leaves of similar age from normal plants.
2. Carefully dig some plants and examine the roots for abnormalities; do not rely solely on an inspection of the top growth.
3. Use a hand lens for checking the presence of mites and small insects, as well as a pocket knife for slicing stems and roots to reveal any discolorations in the vascular systems.
4. Check for any patterns of damage in the area; look around and ask questions among the neighbours.

5. Enquire closely the date the symptoms were first noticed, as well as when the symptoms appeared relative to the normal farming operations. (e.g. three weeks after seedling emergence, one week after nitrogen side-dressing in the shot-blade stage, etc.)
6. Record the nature of the visible symptoms, as well as their position on the plant.
7. As well as the affected specific crop plants, look at weeds on fence lines, headlands and interspaces as well as any other plants such as vegetable gardens and ornamentals, in the vicinity.
8. If a herbicide has been used in the vicinity, and some unexpected movement of the herbicide appears to have taken place, check for possible application or operator errors; e.g. the dose actually used, the calibration and efficiency of the application equipment, and the particular technique of application.

Finally it is appropriate to mention that the Department of Primary Industries can investigate a complaint of alleged damage under the provisions of the *Agricultural Chemicals Distribution Control Act 1966-1972*, if it appears that the damage could have been caused by a commercial operator working on land he did not own. In such an event and acting upon receipt of a Notification on Complaint of Damage (Form 10), a Departmental Inspector would carry out the abovementioned procedure, including in all probability the taking of adequate plant samples for residue analysis purposes.



# Sharpening Shearing Combs and Cutters

by R. J. ANSON and W. E. M. ROTHWELL,  
*Sheep and Wool Branch.*

EVERY shearer knows the sound of well-ground combs and cutters. It's sweet music, that means more sheep shorn and allows for good, clean work and a better 'cut' of the wool.

Bad grinding contributes to excessive wear of combs and cutters, faulty shearing of sheep, and handicaps good shearers.

There are two types of grinders, the most common being the disc grinder, and the other the vertically mounted endless belt grinder. Both makes may be electrically or belt driven.

This article concentrates on the disc grinder and is intended to convey hints on how to achieve the best from the machine.

## The disc grinder

The disc grinder is made either as a single grinder or double ended grinder. If it is a belt-driven machine, it should be run at a speed of between 2 400 and 3 000 r.p.m. Electric grinders turn at 2 850 r.p.m. A revolution counter or tachometer is necessary to check these speeds, as some small, portable plants often turn too slowly for effective grinding.

The grinder consists of the housing, grinding discs, supporting arms, and pendulum. All should be correctly adjusted for good grinding.

Combs and cutters are sharpened on an accurately machined, convex shaped grinding disc onto which a twill backed emery 'lap' (a single sheet of emery cloth) is glued.

Coarse emery paper (No. 40 grit) is used for combs, and fine emery paper (No. 80 grit) for cutters. Heavy-duty carborundum gives a better cutting edge to the tools, and lasts much longer than emery of a cheaper quality.

## Preparation of the grinding discs

The removal of used emery 'laps' from a disc is done by soaking the disc in clean warm water. The disc face is cleaned by a bristle brush and hot water. NEVER USE a steel brush or emery paper as these rub off circular ridges that hold the glue.

When washed clean of old glue, rinse the disc in clean water and allow it to dry. After the disc is dry cover it evenly with glue using a small brush, making sure the glue does not get down into the centre recess of the disc.

Emery laps can be purchased with centre holes to take the stud of the clamp-plate. If not, a hole is made in the centre by the use of a piece of 25.4 mm (1") pipe which has been sharpened to an edge. Cutting out should be made with the emery resting on a piece of wood.

The emery lap is fitted to the clamp, and the disc placed onto the clamp and rotated once to remove all air bubbles and to even out the glue before the disc is tightened down.



The emery lap is clamped overnight. If this cannot be done it must be clamped for at least 4 hours. Before removing the emery disc from the clamp, the excess emery protruding must be cut away from the disc edge. The trimming must be close and neat along the edge of the disc. Poorly trimmed laps will eventually lift away from the disc in use. When trimming, always use a sharp knife and cut towards the disc so that the lap is not pulled loose at the edge.

Finally use a sharp, pointed knife to cut away the emery from the recess in the centre of the disc. Do not cut the emery away by tapping around the inside edge of the disc with a ball head hammer as this method will soon upset the balance of the disc.

### Grinding procedure

The grinder is a dangerous piece of machinery and care should be taken while it is being used. It should never be left **unattended** while the discs are in motion. Care should be taken to see that the grinder is being driven in the correct direction, as the spindle has a left and right handed thread at each end. This is to ensure that the lock-nuts will tighten against the turn of the disc.

Assuming that a double-ended disc grinder is being used, and the emery discs are ready for use, proceed as follows, remembering that the following points are the most important to observe in relation to the whole grinding exercise and whether the ensuing work done is bad or good.

### Indications of bad grinding

- Comb or cutter ground too much to the heel.
- Comb or cutter ground towards the tips of the teeth.
- Comb or cutter ground to one side.
- Grinding marks running across the cutting surface of the teeth.
- Feathered cutting edges.
- Burnt combs or cutters.

All these are attributed to three operating faults and in some cases inexperience on the part of the person carrying out the work. The three operating faults are:

1. Incorrect setting of the pendulum.

2. Grinder turning at too low a speed.
3. Worn emery lap.

### Indications of good grinding

- A good cutting edge on both comb and cutter.
- An even and level surface on both comb and cutter.
- A 'hollow grind' in the correct place.
- A 'heel grind' of the required depth.

These attributes can only be achieved by correct setting of the pendulum.

### Setting the pendulum

Before setting the pendulum, three points are important to consider:

1. The vertical position of the pendulum.
2. The location of the magnetic-holder bottom pole relative to the horizontal line of the disc.
3. The distance out from the face of the disc of the magnetic holder with comb or cutter being held at the 'point of balance'.

It is helpful to understand the basic principle of the term 'point of balance'. The lower pole of the magnetic-holder lies ahead of the top pole by 0.8 mm ( $\frac{1}{32}$ " ) and is 6.35 mm ( $\frac{1}{4}$ " ) above the magnetic-holder pins, so that when the comb is on the disc, being ground, only the bottom pole is in contact with the comb. This point of contact is the 'point of balance'.

This setting of the lower pole allows the points of the comb or cutter to be held away from the grinding disc until the last moment, and to be taken from the disc first, protecting the points and giving a heel grind. The line of balance changes slightly with successive grinds of the tools and it becomes difficult to maintain the heel grind. Provided the pendulum is set up correctly in the following manner, good grinding will result until the tools have outlived their working usefulness for shearing.

### The pendulum setting

The correct setting of the magnetic-holder with comb or cutter on is illustrated in Figure 1, Figure 2 and Figure 3.

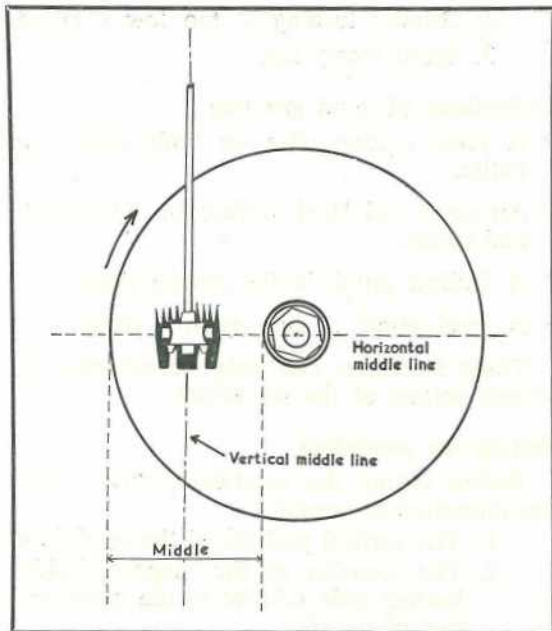

Figure 1: Adjusting the pendulum. Note the position of the comb.

To obtain these settings, place the pendulum rod on the hook of the supporting arm or standard, place a comb on the magnetic-holder pins making sure they are adjusted in keeping with the thickness of the comb. They must not protrude through the pin holes of the comb. Then carry out the following procedure.

- Ease the lock nuts of the supporting arm at its base in the grinder housing, and swing it across the face of the emery disc until the vertical centre of the comb corresponds with the vertical middle line of the disc surface midway between the edge of the recess in the middle of the disc and outer edge (Figure 1).
- Raise or lower the supporting arm until the bottom pole of the magnetic-holder is in line with the horizontal middle line (Figure 1).
- Next adjust the supporting arm so that the pendulum when hanging vertically swings clear of the disc by about 12.7 mm ( $\frac{1}{2}$ " or a matchbox thickness) and the heel of the comb just touches the face of the disc (Figure 2).

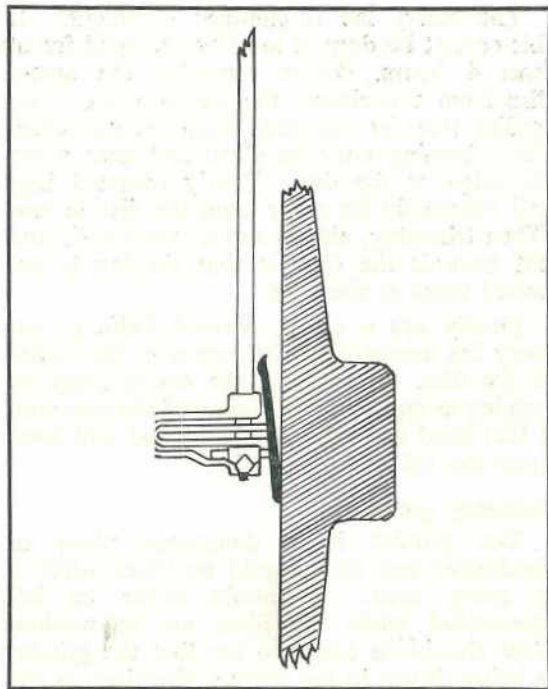

Figure 2: The heel of the comb must just touch the disc, with the tips of the teeth pointing slightly away from the disc.

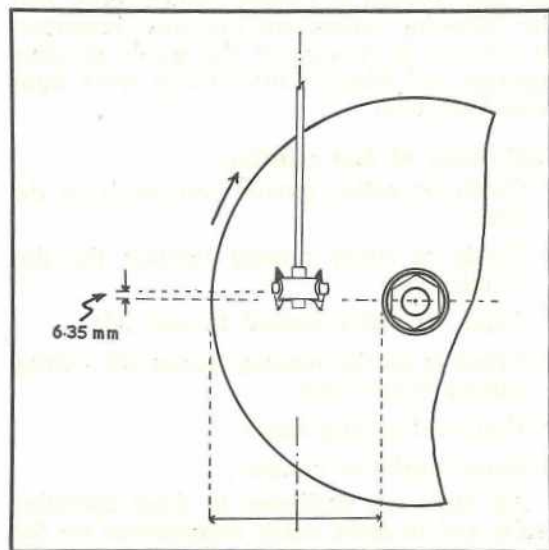

Figure 3: For sharpening cutters the lower pole of the magnetic holder must be 6.35 mm ( $\frac{1}{4}$ " ) above the horizontal centre line.



- After these adjustments are made the lock nuts are tightened, and if a double ended grinder is being used the other side is adjusted similarly.

- To make sure the pendulum is set correctly the above points should be checked again.

For sharpening cutters the magnetic-holder should be set higher by screwing the pendulum rod 6.35 mm ( $\frac{1}{4}$ " ) deeper into the holder, so that the lower pole of the magnetic-holder is 6.35 mm or ( $\frac{1}{4}$ " ) above the horizontal centre line (Figure 3).

On some pendulums the rod may not have enough thread to allow this setting to be achieved, therefore it is best at the beginning of the procedure to screw the pendulum rod tightly into the magnetic holder and then unscrew it 6.35 mm ( $\frac{1}{4}$ " ) and work through the adjustment of the supporting arms as stated.

### How to grind

First of all, combs and cutters should be cleaned thoroughly. The best way to clean combs and cutters is to wash them in hot water and detergent. The pin holes and recesses on combs and cutters must be thoroughly clean, and tools completely dry before grinding commences.

When grinding on the left face of the grinding disc the operator should stand firmly before the grinder with the right foot slightly forward for balance. Fit the comb or cutter over the pins on the magnetic-holder and hold the swivel yoke between thumb and forefinger of each hand. The swivel yoke must be held **NOT THE MAGNETIC-HOLDER.**

- Start the grinding with the pendulum rod vertical. Push the magnetic-holder with comb or cutter fitted over the pins, firmly and squarely on the disc.
- Move the pendulum to the centre of the disc, then work it slowly to the left and then to the right (with the arms not the wrist). Use the whole disc surface.
- **MOST IMPORTANT POINT TO NOTE WHILE GRINDING IS THAT THE SPARKS FLY STRAIGHT UPWARD. THIS INDICATES THAT THE GRINDING MACHINE IS CORRECTLY SET.**

- Pressure on the comb or cutter should be firm but not excessive while it is moved to and fro across the surface of the grinding disc. The comb or cutter should move to the inside and outside edges of the grinding disc so the grinding surface will be worn uniformly.

- Press more heavily on the inside of the disc for an even grind, as the outer edge turns faster than the inner. Be careful of the centre nut when grinding near the inner edge.

- Finish the grinding with the pendulum rod in a vertical position.

- The operation should take 5 or 6 seconds.

### Sharpening

To determine whether a comb or cutter is sharp the cutting edges should be examined in good light. A blunt edge is indicated by a thin, clearly visible line along the cutting edge. Grind the comb or cutter until all these bright shiny lines have vanished.

After a new surface has been ground all over the comb or cutter, take it to the middle of the grinding face and give a firm push to sharpen it. Then pull it straight off the disc. This part of the disc is slightly convex and will give the comb a hollow-ground effect which reduces friction in cutting.

### What to observe when grinding

- Examine combs and cutters in a good light during grinding.
- Care should be taken to see that the tools do not become overheated. This is indicated by a blue discolouration. Heavy pressure during grinding causes feather edges, and burnt combs and cutters become soft in the steel and will not retain a cutting edge.
- Only light pressure should be applied to the comb or cutter while sharpening when the emery cloth is still new. As the emery becomes worn pressure should gradually be increased. Once an emery has to be 'livened up' by drawing a worn out comb across its face it should be discarded.



- Combs should never be left on longer than 5 or 6 seconds at a time. If a comb or cutter requires excessive grinding it is advisable to allow it to cool off at intervals.
- More pressure is needed for combs than cutters.
- Combs should be ground by pressing downward slightly on the pendulum base. This gives a good heel grind. A worn out comb should be very thin at the heel, but still have a trace of bevel on the points. If this is achieved then it has been well ground.
- A heel ground cutter should have a distinct taper on it when the heel is worn away. Point ground cutters often drag and prick the skin of the sheep. Properly ground cutters retain their wide 'throw', give a better cut, and are more likely to match on the teeth of the comb and not drag off the wool.

#### Care after shearing

- Remove the grinding discs from the machine. Bolt one of the discs to the clamping plate and store the other one in a bag in a dry place to prevent the emery cloth from lifting.
- If emerys are worn they should be removed, the discs thoroughly cleaned and dried, coated with a thin layer of grease and stored in a dry place.
- Place an iron cap over the poles of the magnetic pendulum and store in a safe place. A nail or bale fastener will do. Without this 'bridge' magnets will become weakened in time.

EDITOR'S NOTE—Both authors are technically qualified in sheep shearing experting.

## D.P.I. releases new wheat variety

A new Prime Hard wheat variety, Cook, has been released to the grain industry by the Queensland Department of Primary Industries.

The release was announced last month by the Minister for Primary Industries, Mr. V. B. Sullivan.

Cook, named after Captain James Cook, was developed at the Queensland Wheat Research Institute in Toowoomba by Drs. J. Syme and R. Rees and Mr. D. Law from crosses of the Timgalen and Condor varieties.

Previously, it was numbered UQ7401A. Limited seed supplies have been distributed by the State Wheat Board and ample stocks for all growers will be available next year.

Cook is a quick-maturing variety which combines disease resistance with high yield and excellent grain quality. Milling quality at least was equal to that of the previous best variety, Spica, and good dough strength would make it attractive in Prime Hard export markets. Test weight was very high and the small, plump grain had some resistance to weathering.

The grain yield of Cook was superior to all other Prime Hard varieties of quick maturity in 37 trials conducted by the Department during 1975-76.

Cook is resistant to present races of stem rust, to flag smut and has a good level of resistance to crown rot. But it is moderately susceptible to leaf rust. In its growth habit, Cook tillers vigorously and, because of this and its small seed size, low planting rates, similar to those used for Timgalen, are recommended.

The leaves are very narrow, giving a weak appearance to early growth. The straw is fine and, although semi-dwarf in height, it is moderately susceptible to lodging.

The variety comes to head slightly later than Timgalen, and the ears are fully awned, white-chaffed and free-threshing.



# Production controls in the State's egg industry

THE scheme to limit egg production in Queensland will be officially 4 years old in September, 1977.

Although the Hen Quotas Act was proclaimed in September, 1973, more than 27 years elapsed before the administrative difficulties of implementing the scheme were resolved.

The scheme has transformed the egg industry in Queensland. The principles of its operation, if modified, may be useful in other industries where over supply problems occur.

To fully appreciate the application of production controls in the State's egg industry, it is necessary to understand the industry's structure and a history of the over supply problem.

## Structure of the Industry

Although the egg industry in Australia is structured on a State basis there are important national linkages which influence the total marketing and financial situation of the industry.

The industry structure in Queensland is unique by national standards in that Queensland is the only State where the one Board does not have jurisdiction over the whole State.

by B. A. BERGE,  
Marketing Services Branch.

The complexity of the structure can best be explained by reference to the flow chart which illustrates the way in which eggs are marketed from the production units throughout the State.

## Production flow

There are two distinct Board areas in Queensland—south Queensland (SQ) and central Queensland (CQ).

The Egg Marketing Board (E.M.B.) was established in 1923 and has jurisdiction over egg marketing in a certain defined area of south Queensland. The Central Queensland Egg Marketing Board (C.Q.E.M.B.) was established in 1947 and covers a certain, defined area of central Queensland. No board operates in other areas of the State. However, the industry outside the board areas is confined almost entirely to north Queensland.

In the Board areas, growers holding 50 or more domesticated fowls are obliged under the Primary Producers' Organisation and Marketing Act to market their eggs through the appropriate board. Although the Act requires these growers to market their eggs through their Boards, the Boards do permit growers, under certain conditions, to sell eggs direct to the public. Hence, the appearance of permit sales on the flow chart.

In the Board areas, eggs which are received by the Board are graded, packed and then sold on the local market in the particular area concerned. Production in south Queensland and central Queensland exceeds local demand while production in the non-Board areas is not sufficient to meet the local needs. Eggs surplus to south and central Queensland local requirements are sold in the non-Board areas of Queensland and in the Northern Territory through a body called the Queensland Egg Boards' Co-ordinating Committee (Q.E.B.C.C.)

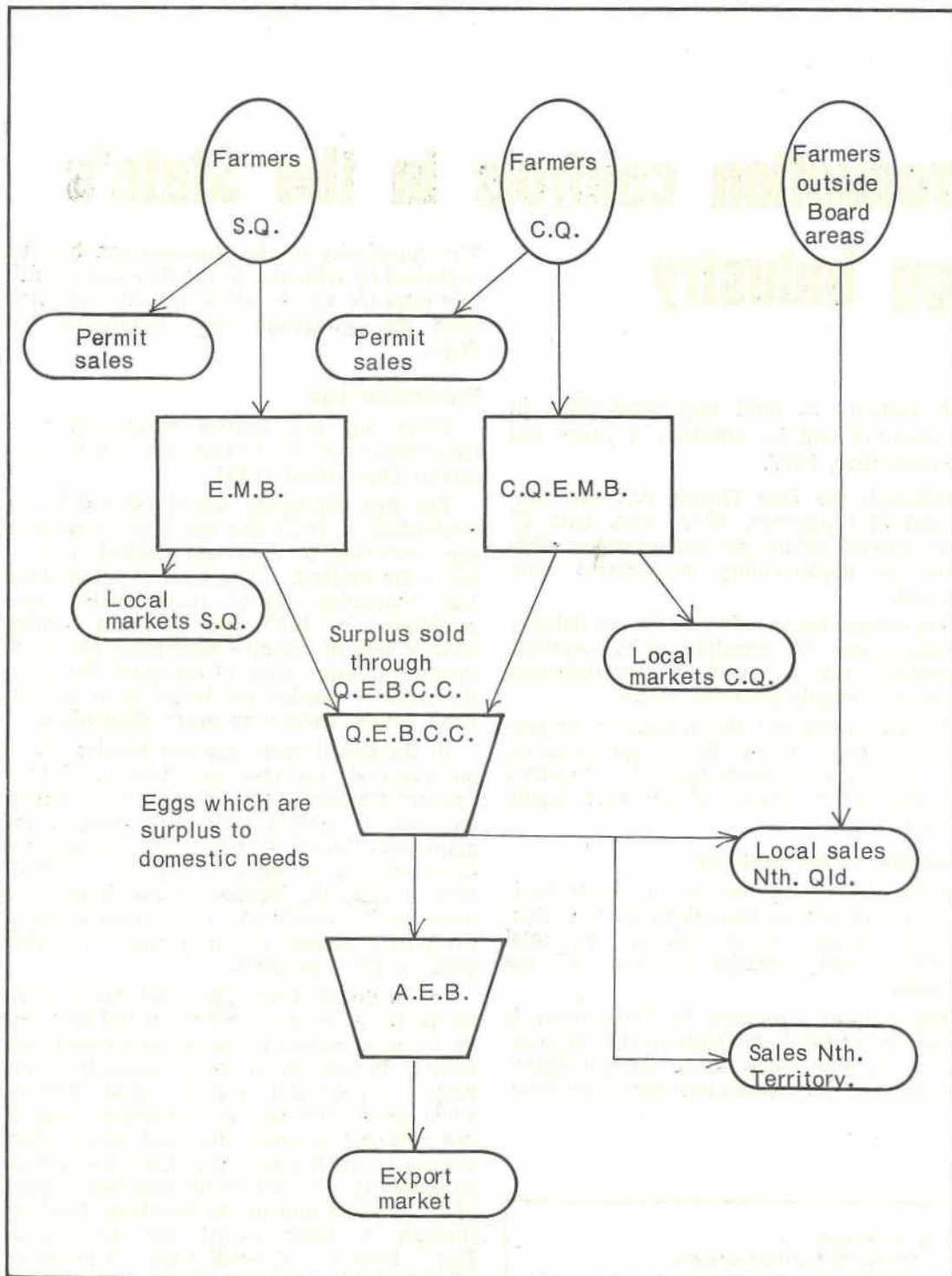

Production flow chart.



The Q.E.B.C.C. does not physically handle eggs, but is an administrative and co-ordinating body. The Committee was formed under an agreement between the two Boards in order to rationalize sales by the Boards in the outer areas, and to preclude the destabilizing effect of the Boards competing with each other in these areas.

In addition to sales in the non-Board areas in the Northern Territory, surplus eggs are exported on the world market. These eggs are exported through the Australian Egg Board (A.E.B.) which is also an administrative body, co-ordinating Australian exports. The Australian Egg Board does not physically handle exported eggs.

Growers who so desire may sell some or all of their eggs interstate and, under the Australian Constitution, thereby operate quite legally outside the jurisdiction of the Boards.

### **Income flow**

The income flow for egg producers is simply the reverse of the production flow with a few minor, but important, modifications. Egg producers throughout Australia must, under Commonwealth legislation, pay hen levy on all hens 6 months of age and over which are kept for commercial purposes, excluding the first 20 hens in any flock.

The money is collected by the Boards in the various States—The Egg Marketing Board in Queensland—and is paid into the Poultry Industry Trust Fund of the Commonwealth Government. The Commonwealth Government pays an equivalent amount to the Council of Egg Marketing Authorities of Australia. (C.E.M.A.A.)

The money is returned to the State Boards through the C.E.M.A.A. and is used to offset the losses which the Boards incur on eggs which are exported. Payments to Queensland come to the Boards via the Queensland Egg Boards' Co-ordinating Committee. This round-about way of collecting and distributing the levy funds is necessary to satisfy certain Australian Constitutional requirements. Under the Constitution, States cannot legally impose such levies.

Those States which export most eggs, and thus incur most losses, receive the greatest proportion of the money from the fund. The

scheme was established under Commonwealth legislation in 1965 at the request of the industry during a period of gross over-production in Australia.

It was designed as a form of insurance against State Boards yielding to the temptation to sell their excess eggs in neighbouring States, rather than suffer the losses which are incurred on exporting eggs. The scheme was also seen as a means of forcing growers selling interstate—they also contribute to surplus production—to shoulder some of the industry losses on eggs exported, either as pulp or in shell. The C.E.M.A.A. agreed recently that each State be returned a minimum of 70% of its hen levy collections.

Growers supplying the Boards pay charges for administration, handling and grading.

Receipts from exported eggs go to the Boards via the A.E.B., C.E.M.A.A. and the Q.E.B.C.C. Thus, grower income in the Board areas comes from four sources. These are:

- (i) Sales by the Boards on the local markets.
- (ii) Sales by the Q.E.B.C.C. in the non-Board areas of the State and in the Northern Territory.
- (iii) Export returns from the A.E.B.
- (iv) Reimbursement of levy from the C.E.M.A.A.

Returns to Board suppliers will change with changes in any of the above, and also with changes in the proportion of production exported.

The income of growers in the non-Board areas comes directly from local sales.

### **History of the over supply problem**

Throughout the 1960s and early 1970s, over-production of eggs in Australia threatened to cripple the industry financially. Surplus egg pulp at the end of June 1972 was approximately 18 000 tonnes, equivalent to nearly two years' export clearance. However, the stockpile did not peak at that level. In 1974-75, the exportable surplus climbed to a final total of 24 040 tonnes of egg pulp equivalent.

The cost of holding such stockpiles in cold storage was a major financial burden on the industry. Apart from this, the industry was sustaining a loss on those surplus eggs which were actually being sold. The return on



exported pulp was not sufficient to cover the cost of receiving, handling, pulping, transporting and storing surplus eggs.

The situation generated considerable pressure for reform. The industry appeared to have two alternatives open to it:

- (i) Adopt a *laissez faire* approach in the hope that things would sort themselves out in the long-run, whatever the cost to producers; or
- (ii) implement some form of demand/supply management scheme which would result in production being geared more realistically to available markets.

Throughout 1971 and 1972, meetings were held between industry leaders and State and Commonwealth Government representatives, both Ministerial and Departmental, to discuss the question of implementing production controls.

Agreement was reached in September 1972 that production controls be implemented. In October 1972, a determination was made as to the size of the national quota and its distribution among the States. The national quota currently is 13.3 million hens of which Queensland's share is 1.9 million.

The legislative embodiment of the scheme in Queensland is the Hen Quotas Act which was introduced in 1973. It was proclaimed in September of that year following a poll of growers.

The Act establishes a Hen Quota Committee whose responsibility it is to allocate individual quotas to the State's egg producers.

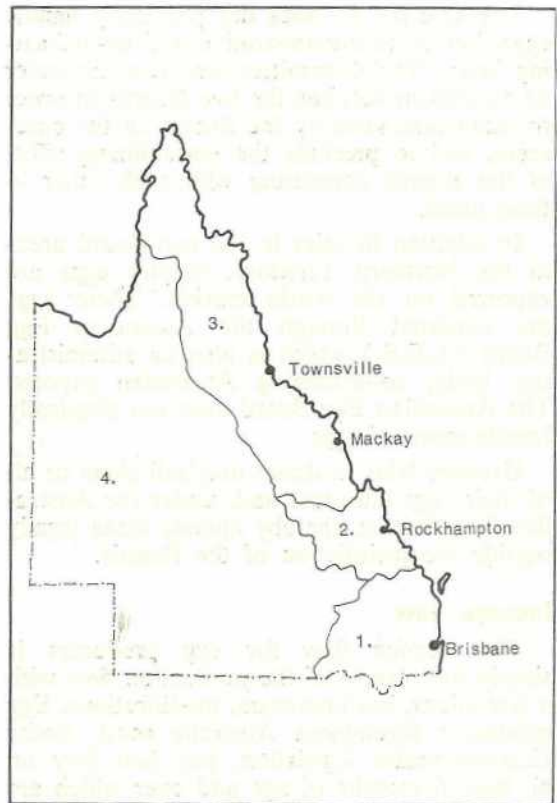

Queensland quota districts.

The Act also establishes an Appeals Tribunal to adjudicate on appeals by growers who are dissatisfied with the Committee's decisions.

For quota administration purposes, the State is divided into four districts. These are:

QUEENSLAND: DISTRIBUTION OF QUOTA FLOCKS AND POPULATION THROUGHOUT THE STATE 1974 TO 1976

District	1974			1976			Actual Average Hen Holdings	
	Quota Flock (m) hens	% of State Flock	% of State Pop.	Quota Flock (m) hens	% of State Flock	% of State Pop.	1973-74 %	1976-77 (to 2-3-77) %
1	1.809	83.1	71.8	1.549	81.3	72.1	85.1	81.0
2	.145	6.7	6.7	.138	7.2	6.6	5.7	6.8
3	.211	9.7	16.6	.206	10.8	17.1	9.2	12.2
4	.012	0.6	4.9	.013	0.7	4.1		
Total	2.178	100.0	100.0	1.906	100.0	100.0	100.0	100.0

NOTE.—Apparent errors are due to rounding  
(Sources: Australian Bureau of Statistics and Hen Quota Committee)



District 1. The area of jurisdiction of The Egg Marketing Board.

District 2. The area of jurisdiction of The Central Queensland Egg Marketing Board.

District 3. Certain defined areas of north Queensland.

District 4. The remainder of Queensland.

By May 1974, the Hen Quota Committee had allocated individual quotas for the whole State for the 1974-75 season.

The implementation of the scheme encouraged intensified activity by producers in the application of new technology and improved management. This caused surpluses to increase despite the limitations on flock sizes. This was a common experience in all States.

Because of this, and other factors, it became necessary in December 1975 and February 1976 to readjust quotas downward, in both south and central Queensland. There was also some natural depletion of quotas in Districts 1, 2 and 3.

The quota districts map and the distribution of quota flocks and population table show the distribution of flocks among the various districts. The table also shows a slight but discernible redistribution of flocks since 1974 more in keeping with regional population.

The redistribution of actual hen holdings from 1973 to 1977 is also shown in the table, and these demonstrate a slight but marked redistribution towards the less than self-sufficient areas of north Queensland.

### **Equalization and the return to producers**

The constitutions of The Egg Marketing Board and The Central Queensland Egg Marketing Board enable the boards to impose equalization charges on growers in order to 'make good any loss on the sale of the commodity or part thereof'.

The relationship between these equalization charges and producers' returns can best be understood by considering their application by a specific Board.

The Egg Marketing Board receives growers' eggs and disposes of them on two distinct markets. Most of the eggs received are sold on the domestic market while the remainder are pulped for export, except for a negligible proportion which are useless.

All growers delivering eggs to the Board share equitably in the proceeds of sales. Eggs sold locally attract a high return while, traditionally, eggs pulped for export realise a very low, or negative, net return after meeting processing, cold storage and freight costs.

Because the Board is virtually, though not entirely, the sole distributor of eggs produced in south-east Queensland, it is possible to identify fairly precisely the net revenue received from the marginal eggs produced in the whole region.

This enables the real net marginal return to the Board, from the output of each grower, to be analysed in a unique way. It can also be assumed that the production of each grower is disposed of on the local and export markets in the same proportion as is total production for the whole region. In other words if, for the industry as a whole, 75% of total production is sold locally and 25% pulped for export then, for practical purposes, it can be assumed that each grower's output, apart from eggs sold interstate or direct to the public on permit, is disposed of in the same proportions to local and export markets.

Generally speaking, returns from local sales and returns from overseas sales are pooled, and the producer is paid an average or equalized price. Eggs which are disposed of on the local market are sold soon after production. A considerable period may elapse, however, between the time surplus eggs are produced and when they are finally sold on the export market. This creates an administrative problem.

The Board pays its suppliers on a fortnightly basis for all deliveries. Hence, the return on surplus eggs must be actuarially estimated and paid to the Board progressively to keep it solvent. The Board is also reimbursed progressively for hen levy payments from the C.E.M.A.A.

In the past, hen levy reimbursement alone has not been sufficient to support an adequate return to producers and Boards in all States have been forced to impose equalization deductions to further support returns.

The following simple explanation of how equalization helps to support growers' returns is extracted from the January edition of the 'Sunny Queen Egg Farms Newsletter' of the Egg Marketing Board.



ALTERNATIVE (a)							
With pool deduction (equalization)							
			Doz.	Fixed Price			
Total production, say, .. .. .				1 200			
Less permit sales .. .. .				200			
= Intake .. .. .				1 000	@ 70 c =	\$700	
Less sales, say, .. .. .				700	@ .70 c =	\$490	
= Export surplus .. .. .				300	Realize say, 65c =	\$195	
						Loss	\$15
Pool deduction of $\frac{\$15}{1 200} = 1.25 \text{ c per doz.}$ , is required to equalize in this example.							

ALTERNATIVE (b)							
Without pool deduction (equalization)							
			Doz.	Fixed Price			
Total production .. .. .				1 200			
Less permit sales .. .. .				200			
= Intake .. .. .				1 000	@ 65 c =	\$650	
Less sales .. .. .				700	@ 65 c =	\$455	
= Export surplus .. .. .				300	@ 65 c =	\$195	
						Loss	Nil

Thus, with a given intake and a given export return, the use of Pool Deduction (Equalization) as in Alternative (a) above allows an increase in the local price (by 5c per doz. in this example) and an increase in the return to growers (by 3.75c per doz. in this example).

The effect of equalization and its price supporting role can also be explained diagrammatically.

Assume that OT eggs are delivered to the Board in a particular period (ignoring permit sales). Assume also that OQ are sold locally at a wholesale price of OP. After handling, grading, packing, delivery and administrative costs are deducted the net price can be assumed to be OL cents per dozen. Assume also that OX is the net return on exported eggs after all costs have been accounted for, and that QT eggs are surplus to local needs and attract the negative net price of OX when exported.

For budgetary purposes, the equalized price (OE) which the Board pays to growers must be such that the total of all equalization deductions (ELHG) equals the total loss of revenue (KJHM) from the export sale of QT eggs as opposed to the local sale of them. Since the rectangle IJHG is common to both, ELJI must equal KIGM.

A substantial portion of the losses denoted by KJHM are made good by hen levy reimbursements. Hen levy therefore represents, at once, an equalization deduction and a source of funds for offsetting losses on exported eggs. If we assume that the levy remains constant for the analysis then its influence can be ignored for rises and falls in production.

Even if an increasing proportion of eggs has to be diverted to the low priced export market, the equalized or average return to the grower can be maintained or supported through equalization deductions.

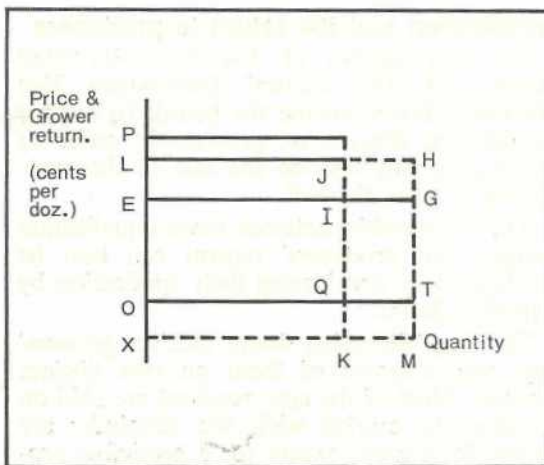

Figure 1.



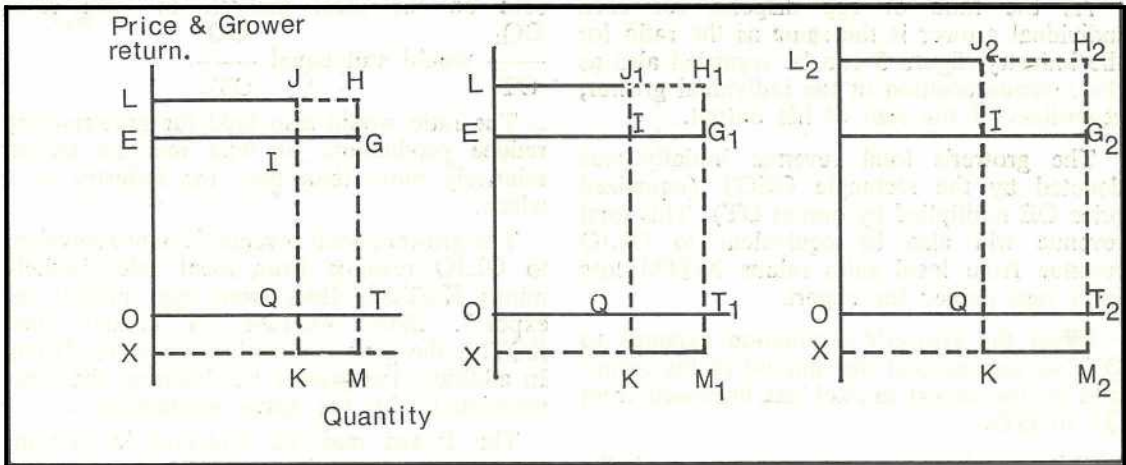

Figure 2.

As the proportion of eggs exported increases it is possible to maintain the equalized return to growers by raising the wholesale price and imposing higher equalization charges. This is demonstrated by figure 2.

High equalization charges, however, carry with them a number of undesirable features:—

- Their use is invariably associated with high retail prices. This acts to the disadvantage of consumers and to the detriment of the product itself:
- The true market value of the marginal eggs produced by the grower is hidden from him, market signals are distorted, and this leads to a build-up of market pressures which are often difficult to control.

- High equalization charges act as an incentive for growers to operate outside the Boards thus posing a threat to organized marketing.
- Their use constitutes a continuing budgetary problem which is difficult to overcome, even with the most painstaking attention to production and sales estimates.

What is the effect of the Board maintaining the local wholesale price in a situation of expanding production?

Assume that OT is total production in a certain period and that OQ of that production is sold locally at a price of OL, and that the surplus production QT is sold on the export market at the negative net return of OX.

Assume that total production subsequently increases to OT<sub>3</sub> and that at a local price of OL no more than OQ can be sold locally. This means that surplus production is now QT<sub>3</sub>. Assume for simplicity that this does not depress the net export return. Generally speaking, the increased surplus will not affect the export price, but it may affect processing and cold storage costs in a manner that would reduce the net export return.

When production expands to OT<sub>3</sub> and surplus production increases to QT<sub>3</sub>, the equalization charge EL is no longer sufficient to provide the budgetary balance referred to previously. The Board must now increase the equalization charge to E<sub>3</sub>L per dozen. This charge must be increased sufficiently to ensure that area E<sub>3</sub>LJ<sub>3</sub>I<sub>3</sub> equals exactly KI<sub>3</sub>G<sub>3</sub>M<sub>3</sub>.

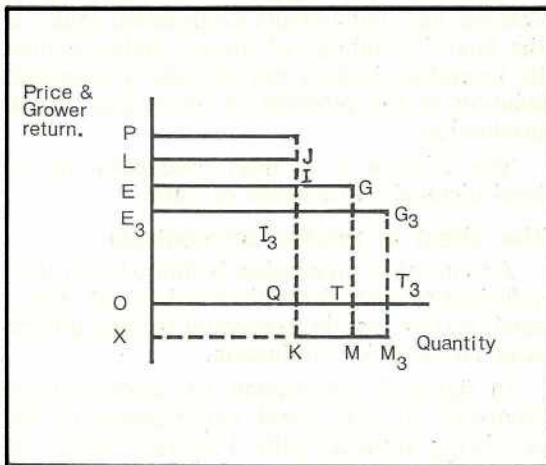

Figure 3.

As the ratio of egg disposal for each individual grower is the same as the ratio for the industry, figure 3 can be regarded also as the revenue position of the individual grower, regardless of the size of his output.

The grower's total revenue initially was denoted by the rectangle OEGT (equalized price OE multiplied by output OT). This total revenue will also be equivalent to OLJQ revenue from local sales minus KQTM loss from eggs pulped for export.

When the grower's production expands to  $OT_3$  we assume that the amount of his output sold on the export market has increased from QT to  $QT_3$ .

This could only occur, of course, if the relative expansion in this output were the same as that for the industry as a whole. Notwithstanding, the revenue effect on every grower, when industry surplus increases, will be the same regardless of whether he unilaterally increases production, maintains production or reduces production.

The only difference for growers who maintain production will be that T will remain fixed and Q will move to the left, to a point which could be called  $Q_1$ , because less is now

sold on the local market. In such cases  $\frac{OQ_1}{OT}$  would still equal  $\frac{OQ}{OT_3}$ .

The ratio would also hold for growers who reduce production, or who increase output relatively more than does the industry as a whole.

The grower's total revenue is now equivalent to OLJQ revenue from local sales initially minus  $KQT_3M_3$  (loss from eggs pulped for export). Since  $KQT_3M_3$  is greater than KQTM, the grower's total revenue has fallen. In addition, the grower has incurred the costs associated with the extra production.

The Board may be reluctant in circumstances of a general expansion of production to reduce the retail price because of the severe financial hardship such a decision would place on many growers. However, whether the Board increases the wholesale price or holds it constant it has no option but to increase equalization deductions in the face of expanding surplus production. This is potentially destabilizing for the reasons mentioned previously.

In fact, it was the recourse of Boards in all States, to the use of high equalization charges and the large scale evasion by growers that almost brought down the whole structure of organised marketing in the early 1960s. The situation eventually gave rise to the C.E.M.A.A. Hen Levy Scheme which was instituted in July 1965.

Although the C.E.M.A.A. Hen Levy Scheme has undoubtedly contributed much to the financial stability of the egg industry since its inception, it does not provide a long-term solution to the problem of increasing surplus production.

The solution is to limit production to the level dictated by domestic demand.

### The effect of production controls

Assume that production is limited to a level sufficient to meet domestic requirements plus a small service margin to account for any unforeseen shortfall in production.

In figure 4, production has been reduced from OT to  $OT_4$ , local requirements of OQ are being satisfied with a service margin of  $QT_4$  being produced.

Figure 4.

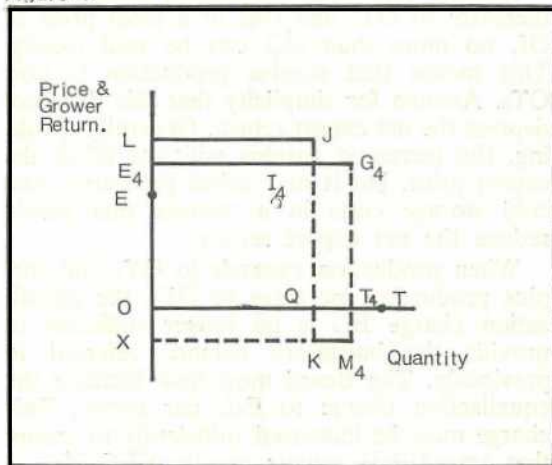





(a) The necessity for the Board to impose high equalization charges would be removed and this alone would be desirable for reasons mentioned previously.

(b) From the local consumers' point of view the scheme has the potential to eliminate price rises as have occurred in the past purely to offset the unprofitability of surplus production.

(c) The wasteful misuse of resources in producing surplus eggs is eliminated.

(d) Without raising the local price, the Board's ability to pay the grower a return more consistent with average cost of production is increased.

(e) The scheme has the potential to introduce a degree of security and stability not previously experienced in the industry.

### The rest of the State

The analysis is also relevant for central Queensland although surplus production has never been as excessive in that region.

North Queensland is not self-sufficient in eggs and the area does not come under the jurisdiction of any Board. Consequently, the analysis has limited relevance for the industry in that region.

This does not mean that the benefit of production controls is confined to the industry in the Board areas. Egg prices in north Queensland are based on south Queensland prices. The price stability which the scheme can bring to south Queensland should also be reflected in the north.

In the eyes of north Queensland, the presence of large supplies of surplus eggs in the south has, in the past, represented a threat to the northern industry. Containment of production in the southern areas will give north Queensland growers a more stable price structure and market for their product.

## KEEPING A BULL HAS ITS UPS AND DOWNS



## A.B. MAKES LIFE SO MUCH EASIER

For further information contact your nearest D.P.I. office or write to the Officer-in-Charge, Wacol A.B. Centre, Grindle Road, Wacol - Phone 372 2522. Telegrams - ARTINSEM.



# South Queensland grain sorghum planting guide 1977-78 season

by officers of Agriculture and Plant Pathology Branches

GRAIN sorghum varieties recommended for planting in south Queensland in the 1977-78 season are listed below.

In the tables, the varieties have not been ranked in order of preference.

The varieties listed 'for trial' should be sown in smaller areas for evaluation under your conditions. It would be appreciated if farmers would advise their Agricultural Extension Officer of trial plantings as this will enable a wider evaluation of the performance of these hybrids to be made.

Some hybrids appear to be closely related and are therefore interchangeable, for example Texas 626 and NK212, and Goldfinger and NK233.

The hybrid, Pioneer 846, and the open-pollinated variety Alpha show an adverse reaction to the insecticide monocrotophos.

Sorghum varieties may also exhibit a different reaction to monocrotophos at varying growth stages.

Open-headed varieties are desirable in the more humid regions.

## Planting rates

The planting rates refer to desirable established plant stands, and will be varied according to available soil moisture, time of planting and soil type. Your Agricultural Extension Officer will provide further information on planting rates.

Grain sorghum seed sold by major seed companies is of high quality and is required to have a laboratory germination of 80% or higher.

Seed size varies with hybrids but is generally in a range of 20 000 to 35 000 seeds per kilogram; seed of Alpha is much smaller and generally ranges from 45 000 to 65 000 seeds per kilogram.

APPROXIMATE PLANTING RATE FOR GIVEN PLANT POPULATIONS

Plants/ha	Planting rate kg/ha
50 000 ..	2.5
75 000 ..	3.75
100 000 ..	5.0
150 000 ..	7.5

Adjustments must be made for higher or lower populations and smaller seed size, for example Alpha. The efficiency of planting machinery is also variable.

## Lodging

Lodging is a major problem in many grain sorghum producing areas in Queensland. The most prevalent type of lodging in Queensland is that which follows moisture stress during the grain filling period. Under such conditions, all known grain sorghum hybrids and varieties will lodge. Lodging can also be associated with conditions other than moisture stress and hybrids relatively resistant to one form of lodging may be more susceptible to other forms.

Nevertheless, trial data and farmer experience have enabled classification of the hybrids as to their lodging resistance.

Because of the importance of lodging only lodging resistant hybrids are recommended for areas where lodging is known to be a problem. Other hybrid characteristics, particularly grain yield, determine the recommendations for areas where lodging is usually not important.

Lodging is not usually of importance in fully irrigated crops but can occur in well-grown, irrigated crops which experience moisture stress during grain filling.

### Crop maturity

In the guide, the varieties have been given maturity ratings. However, hybrid sorghum maturity is governed largely by temperature and to a lesser extent by day length. Varieties when sown in October in south Queensland would flower in 60 to 65 days but, the same varieties could be expected to flower in a much shorter period, 50 to 55 days, when sown in December.

The slow and medium-slow varieties may therefore react as mid-season types when sown later in the season.

### Head smut

Head smut, an important soil borne disease, is favoured by cool soil conditions. It is common in early plantings in south Queensland.

A 12% head smut incidence, which is common on highly susceptible varieties, represents a 12% yield loss.

Avoid sowing highly susceptible (HS) varieties early in areas where this disease is known to have occurred.

### Sugar cane mosaic virus (S.C.M.V.)

All grain sorghum varieties grown in Queensland are susceptible to the Johnson grass strain of sugar cane mosaic virus.

Three types of symptoms occur; these depend on varieties and environmental conditions.

The mosaic (M) symptom is shown by most of the recommended hybrids.

Under field conditions, the grain yield of mosaic reactors is little affected.

Red stripe (RS) reactors (Dorado E and Pacific 303) show a conspicuous red striping when infected. Early infection results in severe stunting and consequently a substantial yield loss.

There are two red leaf (RL) reactors, Q5161 and Sunlover I. When cool conditions follow infection, the mosaic symptoms change to red spots, streaks and areas of dead tissue; this is the red leaf symptom.

If severe red leaf disease occurs, substantial yield loss will result.

### Rust

Sorghum rust occurs in most districts throughout the State; it is more prevalent in late sown crops.

Severe rust infection in highly susceptible (HS) varieties has been associated with pinched grain and yield reduction. Premature plant death may also occur predisposing the plant to lodging.

## Grain Sorghum Planting Guide 1977-78

Region and Shires	Planting Time	Varieties	Planting Rate plants/hectare
<b>Burnett—</b> Miriam Vale, Kolan, Gooburrum, Woongarra, Isis, Perry, part Biggenden, part Tiaro, Woocoo, Hervey Bay	Sept.-Jan.	S: F64a MS: E57, NK266 For trial MS: Dorado MQ: Goldrush	75 000
Monto, Eidsvold	Nov.-Jan.	S: F64a MS: E57, Q5161, NK266, Sunlover I M: Texas 610 SR, NK212, Texas 626, Grainmaster A MQ: Goldfinger, NK233 For trial MS: Dorado, Leader MQ: Goldrush, Dorado E	75 000



Region and Shires	Planting Time	Varieties	Planting Rate plants/hectare
<b>Burnett—continued</b> Gayndah, Mundubbera, part Biggenden	Nov.–Jan.	S: F64a MS: E57, Q5161, NK266, Sunlover I M: Texas 610 SR, NK212, Texas 626, Grainmaster A MQ: NK 233, Goldfinger For trial MS: Dorado, Leader MQ: Goldrush, Dorado E	75 000
<b>South Burnett—</b> Kingaroy, Nanango, Wondai, Murgon, part Kilkivan, part Rosalie, (dark alluvial soils all districts)	mid Nov.–Dec.	MS: NK266, Dorado, Golden Acres Y101, E55e M: Texas 610 SR, NK212, Texas 626, Grainmaster A MQ: NK233, Goldfinger, Dorado E For trial MS: Leader M: Pride	75 000–100 000
Other soils all districts	mid Nov.–Dec.	MS: E57, Q5161, Sunlover I, Leader M: Pride MQ: Goldrush	
<b>Near North Coast—</b> Noosa, Widgee, part Tiaro, Maroochy, Landsborough	mid Nov.–end Jan.	MS: E57 MQ: Goldfinger, NK233	75 000
<b>East Moreton</b> Caboolture, Pine Rivers, Redlands, Albert, Beaudesert	Sept.–mid Jan.	Irrigated and Rain-grown MS: E57, Dorado M: Texas 610 SR, NK212, Texas 626, Grainmaster A MQ: Goldfinger, NK233, Dorado E	irrigated 250 000 rain-grown 100 000
<b>West Moreton</b> Moreton, Esk, Kilcoy, Boonah, Gatton, Laidley	Aug.–mid Jan. (Aug.–Sept. planting preferred)	Irrigated and rain-grown MS: E57, Dorado, Q5161, Sunlover I M: Texas 610 SR, NK 212, Texas 626, Grainmaster A, Dorado A MQ: Goldfinger, NK233, Dorado E	irrigated 250 000 rain-grown 100 000
<b>Darling Downs</b> Wambo, Chinchilla	Oct.–mid Jan.	Lodging soils MS: E57, Q5161, Sunlover I, Dorado, Golden Acres Y101 MQ: Goldrush For trial MS: Leader M: Pride	50 000

Region and Shires	Planting Time	Varieties	Planting Rate plants/hectare
Darling Downs— <i>continued</i> Wambo, Chinchilla— <i>continued</i>		Other soils MS: Dorado, NK266, Golden Acres Y101 M: Texas 610 SR, NK212, Texas 626, Grainmaster A MQ: Goldfinger, NK233, Dorado E  For trial MS: Leader M: Pride	100 000
Pittsworth, Millmerran (east of Condamine River), Jondaryan, Crows Nest, part Rosalie	Oct.–Nov.	MS: NK266, Dorado, Golden Acres Y101 M: Texas 610 SR, NK212, Texas 626, Grainmaster A MQ: Goldfinger, NK233, Dorado E  For trial MS: Leader M: Pride	100 000
Millmerran (west of Condamine River)	Oct.–Nov.	Forest soils MS: E57, Q5161, Sunlover I, Dorado, Golden Acres Y101 MQ: Goldrush  For trial MS: Leader M: Pride	50 000
Clifton, Allora, Rosenthal, Glengallan, Cambooya	Oct.–mid Nov.	MS: E57, NK266 M: Texas 610 SR, NK212, Texas 626, Grainmaster A MQ: Goldfinger, NK233, Dorado E  For trial MS: Leader M: Pride	75 000
Stanthorpe	Nov.–mid Dec.	MS: E57, Q5161, Sunlover I, Golden Acres Y101, Dorado  For trial MQ: Goldrush	75 000
Inglewood	Sept.–Oct.	MS: E57, Q5161, Sunlover I, Golden Acres Y101, Dorado  For trial S: F64a MQ: Goldrush	75 000



Region and Shires	Planting Time	Varieties	Planting Rate plants/hectare
<b>Darling Downs—continued</b> All districts	Sept.–Oct.	Irrigated MS: Texas 671, E55e, NK275, NK266, Golden Acres Tell, Dorado, Golden Acres Y101 M: Texas 610 SR, NK212, Texas 626, Grainmaster A MQ: Goldfinger, NK233, Dorado E  For trial S: F64a, Tropic, Big Red, Pacific 303	250 000
<b>Near South West</b> Waggamba	Sept.–Oct.	MS: E57, Q5161, Sunlover I M: NK212, Texas 626, Grainmaster A, Pride MQ: Goldrush, Goldfinger, NK233  For trial S: F64a MQ: Dorado E	75 000
Balonne	Dec.–Jan.	Irrigated only S: F64a MS: Texas 671, E55e, NK275, NK266, Golden Acres Tell, Dorado, Golden Acres Y101 M: Texas 610 SR, NK212, Texas 626, Grainmaster A	250 000
Murilla, Tara, Taroom	Late Sept.–Oct. and Late Dec.–Jan	S: F64a MS: E57, Q5161, Sunlover I M: Pride MQ: Dorado E, Goldrush Q: Pacific 001	50 000
Bungil, Bendemere, Waroo, Booringa	Late Dec.–Jan.	MS: E57, Q5161, Sunlover I  For trial M: Pride MQ: Goldrush, Dorado E	50 000–75 000

KEY.—S = Slow maturity; MS = Medium slow maturity; M = Medium maturity; MQ = Medium quick maturity;  
Q = Quick maturity.

For further information on varietal performance in your own district, consult your Agricultural Extension Officer.

## Guide to Grain Sorghum Hybrid Characteristics

by R. G. HENZELL, Senior Plant Breeder, P E. MAYERS, Plant Pathologist and O. W. DUNCAN, Executive Officer, Queensland Graingrowers' Association

Seed Company	Hybrid	Time of Flowering	Head Smut	Sugarcane Mosaic Virus Reaction	Rust	Lodging	Height	Head	Grain Colour
Yates	NK147 ..	Q	R	M	HS*	Below average	MS	Semi-compact	Red
	NK233 ..	MQ	R	M	S	Average ..	M	Semi-compact	Bronze
	NK220Y ..	M	R	RS	S*	Average ..	MS	Semi-open ..	Bronze
	NK207 ..	M	HS	M	S*	Average ..	MS	Semi-compact	Red
	NK212 ..	M	R	M	R	Average ..	M	Compact ..	Red
	NK266 ..	MS	R	M	S	Average ..	MT	Semi-open ..	Bronze
	NK300F ..	S	R	M	..	Below average*	VT	Semi-compact	Brown
	NK275 ..	MS	R	M	S	Average ..	M	Compact ..	Red
Pacific	001 .. ..	Q	S	M	HS	Average ..	S	Semi-open ..	Red
	Goldfinger ..	MQ	R	M	S	Average ..	M	Semi-open ..	Bronze
	Goldrush ..	MQ	S	M	HR	Good* ..	M	Semi-open ..	Red
	303 .. ..	S	R	RS	R	..	T	Semi-compact	Red
	Tropic ..	S	R	M	..	Average* ..	T	Open ..	Bronze
	Pacific 710 ..	M	R	M	R	Average ..	M	Compact ..	Red
	Monsoon ..	S	..	M	..	..	T	Semi-open ..	Red
Asgrow	Dorado E ..	MQ	R	RS	R	Above average	MS	Semi-compact	Bronze
	Dorado A ..	M	R	M	S	Below average*	M	Semi-open ..	Bronze
	Rico .. ..	M	R	M	S	Above average*	M	Compact ..	Red
	Dorado ..	MS	R	M	R	Above average	MS	Open ..	Bronze
Golden Acres	Grainmaster A	M	R	M	S	Average ..	M	Compact ..	Red
	Y 101 ..	MS	R	M	R	Above average	MS	Open ..	Bronze
	TELL ..	MS	R	M	S*	Average ..	MT	Compact ..	Red
Panorama	Texas 610 SR	M	R	M	S	Average ..	M	Compact ..	Red
	Q 5161 ..	MS	HS	RL	R	Good .. ..	M	Compact ..	Bronze
Hylan	Texas 610 SR	M	R	M	S	Average ..	M	Compact ..	Red
	Q 5161 ..	MS	HS	RL	R	Good .. ..	M	Compact ..	Bronze
	Texas 671 ..	MS	R	M	R*	Average ..	MT	Compact ..	Red
	Texas 626 ..	M	R	M	S	Average ..	M	Compact ..	Red
	Alpha ..	MS	S	M	S	Good .. ..	MS	Semi-compact	Red



Seed Company	Hybrid	Time of Flowering	Head Smut	Sugarcane Mosaic Virus Reaction	Rust	Lodging	Height	Head	Grain Colour
De Kalb	B17 .. ..	Q	HS	M	HS	Below average	M	Semi-open ..	Brown-red
	C 42T .. ..	M	R	M	HS	Above average	M	Semi-compact	Bronze
	E 55e .. ..	MS	R	M	R	Above average*	M	Semi-compact	Red
	E 57 .. ..	MS	HS	M	R	Good .. ..	M	Open .. ..	Bronze
	F 64a .. ..	S	R	M	R	Good .. ..	T	Open .. ..	Bronze
	FS 1a .. ..	Q	R	M	..	Below average*	VT	Compact ..	Red
Pioneer	Pride .. ..	M	R	M	R	Above average	MS	Semi-compact	Bronze
	Leader .. ..	MS	HS	M	R	Above average	MS	Open .. ..	Bronze
	Big Red .. ..	S	S*	M	R*	..	M	Semi-compact	Red
	Pioneer 846 ..	MS	R	M	HS	Average ..	M	Semi-compact	Red
	Texas 610 SR ..	M	R	M	S	Average ..	M	Compact ..	Red
	Texas 626 .. ..	M	R	M	S	Average ..	M	Compact ..	Red
	Q 5161 .. ..	MS	HS	RL	R	Good .. ..	M	Compact ..	Bronze
	Sunlover I .. ..	MS	HS	RL	R	Good .. ..	MS	Semi-compact	Bronze
	Quicksilver ..	Q	HS	M	..	Below average	S	Open .. ..	Red
Selected Seeds	Q 5161 .. ..	MS	HS	RL	R	Good .. ..	M	Compact ..	Bronze

KEY—Time to flowering: Q = Quick; MQ = Medium quick; M = Medium; MS = Medium slow; S = Slow.

Lodging behaviour ratings: Good, above average, average, below average.

Height: VT = Very tall; T = Tall; MT = Medium tall; M = Medium; MS = Medium short; S = Short.

Head: Open, semi-open, semi-compact, compact. Compact heads dry less rapidly and are more susceptible to head caterpillars.

Head smut: R = Resistant; S = Susceptible; HS = Highly susceptible.

Leaf Rust: HS = Highly susceptible; S = Susceptible; R = Resistant; HR = Highly resistant. These classes are relative to each other, the dividing line being somewhat arbitrary.

Sugarcane mosaic virus reaction: M = Mosaic; RS = Red stripe; RL = Red leaf.

\*Based on less than two years' data.

# The Dual Role of the Pasture-furrow

by J. A. FAIRBAIRN, Soil Conservation Branch.

DURING the last few years, landholders in the Nanango, Kingaroy and Northern Rosalie Shires of the South Burnett have treated considerable areas with pasture-furrows.

They had several motives for using this technique.

## **The retention of water to improve plant-growth**

By inducing greater water absorption by the soil-profile, pasture-furrows provide more moisture for use by the growing plant. This is of special importance during the establishment of new, improved pastures in areas where moisture-stress may be relieved by high intensity rainfall which induces run-off. Furthermore, an earlier, healthier sward means quicker leaf-cover and added protection from erosion.

## **The reduction of run-off to achieve control of soil erosion**

Pasture-furrows spread excess rainwater within the treated area and should not allow it to form eroding streams. They also impede

and pond the run-off to give the soil more time for absorption. This limits the volume of water available for soil erosion.

## **Application**

Pasture-furrows may be introduced as soon as practicable after the sowing of new pasture (the same day if possible). Before the pasture emerges the paddock is at its most vulnerable stage as far as erosion is concerned. The furrows will give some insurance against the effects of heavy rain as well as retaining potential run-off for use by the young plants.

*After the storm: potential run-off ponded in a 'tied' pasture-furrow.*





Even established, improved pasture is subject to sheet erosion and moisture-loss through run-off under high-intensity storm conditions. Pasture-furrows should minimise the loss of both soil and water.

Furrows in native pasture may be used to increase productivity or help the introduction of new species. Seed in and around the furrow stands a better chance of survival.

A novel variation was employed by Mr W. Mowat, a Yarraman dairy-farmer. Mr Mowat, keen to introduce kikuyu into native pasture, placed sods of kikuyu at intervals along the furrows to act as 'ties'. The kikuyu is now spreading through the paddock.

Pasture-furrows may be of greater benefit on certain soil-types than on others. Soils which have a low infiltration rate, like the 'snuffy' red forest soil or the surface-sealing duplex soils (which are soils with a definite texture-change in their profiles and often with a heavy clay subsoil), will obviously benefit more than a friable, open-textured scrub soil. Problems could occur, however, in duplex soils with highly dispersible clay subsoils.

Pasture-furrows are not always the only answer; regular deep-ripping and/or chisel-ploughing may be an alternative to, or complement, pasture-furrowing, depending on soil permeability.

### Construction

The level guide-lines are surveyed and marked out at no cost by officers of the Soil Conservation Branch. A pasture-furrow is simply a furrow opened along these level lines with the soil usually turned downhill.

The following machinery can be used for construction:

- A disc plough (using only one or two of the rear bodies).
- The toe of a tilted dozer-blade.
- The heel of the grader-blade.
- A specialized machine using either disc or mould-board ploughs and rippers.

As it is impossible to achieve absolute accuracy in construction, it is necessary to incorporate 'ties' in the furrow at regular intervals in order to prevent water flowing to possible low spots. A specialized machine should do this automatically—otherwise they must be built manually.

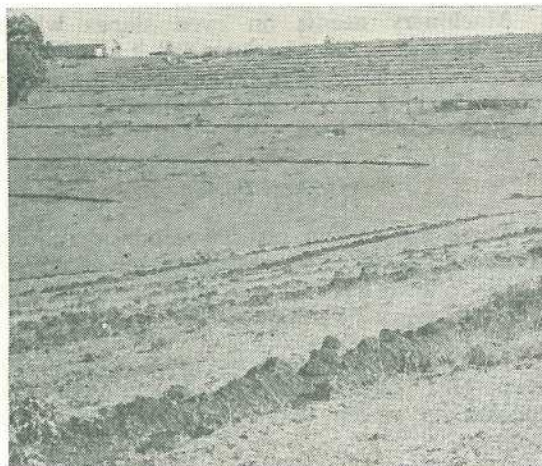

*Recently-built pasture-furrows in improved pasture near Kingaroy.*

Obstructions such as fence-lines, rocky outcrops, stumps or trees offer no impediment to pasture-furrowing; the obstruction can be ignored and the furrow opened where the survey line is clear and the plough can penetrate easily. Unlike contour-banks, a pasture-furrow need not be continuous.

After a period of years, the furrow will need reopening to maintain its efficiency. The frequency for such maintenance will depend on the soil structure.

### Spacing

There are four major considerations concerning the spacing of pasture-furrows:

**Slope;** the steeper the ground, the quicker surface-flow will achieve scouring velocity. So, as with contour-banks, the furrows should be placed progressively closer together as the slope increases.

**The stage of pasture-establishment;** before leaf-cover is achieved in a new pasture, the erosion-control function of the furrows is critical—they must, therefore, be closely-spaced.

**Soil permeability;** land with a high infiltration-rate does not have to rely as much on the ponding effect of the furrows—so a wider spacing may be used than on less permeable soil.



**Machinery needs;** on even slopes where mowing and baling are intended it is possible to space the furrows in multiples of the width of haymaking machinery to allow a certain number of runs between the furrows.

### Restrictions

There are certain restrictive considerations to the application of pasture-furrows. Many of the following points are trivial but some will apply in every situation.

The slope must not be great enough to jeopardize the safety of construction machinery which have to travel on the contour.

Pasture-furrows on steep hillsides offer a hazard to carelessly-driven farm machinery.

On areas where mowing and baling are practicable, the furrows would be an inconvenience to those operations except where the slope is even enough to allow paralleling.

Wheeled travel over the treated area is restricted to the contour, chosen tracks and the perimeter.

Pasture-furrows could be the cause of an animal stumbling (such as a hard-ridden horse).

If water is ponded in the furrow for extended periods, legumes in the pasture-mixture may suffer—though the detrimental effect will be confined to the furrow itself.

In sheep country, the furrows may be the cause of unshorn sheep being unable to regain their feet after having rested in a furrow.

The maintenance or reopening of the furrows every few years constitutes an extra farm operation.

When pasture-furrows are introduced into established pasture the area disturbed can be expected to remain unproductive until the following growing season.

### Value

Grazing land is becoming more expensive and landholders are becoming more aware of the benefits of proper grassland management. Pasture-furrows are an aid to the better use of rainfall and constitute an insurance against the gradual denudation by erosion of our most valuable capital asset—the land.

---

## Use of symbol brands and earmarks

- An earmark may only be used on a beast which already bears a three piece or symbol brand.
- A symbol brand must be registered in conjunction with a three piece brand. However, either may be used alone to denote ownership.



# The spotted alfalfa aphid,

# a new pest of lucerne

THE spotted alfalfa aphid (*Therioaphis trifolii* f. *maculata*) is a serious pest of lucerne and related crops in overseas countries.

The pest was recorded for the first time in Queensland on 29 March 1977.

Initial surveys have shown that it is established in the Lockyer Valley, Darling Downs, Brisbane Valley and in some regions in southern States. In Queensland, it has caused severe damage to lucerne in the Lockyer Valley where pest populations ranging up to 500 aphids per stem have been recorded.

The aphid is widely distributed in Europe, Asia, Africa and North America having been recorded as attacking a range of leguminous hosts including lucerne, burr medic, crimson clover and some *Melilotus* species. It does not, however, attack red, white or subterranean clover, vetches, peanuts, navybeans, soybeans, peas, etc.

Spotted alfalfa aphids are pale yellow in colour with six or more rows of black spots along their backs. They have a fairly characteristic habit of jumping or dropping to the ground when infested plants are disturbed. Adults which are usually about 1.5 mm in length may be wingless or winged, the latter possessing smoky areas along the wing veins.

Females usually produce living young and reproduction is mostly without mating as males are rare. Breeding is quite rapid with only 1 to 2 weeks being reported as necessary for each generation. In overseas areas, from 20 to 40 generations per annum have been recorded, depending on weather conditions.

The pests feed directly from the water-conducting tissues of host plants, primarily from the leaves. Macroscopic evidence of injury include chlorotic spots on the leaves, leaf vein yellowing followed by leaf yellowing and leaf drop.

The aphids secrete a sticky honey dew which interferes with cutting, drying and baling and a black mould thrives on the honey dew discolouring the plant. Hay quality and yield are reduced. Severe infestation may kill plants with resultant invasion by weeds. Infestation has been noted as most severe on seedlings and two aphids per seedling have caused the destruction of recently planted stands in overseas areas.

by T. PASSLOW, Entomology Branch

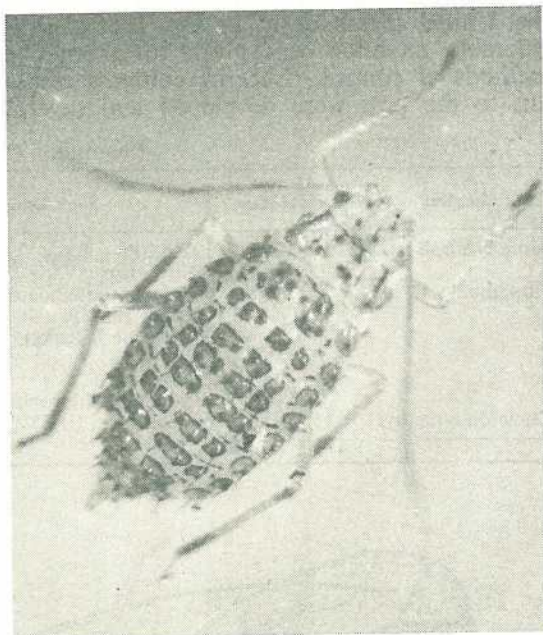

This wingless spotted alfalfa aphid was photographed through a microscope. Its natural size is approximately 1.5 mm.

Available information shows that the pest will survive over a wide range of field conditions. Field infestations indicate that it will be a serious pest of lucerne in Queensland.

Initial insecticide tests carried out by Entomology Branch staff indicate that chemicals such as monocrotophos demeton-s-methyl and dimethoate at dosages as low as 100, 150 and 150 g active per hectare respectively will give control. However, pest resurgence is highly likely following chemical control and the possibility of more than one application of pesticide being required between consecutive cuts is likely when conditions suit the insect.

It is suggested that insecticide be applied to infested stands as soon as possible after cutting to ensure maximum chances for rapid, vigorous growth. Requirements for further treatment can then be assessed on population resurgence and experience in gauging the effects of infestation.

Insecticide treatment is unlikely to give entirely satisfactory results and should be regarded as an interim measure to be used until other control techniques can be developed.

Following the introduction of the pest to the United States early in the 1950s, considerable attention was given to alternative methods of control. Lucerne cultivars resistant to the pest were developed and several

tiny wasp parasites of the insect were introduced. As a result of these programmes, losses caused by the pest have been minimized.

The Department of Primary Industries, together with interstate organizations, has initiated similar programmes in Australia. Overseas cultivars developed for resistance to the aphid are already available for study in our environment, and selection for resistance within present commercial cultivars will be investigated.

Initial steps toward the introduction of biological control organisms have been made. Clearly, this and resistant varieties are the most promising avenues for the ultimate control of this pest.

#### INSECTICIDE CONTROL SUMMARY

Chemical	Dosage Rate	Some Commercial Products and Application Rates	Withholding Period (Days)
Monocrotophos	100 g/ha	Asodrin } 40% act. con.—250 ml/ha .. .. .	7
		Nuvacron }	
Dimethoate ..	150 g/ha	Nufarm dimethoate } 40% act. con.—375 ml/ha .. .. .	7
		Rogor ridmite }	
		BASF perfekthion }	
		Rogor EC }	
		Lane rogor }	
		Campbell chloropest }	
Demeton-s-methyl	150 g/ha	Metasystox (i) 25% act. con.—600 ml/ha .. .. .	21

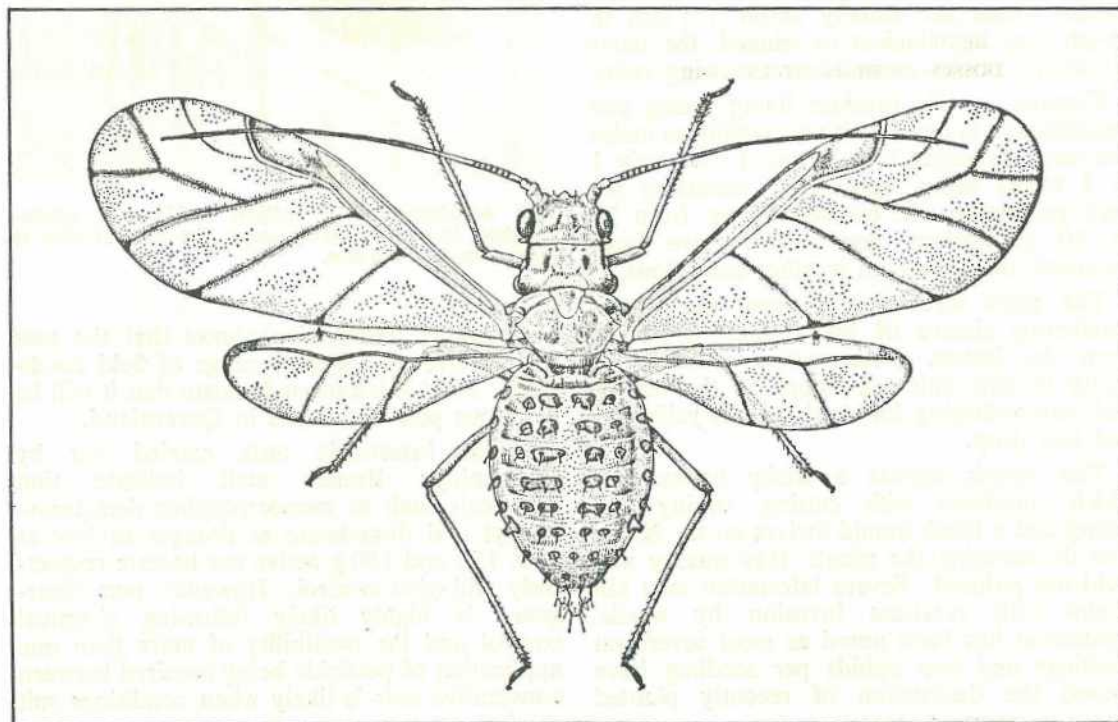

A winged adult female.



## Big Head Disease in horses at pasture

by J. C. WALTHALL,  
Veterinary Services Branch.

PREVIOUSLY, this disease was thought to occur only in stabled horses fed high grain rations.

Since 1973, many horses running on improved pasture in Queensland have developed *Osteodystrophia fibrosa* (O.D.F.) or Big Head Disease.

On most of the affected properties, O.D.F. is controlled by a slight alteration in management routines. On a few properties, complete control is proving most difficult.

Plate 1. Three affected horses on a well established buffel pasture. Note the swellings of the facial bones and the poor condition of two horses.

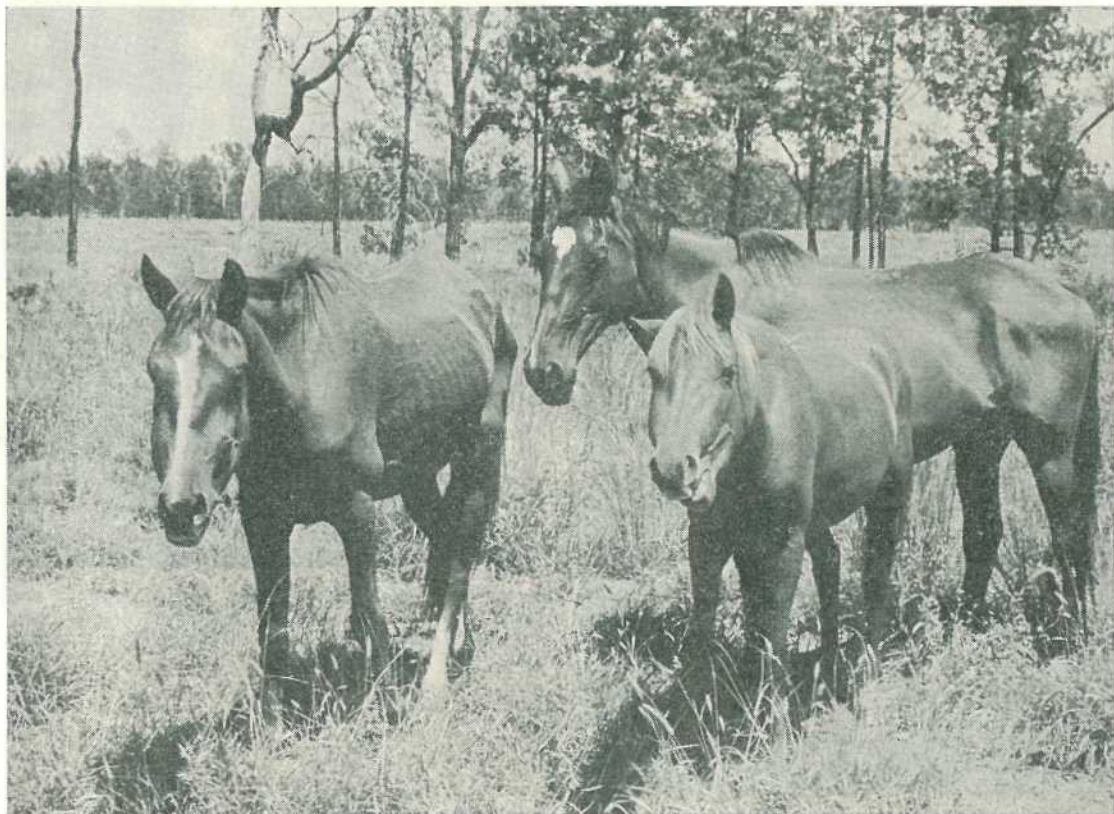

### Clinical signs

O.D.F. may cause any of the following signs either individually or in various combinations.

- **ILL-THRIFT.** Horses show harsh coats and may lose considerable body condition while grazing on pastures appearing to contain adequate nutrients. Some animals may show only a lowered work tolerance, while more severely affected animals can become extremely poor in condition and even die.
- **LAMENESS.** Horses will show varying degrees of lameness. Slightly affected animals may move normally at slow speeds (walking) and show only a slight shortening of gait at higher speeds. These animals tend to lag behind in a mob of cantering horses. More severely affected animals may show a non-specific, shifting lameness. This lameness is very difficult to associate with any particular leg or joint. In fact, lameness may vary from one day to the next. Sometimes, after a few hours work, a horse may develop signs of shifting lameness.

In the extreme form, animals may have difficulty in rising. This condition is made worse by cold weather.

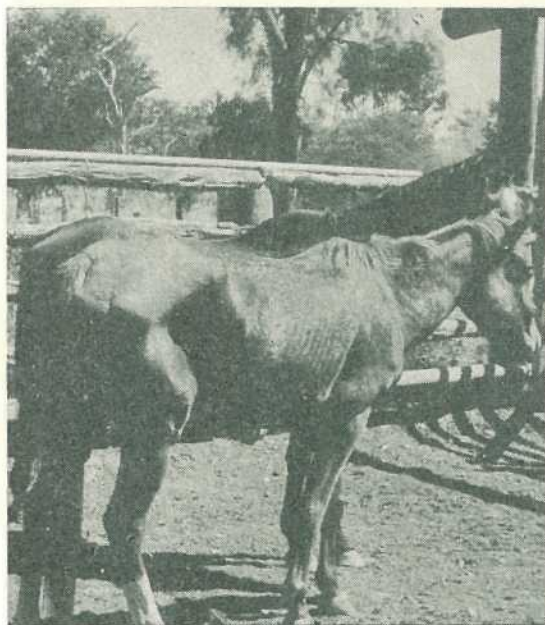

Plates 2 (above) and 3. Poor body condition and swellings of head bones are two signs of Big Head Disease. These plates show the front view and side view of an affected horse.



- **SWELLINGS OF BONES OF THE HEAD.** This is the easiest form of O.D.F. to recognise. Usually, swellings occur on the facial bones (just above the cheek teeth) and on the lower jaw bones.

Generally, swellings occur on both sides of the horse's head, but are not necessarily of the same size. On first developing, these swellings are soft enough to indent by finger pressure or cut with a sharp knife but with time the swellings become progressively fibrosed and hard.

A mid-line swelling of the nasal bones may be seen approximately one third of the distance between the eyes and nostrils. The centre horse in plate 1 clearly shows this swelling.

Sometimes a nasal discharge is evident in affected horses.

### Post mortem findings

The only visible changes occur in horses showing swellings of facial bones and jaw bones. All other organs appear normal. See plate 9.



Plates 4 (below) and 5. The signs of Big Head Disease are variable. The horse below shows poor body condition, rough coat and swelling of cheek bones. The horse above shows only swelling of head bones (jaw bone, cheek bone and nasal bone).

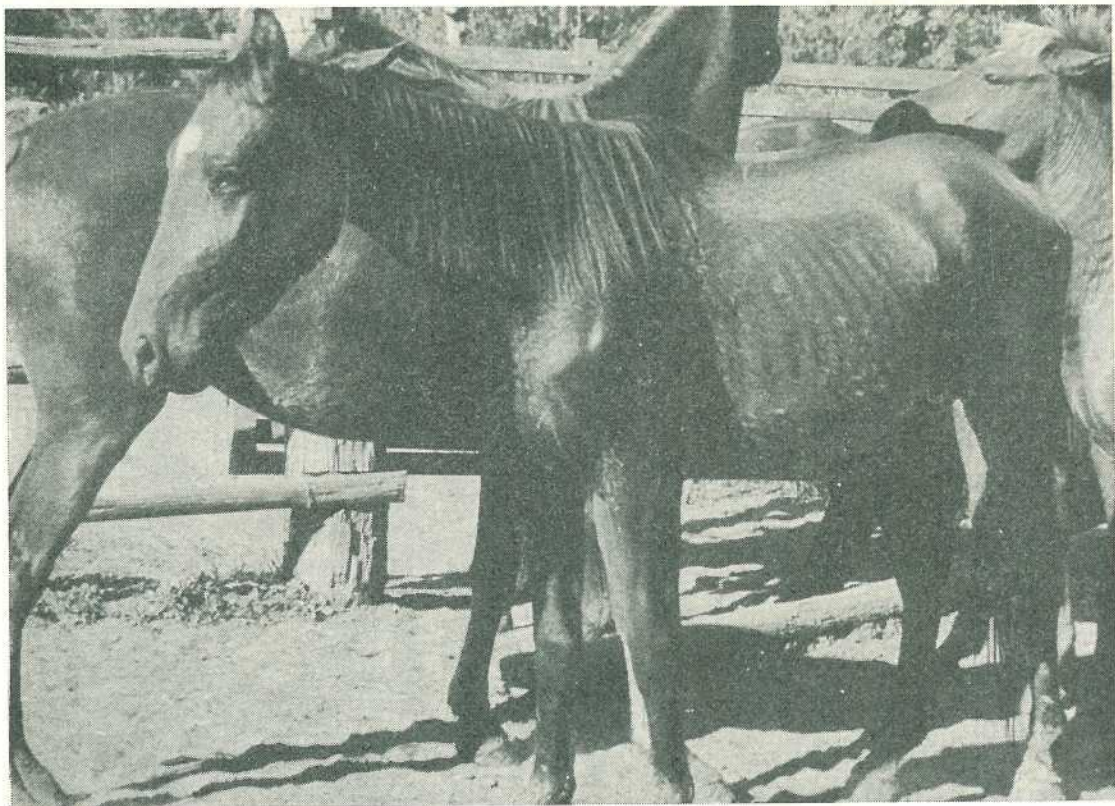



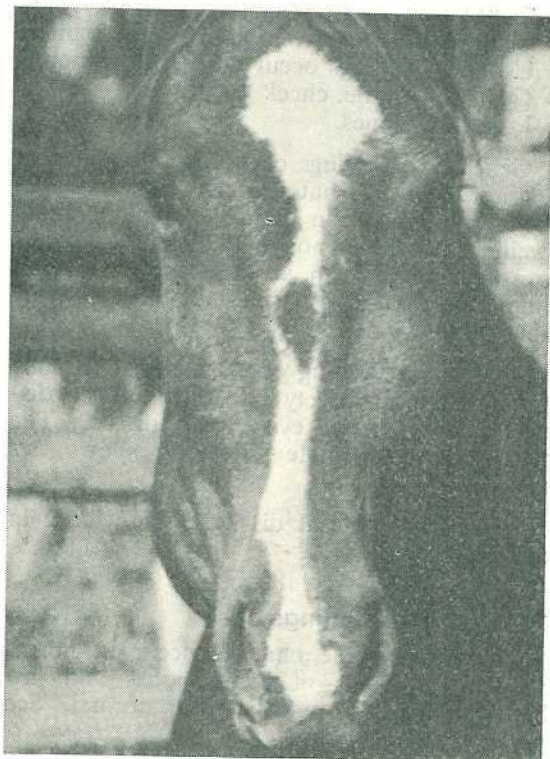

Plates 6, 7 and 8. Big Head Disease may cause grotesque swelling of a horse's head. These three views of the same horse demonstrate this. Note the horse's good body condition despite the severity of the head swelling.





## Incidence and distribution

To July 1974, O.D.F. had been observed on over 30 properties in 17 Shires.

A survey (July, 1976) of the four Central Highland Shires (Belyando, Peak Downs, Emerald, and Bauhinia) revealed that 10% of properties have been affected at some stage by O.D.F. More than half of these properties still have a problem with this disease.

It is estimated from the survey that 2% of horses in these four Shires have been affected either temporarily or permanently by O.D.F.

Buffel grass (*Cenchrus ciliaris*) was the major pasture grass grazed by most affected horses. Other pasture types incriminated include green panic (*Panicum maximum* var *trichoglume*), para grass (*Brachiaria mutica*), setaria (*Setaria anceps* cv *nandi* and *kazungula*), kikuyu (*Pennisetum clandestinum*) or mixed pastures containing buffel and green panic and siratro (*Macroptilium atropurpureum*).

The effects of the disease were more severe on those properties where horses continually grazed almost pure stands of these introduced plant species.

Conversely, the effects were minimal where horses were rotated between these pastures and native pastures.

## Cause of Big Head

• **GENERAL.** An imbalance of calcium and phosphorus (less calcium than phosphorus or a simple deficiency of calcium in a horse's diet over a period of time can cause O.D.F. Signs may develop after 6 to 12 months' feeding of a marginally imbalanced ration. If the ration is grossly imbalanced, O.D.F. may appear after 2 to 3 months.

Most pastures contain levels of calcium and phosphorus which do not produce O.D.F. Previously, O.D.F. was regarded as occurring only in stabled horses, fed high grain rations. (Many grains contain much more phosphorus than calcium. This disease was once known as 'bran disease').

If a horse is fed a calcium deficient diet, calcium requirements are satisfied initially from its calcium reserves. Bone is the main reserve of calcium. After a period of time under these conditions, the bone becomes

weakened and various changes take place which cause swelling, softening and a greater tendency to fracture.

Lameness is thought to be caused by microscopic changes in the surfaces of the bone joints (especially the spine and limbs).

• **PASTURE IN QUEENSLAND.** None of the pastures incriminated in the recent outbreak of O.D.F. in Queensland showed any imbalance between calcium and phosphorus levels.

Dung analysis of horses grazing these pastures revealed relatively high levels of calcium compared with phosphorus. This indicated that calcium absorption from the horse's intestinal tracts was being impaired by some factor.

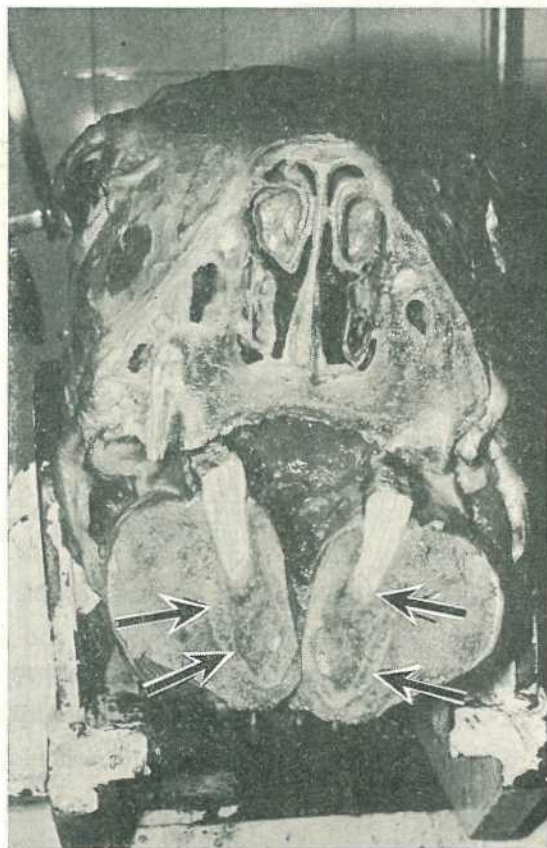

Plate 9. Transverse section of a horse's head. Note the swelling of the lower jaw bone. The outline of the original jaw is still evident (arrows).

Analysis of suspect pastures revealed that these contained varying levels of oxalates whereas native pastures contained very low levels. These levels are higher during phases of active plant growth especially during very wet periods.

It is strongly suspected that much of the plant calcium combines with oxalic acid to form insoluble calcium oxalate. This could prevent absorption of calcium by the horse and consequently produce a calcium deficiency. If the deficiency continues for some months, O.D.F. may result.

### Prevention and control

The most effective method of control is to remove horses from improved pastures and place them in paddocks where only native pasture is available.

If this is impractical, then horses should be rotated between paddocks containing improved pastures and paddocks containing only native pastures. Horses should not be left in improved pastures for longer than 4 to 6 weeks, especially during periods of lush plant growth.

If the only pastures available on a property are these improved pastures, then the disease will be very difficult, if not impossible, to control during long, wet seasons.

Some form of calcium supplementation is required. One way of achieving this is by feeding ground limestone and/or legume hays. The amount of calcium supplementation required will vary from horse to horse and from property to property. The only recommendation can be that these supplements should be fed ad lib.

Some people are achieving reasonable success by supplementing with 30 to 60 grams (1 to 2 ounces) of ground limestone per horse per day. Ground limestone is the cheapest form of available calcium.

There are reports of ground limestone by itself or mixed with dry feeds being unpalatable. Molasses mixed with the ground limestone should alleviate this problem.

### Treatment

The best treatment is to change a horse's ration. The quickest, cheapest and most effective way to achieve this is to put the affected animal in pasture containing only native grasses.

Failing this, horses should be fed high calcium/low phosphorus supplements such as ground limestone or lucerne hay.

### Further reading

J. C. Walthall and R. A. McKenzie (1976) *Australian Veterinary Journal*, Vol. 52, pp. 11-16.

---

## CHANGING YOUR ADDRESS?

Please let us know as soon as possible if you intend changing your address.

Because the addressed wrappers and journals are printed separately, changes cannot take effect until the next batch of wrappers is printed.

This means that, in some cases, subscribers will receive the next issue at their old address.

If possible, two months' notice should be given to ensure your journal is sent to the correct address.



# Colour grade tomatoes for higher returns

compiled by R. H. Adams, Standards Branch.

TODAY'S tomato growers realise that better prices and higher returns can be achieved by colour grading fruit to meet market requirements.

Good quality, firm lines, evenly graded for colour development, are in strong demand and attract premium prices on all markets.

Green fruit cannot be graded evenly. Backward, green lines invariably develop as poor quality, mixed, ripe fruit for which there is little demand. On the other hand, fully ripe fruit will deteriorate quickly and is frequently sold at clearing prices.

Ethylene ripening under controlled temperature conditions is used extensively to colour mature, green fruit. With rapid cooling and refrigerated or insulated transport, coloured fruit can be put on all markets in virtually the same condition in which it was packed.

Quality and flavour are also important features. These are highest in fruit that is allowed to mature on the vine.

Immature fruit is slow to ripen and develops into poor quality fruit which lacks flavour.

Fruit ripened at high temperatures is soft and does not develop the rich, red colour that buyers demand.

For best results, the following procedure is recommended.

- Harvest only fully mature fruit.
- Ripen green fruit under controlled temperature conditions to ensure optimum colour development.
- Colour grade to meet market requirements.
- Cool rapidly to hold colour development and retain quality.
- Market under refrigerated conditions.

## When is a tomato mature?

Regulation (22) of the Fruit and Vegetable Grading and Packing Regulations, states:

“Mature” means that the tomato has reached its maximum growth and has reached or passed the stage when—

- (a) Its skin has changed from a dull green to a bright green colour; and
- (b) the contents of the seed cavity have changed from a light green to a deep amber or to a deep amber tinged with pink.

In addition, immature fruit have little or no gel formation in the seed cavity and the seeds are firmly held.

A guide that is widely used by growers is that a sharp knife used to slice an immature fruit will cut the seed while in a mature fruit the seeds will move past the blade.

## Colour grades

The following colour gradings and markings have been approved by the Queensland Fruit and Vegetable Industry and are recommended for use by growers.

‘Green’ means that the surface of the tomato is completely green in colour. The shade of green colour may vary from light to dark. No marking is required on the carton for green fruit.

‘Backward colour’ means that all fruit in the package are showing a definite break in colour from green to tarnish-yellow, pink or red, but on not more than 30% of the surface. Cartons should be marked ‘B/C’.

‘Semi-colour’ means that on all fruit in the package more than 30% but not more than 60% of the surface shows pink or red colour. Cartons should be marked ‘S/C’.

‘Forward colour’ means that on all fruit in the package more than 60% of the surface shows pinkish-red or red but the fruit is not a full red colour. Cartons should be marked ‘F/C’.

‘Red ripe’ means that the full surface of the fruit has developed a red colour. Cartons should be marked ‘RIPE’.





*High quality lines of mature, green fruit are in strong demand.*



*High quality, even lines of coloured fruit attract premium prices.*



*Backward, green fruit develops into poor quality, mixed, ripe packs.*



*Mixed, ripe packs are in little demand.*



*Red, ripe fruit deteriorates quickly when not kept under refrigeration.*



*Fruit ripened at high temperatures is soft and tends to have a high percentage of yellow and less red colour.*





*Green.*



*Backward colour.*



*Semi-colour.*



*Forward colour.*

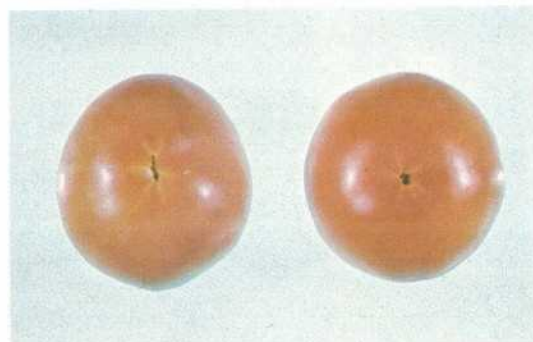

*Ripe.*



*Mature fruit showing gel and amber to pink colour development in seed cavities.*

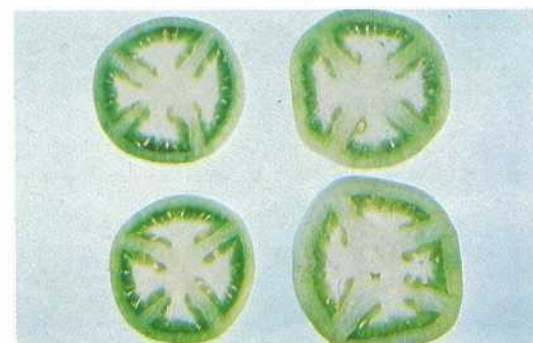

*Immature fruit. Note lack of gel and green colour of seed cavities and cut seeds.*

# D.P.I. Market Service



## Inspection

EXAMINATION of fresh produce offered for sale on Queensland markets is a major activity for Standards Branch Inspectors under the Fruit and Vegetables Act.

Tomato maturity has attracted a lot of attention over recent months and immature fruit has been withheld from sale.

Backward, green fruit is slow to ripen and of poor quality. Growers having problems with maturity were referred to the district Horticultural Extension Officers for assistance.

In the adjacent photograph (above left), Roger Meurant, Inspector at the Rocklea Markets, discusses tomato maturity and presentation with Peter Warhurst, Technologist with the Fruit and Vegetable Marketing Extension Service.

## Extension

Standards Branch personnel now operate a Market Extension Service from wholesale fruit and vegetable markets in Brisbane, Toowoomba, Rockhampton, Townsville and Cairns.

The service provides market feedback to growers on quality, presentation, packaging, handling and transport, through local extension personnel.

Working in conjunction with other Branches of the Department, the Committee of Direction of Fruit Marketing, The Chamber of Fruit and Vegetable Industries, Brisbane Market Trust and other industry groups, officers are actively involved in co-ordinating developments within the marketing system.

At a recent demonstration at the Rocklea Markets, Maurice Jones of Ern Mackie Pty. Ltd., discussed features of their 'Tier Rack' with Guy Short, Chief Market Reporter and Harley Adams, Technologist with the Market Extension Service (lower left).

The 'Tier Rack' was seen in operation in the Sydney Market. It is a detachable steel frame for fitting to and stacking loaded pallets and is ideally suited for operation in confined spaces.

Palletizing of fresh fruit and vegetables is a well established practice in Queensland. Racking in the markets combined with unitizing of consignment on the farm will eliminate unnecessary handling in transit, reduce damage and realise the full cost advantages of mechanization.





# Registered Fertilizers

compiled by the Chemical Services Section, Standards Branch

IN Queensland, the sale of fertilizers is governed by the *Agricultural Standards Act 1952-1972* which provides for the registration, inspection and analysis of materials claimed to supply plant nutrients.

Before a fertilizer is offered for sale in this State, the Queensland primary dealer is required to submit an application for registration to the Standards Branch, Department of Primary Industries. The information supplied in this application is carefully scrutinised to prove its accuracy and the guaranteed analysis shown on the label is checked to see that it correctly specifies the ingredients of the fertilizer.

If this information fulfils in all respects the requirements of the Act and the Regulations thereunder, the fertilizer is duly registered and may then be sold throughout Queensland in accordance with the abovementioned Act.

When offered for sale the preparation is subject to inspection by Departmental officers, who regularly sample and analyse stocks of fertilizer held by merchants as a check on the standard of commercial grades.

It is essential that materials offered for sale comply with the requirements of the Act and every product must meet the guaranteed analysis as shown on the label. If samples fail to comply with these requirements the bulk to which they relate is withheld from sale until all deficiencies have been corrected, and legal action may be taken against the trader concerned.

A most important provision of the Act is that a clearly printed label must be attached to each package of fertilizer setting out the following information:—

- (1) The name of the fertilizer.
- (2) The net weight of the fertilizer.
- (3) A statement setting out—
  - (a) the names and respective percentages of active constituents and the form or forms in which they occur; for example:—  
4.0% nitrogen (N) as ammonium sulphate

2.0% nitrogen (N) as blood and bone

5.0% phosphorus (P) as bone

5.0% water soluble phosphorus (P) as superphosphate

4.5% potassium (K) as potassium chloride

4.8% sulphur (S) as sulphate  
or, for chemically compounded fertilizers including those containing ammoniated superphosphate:—

4.0% nitrogen (N)—ammonium form

1.0% nitrogen (N)—nitrate form

8.0% phosphorus (P)—water soluble

2.0% phosphorus (P)—insoluble

4.0% potassium (K) as potassium chloride

4.5% sulphur (S) as sulphate.

(b) The percentage and kind of filler, if any.

(c) In the case of insoluble fertilizers, the degree of fineness.

(4) The name and address of the primary dealer or manufacturer.

This information is provided for the benefit of the farmer. It enables him to ascertain the contents of the fertilizer, to select a fertilizer to suit his particular requirements and to calculate the unit value of the fertilizer which is a guide to its correct price.

**It is strongly recommended that farmers examine fertilizer labels closely and refuse to accept bags to which a label is not attached.**

Enquiries relating to this article should be addressed to the Standards Branch, Department of Primary Industries, Meiers Rd., Indooroopilly, Qld., 4068. Telephone—(07) 371 3511.

# Fertilizers

REGISTERED UNDER THE AGRICULTURAL STANDARDS ACT 1952-1972 AS AT 19 NOVEMBER, 1976

Name of Preparation	Guaranteed Analysis						Queensland Primary Dealer
	Percentage Nitrogen (N)	Percentage Phosphorus (P)	Percentage Potassium (K)	Percentage Miscellaneous	Percentage Fine	Percentage Coarse	
<b>ORGANIC FERTILIZERS</b>							
<b>BONE</b>							
Attunga Orchid Company Horticultural Bone Flour	..	As bone 13.0	..	28.5 calcium (Ca) as bone	..	..	Acacia Nurseries
<b>DRIED BLOOD</b>							
Borthwicks Bowen Dried Blood	As blood 12.8	..	..	..	74.0	26.0	Thomas Borthwick and Sons (Australasia) Ltd.
TB & S Moreton Dried Blood	12.8	..	..	..	74.0	26.0	Ditto
<b>HOOF AND HORN</b>							
Attunga Orchid Company Hoof and Horn Fertilizer	As hoof and horn 12.0	As hoof and horn 1.3	..	..	..	..	Acacia Nurseries
<b>MEATWORKS</b>							
ACF-Austral Blood and Bone	As blood, bone and offal 4.0	As bone 8.7	..	15.3 calcium (Ca) as bone	60.0	40.0	Consolidated Fertilizer Sales Pty. Ltd.
Blood and Bone Fertilizer	4.5	7.7	..	15.4 calcium (Ca) as bone	65.0	35.0	Hutton Brothers
Blood and Bone Fertilizer	5.5	6.0	..	12.0 calcium (Ca) as bone	85.0	15.0	Mangan Brothers



Name of Preparation	Guaranteed Analysis						Queensland Primary Dealer
	Percentage Nitrogen (N)	Percentage Phosphorus (P)	Percentage Potassium (K)	Percentage Miscellaneous	Percentage Fine	Percentage Coarse	

### ORGANIC FERTILIZERS—continued

#### MEATWORKS AND UREA

Garden King Blood and Bone Mixture	3.0 as blood, bone and offal 1.0 as urea	4.0 as bone	..	4.3 calcium (Ca) as bone	..	..	Consolidated Fertilizer Sales Pty. Ltd.
Hortico Blood and Bone Mixture	3.0 as blood, bone and offal 1.0 as urea	4.0 as bone	..	4.34 calcium (Ca) as bone	..	..	Hortico (Qld.) Pty. Ltd.

#### POULTRY MANURE

	As poultry manure	As poultry manure			As poultry manure				
		Water sol.	Citrate sol.	Insol.					
G.F. Dynamic Lifter	5.0	0.4	2.4	0.8	2.0	7.7 calcium (Ca) from poultry manure	1.0	99.0	General Fertilisers Limited

### INORGANIC FERTILIZERS

#### AMMONIUM NITRATE

ACF-Austral F.A.N. 34	As ammonium nitrate 17.0—ammonium form 17.0—nitrate form	..	..	..	..	..	..	..	Consolidated Fertilizer Sales Pty. Ltd.
ACF-Austral Nitram	17.0—ammonium form 17.0—nitrate form	..	..	..	..	..	..	..	ditto
Garden King Nitram	17.0—ammonium form 17.0—nitrate form	..	..	..	..	..	..	..	ditto
G. F. Nitram	17.0—ammonium form 17.0—nitrate form	..	..	..	..	..	..	..	General Fertilisers Ltd.

Name of Preparation	Guaranteed Analysis						Queensland Primary Dealer		
	Percentage Nitrogen (N)	Percentage Phosphorus (P)	Percentage Potassium (K)	Percentage Miscellaneous	Percentage Fine	Percentage Coarse			
<b>INORGANIC FERTILIZERS—continued</b>									
<b>AMMONIUM NITRATE MIXTURES</b>									
BASF Nitrogreen Calcium Ammonium nitrate	As ammonium nitrate 13.0—ammonium form 13.0—nitrate form	..	..	..	8.8 calcium (Ca) as calcium carbonate	..	..	BASF Australia Ltd.	
<b>AMMONIUM PHOSPHATE</b>									
	Ammonium form	Water sol.	Citrate sol.	Insol.					
Crop King D.A.P.	19.4	19.0	0.5	0.5	..	3.0 sulphur (S) as sulphates	..	..	Consolidated Fertilizer Sales Pty. Ltd.
Crop King D.A.P. 18	18.0	19.5	0.3	0.2	..	2.0 sulphur (S) as sulphates	..	..	ditto
Crop King Finely Ground M.A.P.	12.5	20.0	0.3	0.7	..	3.0 sulphur (S) as sulphates	..	..	ditto
Crop King M.A.P.	11.5	18.0	3.0	0.5	..	3.0 sulphur (S) as sulphates	..	..	ditto
G.F. D.A.P. ..	19.0	19.0	0.5	0.5	..	3.0 sulphur (S) as sulphates	..	..	General Fertilisers Ltd.
G.F. M.A.P. ..	12.0	17.5	2.5	0.5	..	2.5 sulphur (S) as sulphates	..	..	ditto
<b>AMMONIUM SULPHATE</b>									
ACF—Austral Sulphate of Ammonia	As ammonium sulphate 21.0	..	..	..	..	24.0 sulphur (S) as ammonium sulphate	..	..	Consolidated Fertilizer Sales Pty. Ltd.
Garden King Sulphate of Ammonia	21.0	..	..	..	..	24.0 sulphur (S) as ammonium sulphate	..	..	ditto
G.F. Sulphate of Ammonia	21.0	..	..	..	..	24.0 sulphur (S) as ammonium sulphate	..	..	General Fertilisers Ltd.
Hortico Sulphate of Ammonia	21.0	..	..	..	..	24.0 sulphur (S) as ammonium sulphate	..	..	Hortico (Qld.) Pty. Ltd.
Lane Sulphate of Ammonia	21.0	..	..	..	..	24.0 sulphur (S) as ammonium sulphate	..	..	Lane Ltd.
Lane's Sulphate of Ammonia	21.0	..	..	..	..	24.0 Sulphur (S) as ammonium sulphate	..	..	ditto



Name of Preparation	Guaranteed Analysis						Queensland Primary Dealer
	Percentage Nitrogen (N)	Percentage Phosphorus (P)	Percentage Potassium (K)	Percentage Miscellaneous	Percentage Fine	Percentage Coarse	

**INORGANIC FERTILIZERS—continued**

**ANHYDROUS AMMONIA**

Anhydrous Ammonia	As ammonia 82.0	..	..	..	..	..	Consolidated Fertilizer Sales Pty. Ltd. General Fertilisers Ltd.
G.F. Anhydrous Ammonia	82.0	..	..	..	..	..	

**AQUA AMMONIA**

Aqua Ammonia ..	As ammonia 20.5	..	..	..	..	..	Consolidated Fertilizer Sales Pty. Ltd. General Fertilisers Ltd.
G.F. Aqua Ammonia	20.5	..	..	..	..	..	

**POTASSIUM NITRATE**

Barmac Green-keeper Nitro	As potassium nitrate 13.6	..	As potassium nitrate 38.5	..	..	..	Barnes McGrath Pty. Ltd. Consolidated Fertilizer Sales Pty. Ltd.
ACF-Austral Potassium Nitrate	13.0	..	38.3	..	..	..	
Nitrate of Potash ..	13.6	..	38.5	..	..	..	Lane Ltd.

**POTASSIUM CHLORIDE**

ACF-Austral Muriate of Potash	..	..	As potassium chloride 50.0	..	..	..	Consolidated Fertilizer Sales Pty. Ltd. ditto
Garden King Fertilizer Muriate of Potash	..	..	50.0	..	..	..	
G.F. Muriate of Potash	..	..	50.0	..	..	..	General Fertilisers Ltd.

Name of Preparation	Guaranteed Analysis						Queensland Primary Dealer
	Percentage Nitrogen (N)	Percentage Phosphorus (P)	Percentage Potassium (K)	Percentage Miscellaneous	Percentage Fine	Percentage Coarse	
<b>INORGANIC FERTILIZERS—continued</b>							
<b>POTASSIUM SULPHATE</b>							
ACF—Austral "K" Spray	..	..	As potassium sulphate 42.0	17.0 sulphur (S) as potassium sulphate	..	..	Consolidated Fertilizer Sales Pty. Ltd.
ACF—Austral Sulphate of Potash	..	..	42.0	17.0 sulphur (S) as potassium sulphate	..	..	ditto
Garden King Sulphate of Potash	..	..	41.5	17.0 sulphur (S) as potassium sulphate	..	..	ditto
G.F. Sulphate of Potash	..	..	42.0	17.0 sulphur (S) as potassium sulphate	..	..	General Fertilisers Ltd.
Hortico Sulphate of Potash	..	..	41.5	18.4 sulphur (S) as potassium sulphate	..	..	Hortico (Qld.) Pty. Ltd.
<b>SODIUM NITRATE</b>							
ACF—Austral Nitrate of Soda	As sodium nitrate 16.0	..	..	..	..	..	Consolidated Fertilizer Sales Pty. Ltd.
<b>SUPERPHOSPHATE</b>							
		As superphosphate					
		Water sol.	Citrate sol.	Insol.			
ACF—Austral Processed Super	..	6.9	2.0	0.7	..	..	Consolidated Fertilizer Sales Pty. Ltd.
ACF—Austral Super	..	6.6	1.9	0.7	..	..	ditto
ACF—Austral Super King 18	..	14.0	2.5	1.5	..	..	ditto
					10.0 sulphur (S) as sulphates 20.0 calcium (Ca) as super 10.0 sulphur (S) as sulphates 20.0 calcium (Ca) as super 1.6 sulphur (S) as sulphates 16.0 calcium (Ca) as super		



Name of Preparation	Guaranteed Analysis						Queensland Primary Dealer
	Percentage Nitrogen (N)	Percentage Phosphorus (P)	Percentage Potassium (K)	Percentage Miscellaneous	Percentage Fine	Percentage Coarse	

### INORGANIC FERTILIZERS—continued

#### SUPERPHOSPHATE—continued

		As superphosphate								
		Water sol.	Citrate sol.	Insol.						
ACF—Austral Super King 19	..	14.0	3.5	1.7	..	1.6 sulphur (S) as sulphates 16.0 calcium (Ca) as super	..	..	Consolidated Fertilizer Sales Pty. Ltd.	
Crop King Double Super	..	14.0	2.2	1.3	..	4.5 sulphur (S) as sulphates 19.0 calcium (Ca) as super	..	..	ditto	
Garden King Superphosphate	..	7.4	1.1	1.1	..	10.0 sulphur (S) as sulphates 20.0 calcium (Ca) as super	..	..	ditto	
G.F. Granulated Superphosphate	..	6.6	1.9	0.7	..	10.0 sulphur (S) as sulphates 20.0 calcium (Ca) as super	..	..	General Fertilisers Ltd.	
G.F. Hi-P Super ..	..	14.0	3.5	1.7	..	1.5 sulphur (S) as sulphates 15.0 calcium (Ca) as super	..	..	ditto	
Hortico Superphosphate	..	7.6	1.0	0.8	..	10.0 sulphur (S) as sulphates 20.0 calcium (Ca) as super	..	..	Hortico (Qld.) Pty. Ltd.	
Lane Superphosphate	..	7.6	1.0	0.8	..	10.0 sulphur (S) as sulphates 20.0 calcium (Ca) as super	..	..	Lane Ltd.	
Lane's Superphosphate	..	7.4	1.1	1.1	..	10.0 sulphur (S) as sulphates 20.0 calcium (Ca) as super	..	..	ditto	

Name of Preparation	Guaranteed Analysis						Queensland Primary Dealer
	Percentage Nitrogen (N)	Percentage Phosphorus (P)	Percentage Potassium (K)	Percentage Miscellaneous	Percentage Fine	Percentage Coarse	

## INORGANIC FERTILIZERS—continued

### SUPERPHOSPHATE WITH TRACE ELEMENTS

		As superphosphate							
		Water sol.	Citrate sol.	Insol.					
ACF-Austral Super with Cu	..	6.4	1.8	0.7	..	9.6 sulphur (S) as sulphates 19.3 calcium (Ca) as super 0.9 copper (Cu) as copper sulphate	..	..	Consolidated Fertilizer Sales Pty. Ltd.
ACF-Austral Super with Cu, Zn, Mo	..	6.2	1.8	0.7	..	9.4 sulphur (S) as sulphates 18.8 calcium (Ca) as super 1.2 copper (Cu) as copper oxide 0.8 zinc (Zn) as zinc sulphate heptahydrate 0.03 molybdenum (Mo) as molybdenum trioxide	..	..	ditto
ACF-Austral Super with Mo 12	..	6.6	1.9	0.7	..	10.0 sulphur (S) as sulphates 19.9 calcium (Ca) as super 0.02 molybdenum (Mo) as molybdenum trioxide	..	..	ditto
ACF-Austral Super with Mo 18	..	6.6	1.9	0.7	..	19.9 calcium (Ca) as super 9.9 sulphur (S) as sulphates 0.03 molybdenum (Mo) as molybdenum trioxide	..	..	ditto



Name of Preparation	Guaranteed Analysis						Queensland Primary Dealer
	Percentage Nitrogen (N)	Percentage Phosphorus (P)	Percentage Potassium (K)	Percentage Miscellaneous	Percentage Fine	Percentage Coarse	

**INORGANIC FERTILIZERS—continued**  
**SUPERPHOSPHATE WITH TRACE ELEMENTS—continued**

		As superphosphate							
		Water sol.	Citrate sol.	Insol.					
ACF—Austral Super with Mo 24	..	6.5	1.9	0.7	..	19.9 calcium (Ca) as super 9.9 sulphur (S) as sulphates 0.04 molybdenum (Mo) as molybdenum trioxide	..	..	Consolidated Fertilizer Sales Pty. Ltd.
ACF—Austral Super with Sulphur	..	5.4	1.6	0.6	..	8.2 sulphur (S) as sulphates 17.5 sulphur (S) as elemental sulphur 16.4 calcium (Ca) as super	..	..	ditto
G.F. Granulated Superphosphate with Mo 12	..	6.5	1.9	0.7	..	20.0 calcium (Ca) as super 10.0 sulphur (S) as sulphates 0.02 molybdenum (Mo) as molybdenum trioxide	..	..	General Fertilisers Ltd.
G.F. Granulated Superphosphate with Mo 24	..	6.5	1.9	0.7	..	20.0 calcium (Ca) as super 10.0 sulphur (S) as sulphates 0.04 molybdenum (Mo) as molybdenum trioxide	..	..	ditto
G.F. Superphosphate + Copper	..	6.3	1.8	0.7	..	9.6 sulphur (S) as sulphates 19.2 calcium (Ca) as super 0.9 copper (Cu) as copper sulphate	..	..	ditto

Name of Preparation	Guaranteed Analysis						Queensland Primary Dealer
	Percentage Nitrogen (N)	Percentage Phosphorus (P)	Percentage Potassium (K)	Percentage Miscellaneous	Percentage Fine	Percentage Coarse	

### INORGANIC FERTILIZERS—continued

#### SUPERPHOSPHATE WITH TRACE ELEMENTS—continued

	..	As superphosphate			..		..	..	
		Water sol.	Citrate sol.	Insol.					
G.F. Superphosphate Cu, Zn, Mo	..	6.1	1.8	0.7	..	18.4 calcium (Ca) as super 9.2 sulphur (S) as sulphates 0.8 zinc (Zn) as zinc sulphate heptahydrate 1.2 copper (Cu) as copper oxide 0.03 molybdenum (Mo) as molybdenum trioxide	..	..	General Fertilisers Ltd.

#### UREA

	As urea							
Barmac Green-keeper Urea	46.0	..	..	..	2.0 maximum biuret	..	..	Barnes McGrath Pty. Ltd.
ACF-Austral U-Fine	46.0	..	..	..	1.0 maximum biuret	..	..	Consolidated Fertilizer Sales Pty. Ltd.
ACF-Austral N-Fine 44	44.0	..	..	..	1.0 maximum biuret	..	..	ditto
ACF-Austral Urea	46.0	..	..	..	1.0 maximum biuret	..	..	ditto
Garden King Urea	46.0	..	..	..	1.0 maximum biuret	..	..	ditto
G.F. Urea	46.0	..	..	..	1.0 maximum biuret	..	..	General Fertilisers Ltd.
Lane's Urea	46.0	..	..	..	0.5 maximum biuret	..	..	Lane Ltd.



Name of Preparation	Guaranteed Analysis						Queensland Primary Dealer
	Percentage Nitrogen (N)	Percentage Phosphorus (P)	Percentage Potassium (K)	Percentage Miscellaneous	Percentage Fine	Percentage Coarse	
<b>INORGANIC FERTILIZERS—continued</b>							
<b>UREA FORMALDEHYDE</b>							
Lane UF 38 (Urea Formaldehyde) Turf Fertilizer	As urea formaldehyde 38.0	..	..	..	..	..	Lane Ltd.
UF 38 (Urea Formaldehyde)	38.0	..	..	..	..	..	ditto
<b>UREA WITH TRACE ELEMENTS</b>							
ACF-Austral 42.37-0-0 with 4.7% Zinc	As urea 42.37	..	..	1.0 maximum biuret 4.7 zinc (Zn) as zinc oxide	..	..	Consolidated Fertilizer Sales Pty. Ltd.

### MIXED FERTILIZERS

The following mixtures are arranged according to the grade formula or N:P:K. This refers to the percentages of nitrogen (N), phosphorus (P) and potassium (K) contained in the mixture in that order, and it is usually shown on labels as three figures, for example, 3-0-5-0-15-0. The grade formulae have been arranged in order of increasing nitrogen content and in the case of mixtures containing similar quantities of nitrogen, in order of increasing phosphorus content.

Key to symbols used:—

a—ammonium sulphate (sulphate of ammonia)	m—meatworks (blood, bone and offal)	t—animal, bird, fish offal, marine organic, fowl and organic waste	w—poultry manure
b—bone	p—potassium sulphate	u—urea	x—potassium nitrate (nitrate of potash)
c—potassium chloride (muriate of potash)	s—superphosphate	v—vegetable meal	z—cottonseed meal
e—diammonium phosphate			

Grade Formula	Name of Preparation	Guaranteed Analysis											Queensland Primary Dealer
		Percentage Nitrogen (N) as			Percentage Phosphorus (P) as			Percentage Potassium (K)	Percentage Miscellaneous	Percentage Fine	Percentage Coarse		
		Nitrate Form	Ammonium Form	Other Forms	Water Sol. Form	Citrate Sol. Form	Insoluble Forms						
0-4-7-24-7	G.F. General Mix 3 ..	..	..	..	3.39	0.98	0.33	24.7c	10.4 calcium (Ca) as super sulphur sulphates	..	..	General Fertilisers Ltd.	
0-5-9-18-1	G.F. General Mix 2 Aldrin .08%	..	..	..	4.25	1.23	0.42	18.1c	12.2 calcium (Ca) as super sulphur sulphates	..	..	ditto	
0-6-0-18-0	G.F. General Mix 2 ..	..	..	..	4.32	1.25	0.43	18.0c	6.4 sulphur sulphates	..	..	ditto	
0-6-3-17-9	ACF-Austral Q2 ..	..	..	..	4.6	0.7	1.0	17.9c	12.9 calcium (Ca) as super sulphur sulphates	..	..	Consolidated Fertilizer Sales Pty. Ltd.	
0-7-8-8-3	ACF-Austral Q1 ..	..	..	..	5.6	1.6	0.6	8.3c	8.1 sulphur sulphates	..	..	ditto	
0-7-9-8-1	G.F. General Mix I ..	..	..	..	5.7	1.65	0.55	8.1c	16.3 calcium (Ca) as super sulphur sulphates	..	..	General Fertilisers Ltd.	



MIXED FERTILIZERS—continued

July—August 1977

Queensland Agricultural Journal

353

Grade Formula	Name of Preparation	Guaranteed Analysis											Queensland Primary Dealer
		Percentage Nitrogen (N) as			Percentage Phosphorus (P) as			Percentage Potassium (K)	Percentage Miscellaneous	Percentage Fine	Percentage Coarse		
		Nitrate Form	Ammonium Form	Other Forms	Water Sol. Form	Citrate Sol. Form	Insoluble Forms						
1.2—1.2—30.3	G.F. Pineapple Special copper and zinc	..	1.2	..	1.0	0.1	0.1	30.3p	3.0 calcium (Ca) as super sulphates 15.0 sulphur (S) as sulphates 0.4 copper (Cu) as copper sulphate 0.45 zinc (Zn) as zinc sulphate	..	..	General Fertilisers Ltd.	
1.5—4.9—20.0	G.F. King Leaf Tobacco 220	1.5	..	..	3.55	0.55	0.8	4.8x 15.2p	11.0 sulphur (S) as sulphates 9.5 calcium (Ca) as super sulphates	..	..	ditto	
2.3—5.0—16.5	G.F. 9 Special Gran Aldrin 0.08%	..	2.3	..	3.6	1.04	0.36	16.5c	7.9 sulphur (S) as sulphates 10.5 calcium (Ca) as super sulphates	..	..	ditto	
2.3—5.1—16.5	G.F.9 Special Gran ..	..	2.3	..	3.68	1.05	0.37	16.5c	0.08 aldrin 10.6 calcium (Ca) as super sulphates	..	..	ditto	
2.4—5.5—15.0	G.F. King Leaf Tobacco 315 + Mg	2.4	..	..	3.95	0.65	0.9	7.3x 7.7p	8.0 sulphur (S) as sulphates 11.0 calcium (Ca) as super sulphates	..	..	ditto	
2.4—6.0—15.0	G.F. King Leaf Tobacco 315	2.4	..	..	4.3	0.7	1.0	7.3x 7.7p	2.5 magnesium (Mg) as magnesium oxide 12.0 calcium (Ca) as super sulphates	..	..	ditto	
3.0—5.0—15.0	ACF—Austral Q9-1 ..	..	3.0	..	4.0	0.7	0.3	15.0c	9.1 sulphur (S) as sulphates 11.1 calcium (Ca) as super sulphates	..	..	Consolidated Fertilizer Sales Pty. Ltd.	
3.0—5.0—15.0	ACF—Austral Q9 (A.08)-1	..	3.0	..	4.0	0.7	0.3	15.0c	11.1 calcium (Ca) as super sulphates 9.1 sulphur (S) as sulphates	..	..	ditto	
3.0—5.2—15.0	G.F. 9 Special Gran (n)	..	3.0	..	4.0	0.6	0.6	15.0c	0.08 aldrin 11.0 calcium (Ca) as super sulphates	..	..	General Fertilisers Ltd.	
3.0—5.2—15.0	G.F. 9 Special Gran Aldrin 0.08% (n)	..	3.0	..	4.0	0.6	0.6	15.0c	9.0 sulphur (S) as sulphates 11.0 calcium (Ca) as super sulphates	..	..	ditto	
3.0—5.3—15.0	ACF—Austral Tobacco 315 Mg 2	3.0	..	..	3.8	1.1	0.4	6.7p 8.3x	0.08 aldrin 11.1 calcium (Ca) as super sulphates 8.2 sulphur (S) as sulphates 2.0 magnesium (Mg) as magnesium oxide	..	..	Consolidated Fertilizer Sales Pty. Ltd.	

## MIXED FERTILIZERS—continued

Grade Formula	Name of Preparation	Guaranteed Analysis										Queensland Primary Dealer
		Percentage Nitrogen (N) as			Percentage Phosphorus (P) as			Percentage Potassium (K)	Percentage Miscellaneous	Percentage Fine	Percentage Coarse	
		Nitrate Form	Ammonium Form	Other Forms	Water Sol. Form	Citrate Sol. Form	Insoluble Forms					
3-0-5.4-15.0	ACF-Austral Q9 ..	..	3.0	..	3.9	0.6	0.9	15.0c	11.0 calcium (Ca) as super sulphur (S) as sulphates	..	..	Consolidated Fertilizer Sales Pty. Ltd.
3-0-5.4-15.0	ACF-Austral Q9 (A.08)	..	3.0	..	3.9	0.6	0.9	15.0c	11.0 calcium (Ca) as super sulphur (S) as sulphates	..	..	ditto
3.1-5.6-15.6	ACF-Austral Tobacco 315	3.1	..	..	4.0	1.2	0.4	7.0p	11.6 calcium (Ca) as super sulphur (S) as sulphates	..	..	ditto
3.15-7.7-5.0	G.F. King Leaf Tobacco 405	1.75	1.4	..	5.6	0.9	1.2	5.0x	15.0 calcium (Ca) as super sulphur (S) as sulphates	..	..	General Fertilisers Ltd.
3.2-6.4-1.6	Yates Rose Food ..	..	..	1.8u 0.45v 0.95m	1.5	1.28	3.65	1.5c 0.1p	4.4 calcium (Ca) as super sulphur (S) as sulphates	70.0	30.0	Arthur Yates & Co. Pty. Ltd.
4.0-3.0-0	G.F. B & B. Organic ..	..	..	0.9t 0.3m 2.8u 0.3t 0.3m 3.4u	..	..	3.0	..	5.8 calcium (Ca) as blood and bone and calcined phosphate	..	..	General Fertilisers Ltd.
4.0-3.0-1.0	Gro-Wel Organic and Mineral Fertilizer	..	..	..	..	..	3.0	1.0p	..	..	..	Acacia Nurseries
4.0-3.8-29.8	G.F. Top Crop 37 ..	..	2.85	1.15w	2.89	0.65	0.26	0.4w 29.4c	1.9 calcium (Ca) as poultry manure (S) as sulphates	1.0	99.0	General Fertilisers Ltd.
4.0-4.0-0	Lane Organic Fertilizer ..	..	..	2.5t 0.5m 1.0u	..	0.9	3.1	..	1.0 calcium (Ca) as blood and bone (Ca) as calcined phosphate	..	..	Lane Ltd.
4.0-6.5-0.9	Garden King Rose and Seedling Food	..	..	4.0z	..	1.3	5.2	0.9z	11.5 calcium (Ca) as bone and rock phosphate	85.0	15.0	Consolidated Fertilizer Sales Pty. Ltd.
4.0-6.8-4.0	Hortico Vegetable Planter and Feeder	..	4.0a	..	5.54s	0.73s	0.59s	4.0c	14.6 calcium (Ca) as super sulphur (S) as sulphates	..	..	Hortico (Qld.) Pty. Ltd.
4.05-4.8-12.5	G.F. 2 Organic .. ..	..	3.1	0.6w 0.35b	2.36	0.94	1.5	0.25w 12.25c	7.9 calcium (Ca) as bone and superphosphate (Ca) as poultry manure (S) as sulphates	30.0	70.0	General Fertilisers Ltd.
4.1-4.2-20.9	ACF-Austral Tobacco 420	4.1	..	..	3.0	0.9	0.3	9.4p 11.5x	8.5 calcium (Ca) as super sulphur (S) as sulphates	..	..	Consolidated Fertilizer Sales Pty. Ltd.



MIXED FERTILIZERS—continued

July—August 1977

Queensland Agricultural Journal

355

Grade Formula	Name of Preparation	Guaranteed Analysis											Queensland Primary Dealer
		Percentage Nitrogen (N) as			Percentage Phosphorus (P) as			Percentage Potassium (K)	Percentage Miscellaneous	Percentage Fine	Percentage Coarse		
		Nitrate Form	Ammonium Form	Other Forms	Water Sol. Form	Citrate Sol. Form	Insoluble Forms						
4-1-4-3-32-2	G.F. Hi-Blend 4-4-32 Organic Aldrin .08%	..	3.5	0.6w	3.67	0.4	0.23	0.2w 32.0c	0.9 calcium (Ca) as poultry manure 0.5 calcium (Ca) as super 0.85 sulphur (S) as sulphates 0.08 aldrin	87.0	13.0	General Fertilisers Ltd.	
4-1-4-4-32-2	G.F. Hi-Blend 4-4-32 Organic	..	3.5	0.6w	3.76	0.4	0.24	0.2w 32.0c	0.9 calcium (Ca) as poultry manure 0.7 calcium (Ca) as super 0.93 sulphur (S) as sulphates	87.0	13.0	ditto	
4-1-5-0-24-0	G.F. Hi-Blend 4-5-24 Organic Aldrin .08%	..	3.5	0.6w	4.01	0.69	0.3	0.2w 23.8c	0.9 calcium (Ca) as poultry manure 3.7 calcium (Ca) as super 3.1 sulphur (S) as sulphates 0.08 aldrin	..	..	ditto	
4-1-5-1-24-2	G.F. Hi-Blend 4-5-24 Organic	..	3.5	0.6w	4.1	0.7	0.3	0.2w 24.0c	0.9 calcium (Ca) as poultry manure 3.8 calcium (Ca) as super 3.2 sulphur (S) as sulphates	87.0	13.0	ditto	
4-3-5-7-6-2	G.F. 4 Organic Boron .24%	..	3.35	0.6w 0.35b	3.01	1.13	1.56	0.25w 5.95c	0.9 calcium (Ca) as poultry manure 10.1 calcium (Ca) as superphosphate and bone 8.7 sulphur (S) as sulphates 0.24 boron (B) as sodium borate	30.0	70.0	ditto	
4-5-4-7-37-1	Crop King 22 .. ..	..	4.5	..	4.5	0.1	0.1	37.1c	0.7 sulphur (S) as sulphates	..	..	Consolidated Fertilizer Sales Pty. Ltd.	
4-5-4-7-37-1	G.F. Hi-Blend 4-4-37 .. ..	..	4.5	..	4.5	0.1	0.1	37.1c	0.7 sulphur (S) as sulphates	..	..	General Fertilisers Ltd.	
4-5-4-7-37-1	G.F. Hi-Blend 4-4-37 (n) .. ..	..	4.5	..	4.5	0.1	0.1	37.1c	0.7 sulphur (S) as sulphates	..	..	ditto	
4-5-4-7-37-2	Crop King 33-1 .. ..	..	4.5	..	4.5	0.1	0.1	37.2c	0.7 sulphur (S) as sulphates	..	..	Consolidated Fertilizer Sales Pty. Ltd.	
4-5-5-8-6-2	G.F. 4 Organic .. ..	..	3.55	0.6w 0.35b	3.08	1.16	1.56	0.25w 5.95c	8.0 calcium (Ca) as superphosphate and bone 0.9 calcium (Ca) as poultry manure 10.8 sulphur (S) as sulphates	30.0	70.0	General Fertilisers Ltd.	
4-6-1-5-29-1	G.F. Sugar Bureau 4 .. ..	..	4.6	..	1.09	0.31	0.11	29.1c	3.0 calcium (Ca) as super 7.0 sulphur (S) as sulphates	..	..	ditto	

## MIXED FERTILIZERS—continued

Grade Formula	Name of Preparation	Guaranteed Analysis											Queensland Primary Dealer
		Percentage Nitrogen (N) as			Percentage Phosphorus (P) as			Percentage Potassium (K)	Percentage Miscellaneous	Percentage Fine	Percentage Coarse		
		Nitrate Form	Ammonium Form	Other Forms	Water Sol. Form	Citrate Sol. Form	Insoluble Forms						
4-6-1.5-29.1	G.F. Sugar Bureau 4 Aldrin 0.08%	..	4.6	..	1.09	0.31	0.10	29.1c	3.0 calcium (Ca) as super sulphur (S) as sulphates 0.08 aldrin	..	..	General Fertilisers Ltd.	
4-6-5.6-4.1	Garden King Fish 4 ..	..	3.2	0.35u 1.05m	2.2	1.0	2.4	4.1p	8.0 calcium (Ca) as super sulphur (S) as sulphates 1.4 calcium (Ca) as bone	..	..	Consolidated Fertilizer Sales Pty. Ltd.	
4-6-5.6-4.1	Garden King Rose Fertilizer	..	3.2	0.35u 1.05m	2.2	1.0	2.4	4.1p	8.0 calcium (Ca) as super sulphur (S) as sulphates 1.4 calcium (Ca) as bone	..	..	ditto	
4-6-6.2-4.05	G.F. 4 Gran Boron .3 ..	..	4.63	..	4.47	1.28	0.45	4.05c	12.8 calcium (Ca) as superphosphate 11.8 sulphur (S) as sulphates 0.3 boron (B) as sodium borate	..	..	General Fertilisers Ltd.	
4.7-6.5-3.7	ACF-Austral Q5 (S) ..	..	4.7	..	4.6	1.3	0.5	3.7p	13.3 calcium (Ca) as super sulphur (S) as sulphates 13.6 sulphur (S) as sulphates	..	..	Consolidated Fertilizer Sales Pty. Ltd.	
4.9-6.3-3.9	ACF-Austral Q5 Boron	..	4.9	..	4.8	0.7	1.2	3.9c	12.4 sulphur (S) as sulphates 13.5 calcium (Ca) as super sulphur (S) as sulphates 0.3 boron (B) as sodium borate	..	..	ditto	
5.0-5.0-25.0	G.F. Hi-Blend 5-5-25 ..	..	5.0	..	4.28	0.51	0.21	25.0c	4.5 calcium (Ca) as super sulphur (S) as sulphates 5.4 sulphur (S) as sulphates	..	..	General Fertilisers Ltd.	
5.0-5.0-25.0	G.F. Hi-Blend 5-5-25 Aldrin 0.08%	..	5.0	..	4.27	0.51	0.22	25.0c	4.4 calcium (Ca) as super sulphur (S) as sulphates 5.3 sulphur (S) as sulphates 0.08 aldrin	..	..	ditto	
5.0-5.6-8.0	ACF-Austral Q3 ..	..	5.0	..	4.4	0.6	0.6	8.0c	12.0 calcium (Ca) as super sulphur (S) as sulphates 11.7 sulphur (S) as sulphates	..	..	Consolidated Fertilizer Sales Pty. Ltd.	
5.0-5.6-8.0	ACF-Austral Q3 (A.06)	..	5.0	..	4.4	0.6	0.6	8.0c	12.0 calcium (Ca) as super sulphur (S) as sulphates 11.7 sulphur (S) as sulphates 0.06 aldrin	..	..	ditto	



MIXED FERTILIZERS—continued

Grade Formula	Name of Preparation	Guaranteed Analysis												Queensland Primary Dealer
		Percentage Nitrogen (N) as			Percentage Phosphorus (P) as			Percentage Potassium (K)	Percentage Miscellaneous	Percentage Fine	Percentage Coarse			
		Nitrate Form	Ammonium Form	Other Forms	Water Sol. Form	Citrate Sol. Form	Insoluble Forms							
5-0-5-8-4-4	G.F. Top Crop 15 .. ..	..	2-97	1-25w 0-78b	1-9	1-1	2-8	3-9c 0-5w	1-8 calcium (Ca) as poultry manure 7-4 calcium (Ca) as superphosphate and bone 6-2 sulphur (S) as sulphates 13-8 calcium (Ca) as super 12-6 sulphur (S) as sulphates 13-5 calcium (Ca) as super 13-0 sulphur (S) as sulphates 13-5 calcium (Ca) as super 13-0 sulphur (S) as sulphates 13-7 calcium (Ca) as super 0-08 aldrin 13-3 calcium (Ca) as super 6-7 sulphur (S) as sulphates 0-1 maximum biuret 13-7 calcium (Ca) as super 12-5 sulphur (S) as sulphates 0-08 aldrin 13-6 calcium (Ca) as super 11-5 sulphur (S) as sulphates 10-9 calcium (Ca) as super 5-8 sulphur (S) as sulphates 4-7 calcium (Ca) as superphosphate and bone 1-9 calcium (Ca) as poultry manure 1-8 sulphur (S) as sulphates	30-0	70-0	General Fertilisers Ltd.		
5-0-6-1-4-0	ACF-Austral Q5-1 .. ..	..	5-0	..	5-0	0-9	0-2	4-0c	12-5 sulphur (S) as sulphates 13-8 calcium (Ca) as super 12-6 sulphur (S) as sulphates 13-5 calcium (Ca) as super 13-0 sulphur (S) as sulphates 13-5 calcium (Ca) as super 13-0 sulphur (S) as sulphates 13-7 calcium (Ca) as super 0-08 aldrin 13-3 calcium (Ca) as super 6-7 sulphur (S) as sulphates 0-1 maximum biuret 13-7 calcium (Ca) as super 12-5 sulphur (S) as sulphates 0-08 aldrin 13-6 calcium (Ca) as super 11-5 sulphur (S) as sulphates 10-9 calcium (Ca) as super 5-8 sulphur (S) as sulphates 4-7 calcium (Ca) as superphosphate and bone 1-9 calcium (Ca) as poultry manure 1-8 sulphur (S) as sulphates	..	..	Consolidated Fertilizer Sales Pty. Ltd.		
5-0-6-2-4-0	Lane Market Garden Manure .. ..	..	5-0	..	5-0	0-6	0-6	4-0c	12-5 sulphur (S) as sulphates 13-8 calcium (Ca) as super 12-6 sulphur (S) as sulphates 13-5 calcium (Ca) as super 13-0 sulphur (S) as sulphates 13-5 calcium (Ca) as super 13-0 sulphur (S) as sulphates 13-7 calcium (Ca) as super 0-08 aldrin 13-3 calcium (Ca) as super 6-7 sulphur (S) as sulphates 0-1 maximum biuret 13-7 calcium (Ca) as super 12-5 sulphur (S) as sulphates 0-08 aldrin 13-6 calcium (Ca) as super 11-5 sulphur (S) as sulphates 10-9 calcium (Ca) as super 5-8 sulphur (S) as sulphates 4-7 calcium (Ca) as superphosphate and bone 1-9 calcium (Ca) as poultry manure 1-8 sulphur (S) as sulphates	..	..	Lane Ltd.		
5-0-6-2-4-0	Lane Tomato Fertilizer .. ..	..	5-0	..	5-0	0-6	0-6	4-0c	12-5 sulphur (S) as sulphates 13-8 calcium (Ca) as super 12-6 sulphur (S) as sulphates 13-5 calcium (Ca) as super 13-0 sulphur (S) as sulphates 13-5 calcium (Ca) as super 13-0 sulphur (S) as sulphates 13-7 calcium (Ca) as super 0-08 aldrin 13-3 calcium (Ca) as super 6-7 sulphur (S) as sulphates 0-1 maximum biuret 13-7 calcium (Ca) as super 12-5 sulphur (S) as sulphates 0-08 aldrin 13-6 calcium (Ca) as super 11-5 sulphur (S) as sulphates 10-9 calcium (Ca) as super 5-8 sulphur (S) as sulphates 4-7 calcium (Ca) as superphosphate and bone 1-9 calcium (Ca) as poultry manure 1-8 sulphur (S) as sulphates	..	..	ditto		
5-0-6-4-4-0	G.F. 4 Gran n .. ..	..	5-0	..	5-0	0-7	0-7	4-0c	12-5 sulphur (S) as sulphates 13-8 calcium (Ca) as super 12-6 sulphur (S) as sulphates 13-5 calcium (Ca) as super 13-0 sulphur (S) as sulphates 13-5 calcium (Ca) as super 13-0 sulphur (S) as sulphates 13-7 calcium (Ca) as super 0-08 aldrin 13-3 calcium (Ca) as super 6-7 sulphur (S) as sulphates 0-1 maximum biuret 13-7 calcium (Ca) as super 12-5 sulphur (S) as sulphates 0-08 aldrin 13-6 calcium (Ca) as super 11-5 sulphur (S) as sulphates 10-9 calcium (Ca) as super 5-8 sulphur (S) as sulphates 4-7 calcium (Ca) as superphosphate and bone 1-9 calcium (Ca) as poultry manure 1-8 sulphur (S) as sulphates	..	..	General Fertilisers Ltd.		
5-0-6-4-4-0	G.F. 4 Gran (n) Aldrin 0-08% .. ..	..	5-0	..	5-0	0-7	0-7	4-0c	12-5 sulphur (S) as sulphates 13-8 calcium (Ca) as super 12-6 sulphur (S) as sulphates 13-5 calcium (Ca) as super 13-0 sulphur (S) as sulphates 13-5 calcium (Ca) as super 13-0 sulphur (S) as sulphates 13-7 calcium (Ca) as super 0-08 aldrin 13-3 calcium (Ca) as super 6-7 sulphur (S) as sulphates 0-1 maximum biuret 13-7 calcium (Ca) as super 12-5 sulphur (S) as sulphates 0-08 aldrin 13-6 calcium (Ca) as super 11-5 sulphur (S) as sulphates 10-9 calcium (Ca) as super 5-8 sulphur (S) as sulphates 4-7 calcium (Ca) as superphosphate and bone 1-9 calcium (Ca) as poultry manure 1-8 sulphur (S) as sulphates	..	..	ditto		
5-0-6-4-10-3	Crop King 99 .. ..	..	..	5-0u	4-6	1-3	0-5	10-3c	12-5 sulphur (S) as sulphates 13-8 calcium (Ca) as super 12-6 sulphur (S) as sulphates 13-5 calcium (Ca) as super 13-0 sulphur (S) as sulphates 13-5 calcium (Ca) as super 13-0 sulphur (S) as sulphates 13-7 calcium (Ca) as super 0-08 aldrin 13-3 calcium (Ca) as super 6-7 sulphur (S) as sulphates 0-1 maximum biuret 13-7 calcium (Ca) as super 12-5 sulphur (S) as sulphates 0-08 aldrin 13-6 calcium (Ca) as super 11-5 sulphur (S) as sulphates 10-9 calcium (Ca) as super 5-8 sulphur (S) as sulphates 4-7 calcium (Ca) as superphosphate and bone 1-9 calcium (Ca) as poultry manure 1-8 sulphur (S) as sulphates	..	..	Consolidated Fertilizer Sales Pty. Ltd.		
5-0-6-8-4-0	ACF-Austral Q5 (A-08) .. ..	..	5-0	..	4-8	0-8	1-2	4-0c	12-5 sulphur (S) as sulphates 13-8 calcium (Ca) as super 12-6 sulphur (S) as sulphates 13-5 calcium (Ca) as super 13-0 sulphur (S) as sulphates 13-5 calcium (Ca) as super 13-0 sulphur (S) as sulphates 13-7 calcium (Ca) as super 0-08 aldrin 13-3 calcium (Ca) as super 6-7 sulphur (S) as sulphates 0-1 maximum biuret 13-7 calcium (Ca) as super 12-5 sulphur (S) as sulphates 0-08 aldrin 13-6 calcium (Ca) as super 11-5 sulphur (S) as sulphates 10-9 calcium (Ca) as super 5-8 sulphur (S) as sulphates 4-7 calcium (Ca) as superphosphate and bone 1-9 calcium (Ca) as poultry manure 1-8 sulphur (S) as sulphates	..	..	Consolidated Fertilizer Sales Pty. Ltd.		
5-0-7-3-4-0	Garden King Q5 .. ..	..	5-0	..	3-8	1-8	1-7	4-0c	12-5 sulphur (S) as sulphates 13-8 calcium (Ca) as super 12-6 sulphur (S) as sulphates 13-5 calcium (Ca) as super 13-0 sulphur (S) as sulphates 13-5 calcium (Ca) as super 13-0 sulphur (S) as sulphates 13-7 calcium (Ca) as super 0-08 aldrin 13-3 calcium (Ca) as super 6-7 sulphur (S) as sulphates 0-1 maximum biuret 13-7 calcium (Ca) as super 12-5 sulphur (S) as sulphates 0-08 aldrin 13-6 calcium (Ca) as super 11-5 sulphur (S) as sulphates 10-9 calcium (Ca) as super 5-8 sulphur (S) as sulphates 4-7 calcium (Ca) as superphosphate and bone 1-9 calcium (Ca) as poultry manure 1-8 sulphur (S) as sulphates	..	..	ditto		
5-0-7-5-10-0	G.F. Tomato Special .. ..	..	5-0	..	5-9	0-68	0-92	10-0c	12-5 sulphur (S) as sulphates 13-8 calcium (Ca) as super 12-6 sulphur (S) as sulphates 13-5 calcium (Ca) as super 13-0 sulphur (S) as sulphates 13-5 calcium (Ca) as super 13-0 sulphur (S) as sulphates 13-7 calcium (Ca) as super 0-08 aldrin 13-3 calcium (Ca) as super 6-7 sulphur (S) as sulphates 0-1 maximum biuret 13-7 calcium (Ca) as super 12-5 sulphur (S) as sulphates 0-08 aldrin 13-6 calcium (Ca) as super 11-5 sulphur (S) as sulphates 10-9 calcium (Ca) as super 5-8 sulphur (S) as sulphates 4-7 calcium (Ca) as superphosphate and bone 1-9 calcium (Ca) as poultry manure 1-8 sulphur (S) as sulphates	..	..	General Fertilisers Ltd.		
5-0-7-7-10-2	G.F. Top Crop 16 .. ..	..	3-07	1-15w 0-78b	4-1	1-6	2-0	0-3w 9-9c	12-5 sulphur (S) as sulphates 13-8 calcium (Ca) as super 12-6 sulphur (S) as sulphates 13-5 calcium (Ca) as super 13-0 sulphur (S) as sulphates 13-5 calcium (Ca) as super 13-0 sulphur (S) as sulphates 13-7 calcium (Ca) as super 0-08 aldrin 13-3 calcium (Ca) as super 6-7 sulphur (S) as sulphates 0-1 maximum biuret 13-7 calcium (Ca) as super 12-5 sulphur (S) as sulphates 0-08 aldrin 13-6 calcium (Ca) as super 11-5 sulphur (S) as sulphates 10-9 calcium (Ca) as super 5-8 sulphur (S) as sulphates 4-7 calcium (Ca) as superphosphate and bone 1-9 calcium (Ca) as poultry manure 1-8 sulphur (S) as sulphates	..	..	ditto		

## MIXED FERTILIZERS—continued

Grade Formula	Name of Preparation	Guaranteed Analysis											Queensland Primary Dealer
		Percentage Nitrogen (N) as			Percentage Phosphorus (P) as			Percentage Potassium (K)	Percentage Miscellaneous	Percentage Fine	Percentage Coarse		
		Nitrate Form	Ammonium Form	Other Forms	Water Sol. Form	Citrate Sol. Form	Insoluble Forms						
5-0-7-8-10-2	G.F. Tomato Special Containing Organic Materials	..	4.4	0.6w	6.04	0.87	0.9	0.2w 10.0c	0.9 calcium (Ca) as poultry manure 8.7 calcium (Ca) as super 6.7 sulphur (S) as sulphates 12.7 calcium (Ca) as super 12.4 sulphur (S) as sulphates 0.08 aldrin	87.0	13.0	General Fertilisers Ltd.	
5-1-6-2-4-1	G.F. 4 Gran Aldrin 0.08%	..	5.1	..	4.46	1.29	0.45	4.1c	12.4 sulphur (S) as sulphates 13.1 calcium (Ca) as super 12.4 sulphur (S) as sulphates	..	..	ditto	
5-1-6-3-3-9	ACF-Austral Q5 .. ..	..	5.1	..	4.5	1.3	0.5	3.9c	13.8 calcium (Ca) as super 12.8 sulphur (S) as sulphates	..	..	Consolidated Fertilizer Sales Pty. Ltd.	
5-1-6-7-1-5	G.F. Bean Mix .. ..	..	5.1	..	4.82	1.39	0.49	1.5c	13.0 calcium (Ca) as super 12.4 sulphur (S) as sulphates	..	..	General Fertilisers Ltd.	
5-2-6-1-5-0	Hortico Lawn Starter .. ..	..	5.2a	..	4.84s	0.7s	0.56s	5.0c	13.0 calcium (Ca) as super 12.4 sulphur (S) as sulphates	..	..	Hortico (Qld.) Pty. Ltd.	
5-2-6-2-4-2	G.F. 4 Gran .. ..	..	5.2	..	4.46	1.29	0.45	4.2c	12.7 calcium (Ca) as super 12.4 sulphur (S) as sulphates	..	..	General Fertilisers Ltd.	
5-3-3-3-16.4	G.F. Grape Special Organic boron 0.24%	..	4.36	0.6w 0.34b	1.24	0.63	1.43	0.2w 16.2c	0.9 calcium (Ca) as poultry manure 4.4 calcium (Ca) as super and bone 6.8 sulphur (S) as sulphates 0.24 boron (B) as sodium borate	30.0	70.0	ditto	
5-3-3-3-17.5	G.F. Grape Special Organic	..	4.36	0.6w 0.34b	1.24	0.63	1.43	0.2w 17.3c	0.9 calcium (Ca) as poultry manure 4.4 calcium (Ca) as super and bone 6.8 sulphur (S) as sulphates	30.0	70.0	ditto	
6-1-4-1-33.5	G.F. Hi-Blend 6-4-33 Aldrin 0.08%	..	6.1	..	3.9	0.1	0.1	33.5c	0.08 aldrin 3.0 sulphur (S) as sulphates	..	..	ditto	
6-2-4-1-33.5	G.F. Hi-Blend 6-4-33 .. ..	..	6.2	..	3.9	0.1	0.1	33.5c	3.1 sulphur (S) as sulphates	..	..	ditto	
6-2-6-0-24.2	G.F. Top Crop 36 .. ..	..	5.05	1.15w	5.0	0.7	0.3	0.4 w 23.8c	1.9 calcium (Ca) as poultry manure 0.7 sulphur (S) as sulphates	1.0	99.0	ditto	
6-3-1.6-24.5	G. F. King Banana Organic	..	5.35	0.6 w 0.35b	0.04	0.24	1.32	0.25w 24.25c	0.9 calcium (Ca) as poultry manure 0.9 calcium (Ca) as bone 6.0 sulphur (S) as sulphates	30.0	70.0	ditto	



MIXED FERTILIZERS—continued

July—August 1977

Queensland Agricultural Journal

359

Grade Formula	Name of Preparation	Guaranteed Analysis											Queensland Primary Dealer
		Percentage Nitrogen (N) as			Percentage Phosphorus (P) as			Percentage Potassium (K)	Percentage Miscellaneous	Percentage Fine	Percentage Coarse		
		Nitrate Form	Ammonium Form	Other Forms	Water Sol. Form	Citrate Sol. Form	Insoluble Forms						
6.3—6.6—32.5	Crop King 33 .. ..	..	6.3	..	6.3	0.2	0.1	32.5c	1.0 sulphur (S) as sulphates	..	..	Consolidated Fertilizer Sales Pty. Ltd.	
6.3—6.6—32.5	G.F. Hi-Blend 6-6-32 ..	..	6.3	..	6.28	0.16	0.16	32.5c	0.1 sulphur (S) as sulphates	..	..	General Fertilisers Ltd.	
6.8—4.0—10.0	G.F. 16 Banana Organic	..	5.85	0.6 w 0.35b	1.78	0.79	1.43	0.25w 9.75c	0.9 calcium (Ca) as poultry manure 6.2 calcium (Ca) as superphosphate and bone 9.4 sulphur (S) as sulphates	30.0	70.0	ditto	
6.8—6.3—7.4	A.C.N. Garden Fertiliser	..	..	6.8u	5.2	0.55	0.55	7.4p	13.0 calcium (Ca) as super 6.0 sulphur (S) as super 3.0 sulphur (S) as sulphates	..	..	Acacia Nurseries	
7.0—4.0—12.2	Hortico Fruit and Citrus Food	..	7.0a	..	3.22s	0.43s	0.35s	12.2c	8.5 calcium (Ca) as super 12.1 sulphur (S) as sulphates	..	..	Hortico (Qld.) Pty. Ltd.	
7.0—4.4—10.0	Hortico Rose Food ..	..	7.0a	..	3.55s	0.47s	0.38s	10.0c	9.4 calcium (Ca) as super 12.6 sulphur (S) as sulphates	..	..	ditto	
7.0—7.2—26.1	G.F. Hi-Blend 7-7-26 Organic Aldrin 0.08%	..	6.43	0.57w	6.51	0.43	0.26	0.2w 25.9c	0.9 calcium (Ca) as poultry manure 1.0 sulphur (S) as sulphates	87.0	13.0	General Fertilisers Ltd.	
7.1—7.3—26.2	G.F. Hi-Blend 7-7-26 Organic	..	6.5	0.6w	6.6	0.44	0.26	0.2w 26.0c	0.9 calcium (Ca) as poultry manure 0.9 sulphur (S) as sulphates	87.0	13.0	ditto	
7.4—3.6—4.9	Yates Tomato Food ..	..	5.88	1.2u 0.4m	1.5	0.57	1.62	4.98c	4.4 calcium (Ca) as super 9.46 sulphur (S) as sulphates	60.0	40.0	Arthur Yates & Co. Pty. Ltd.	
8.0—7.0—26.1	G.F. Hi-Blend 8-7-26 ..	..	8.0	..	6.58	0.24	0.18	26.1c	0.4 magnesium (Mg) as magnesium sulphate 0.8 calcium (Ca) as super 3.6 sulphur (S) as sulphates	..	..	General Fertilisers Ltd.	
8.0—7.0—26.1	G.F. Hi-Blend 8-7-26 Aldrin 0.08%	..	8.0	..	6.58	0.24	0.18	26.1c	0.8 calcium (Ca) as super 3.5 sulphur (S) as sulphates	..	..	ditto	
8.0—7.1—26.1	G.F. Hi-Blend 8-7-26 copper 1.2%	..	8.0	..	6.74	0.18	0.18	26.1c	0.08 aldrin 2.3 sulphur (S) as sulphates 1.2 copper (Cu) as copper sulphate	..	..	ditto	

## MIXED FERTILIZERS—continued

Grade Formula	Name of Preparation	Guaranteed Analysis											Queensland Primary Dealer
		Percentage Nitrogen (N) as			Percentage Phosphorus (P) as			Percentage Potassium (K)	Percentage Miscellaneous	Percentage Fine	Percentage Coarse		
		Nitrate Form	Ammonium Form	Other Forms	Water Sol. Form	Citrate Sol. Form	Insoluble Forms						
8-3-10-0-7-8	G.F. Top Crop 18 Aldrin .08%	..	6.37	1.15w 0.78b	6.38	0.74	2.88	0.4w 7.4c	1.9 calcium (Ca) as poultry manure 2.0 calcium (Ca) as bone 1.0 sulphur (S) as sulphates 0.08 aldrin	30.0	70.0	General Fertilisers Ltd.	
8-4-8-8-25.5	Crop King 44 with Cu 1.8	..	8.4	..	8.4	0.2	0.2	25.5c	1.3 sulphur (S) as sulphates 1.8 copper (Cu) as copper oxide	..	..	Consolidated Fertilizer Sales Pty. Ltd.	
8-4-10-1-8-1	G.F. Top Crop 18 ..	..	6.47	1.15w 0.78b	6.48	0.74	2.88	0.4w 7.7c	1.9 calcium (Ca) as poultry manure 2.0 calcium (Ca) as bone 1.0 sulphur (S) as sulphates	30.0	70.0	General Fertilisers Ltd.	
8-7-1.5-16.5	G.F. Top Crop 26 ..	..	7.37	1.15w 0.18b	0.1	0.55	0.85	0.4w 16.1c	1.9 calcium (Ca) as poultry manure 0.5 calcium (Ca) as bone 8.3 sulphur (S) as sulphates	20.0	80.0	ditto	
8-7-8-9-26.4	Crop King 44-1 ..	..	8.7	..	8.5	0.2	0.2	26.4c	1.3 sulphur (S) as sulphates	..	..	Consolidated Fertilizer Sales Pty. Ltd.	
8-7-8-9-26.4	Crop King 44 (A-08)-1	..	8.7	..	8.5	0.2	0.2	26.4c	1.3 sulphur (S) as sulphates	..	..	ditto	
8-7-9-1-26.2	Crop King 44 ..	..	8.7	..	8.7	0.2	0.2	26.2c	0.08 aldrin 1.4 sulphur (S) as sulphates	..	..	ditto	
8-7-9-1-26.2	Crop King 44 (A-08)	..	8.7	..	8.7	0.2	0.2	26.2c	1.4 sulphur (S) as sulphates 0.08 aldrin	..	..	ditto	
8-7-9-1-26.2	G.F. Hi-Blend 8-9-26	..	8.7	..	8.66	0.22	0.22	26.2c	1.3 sulphur (S) as sulphates	..	..	General Fertilisers Ltd.	
8-7-9-1-26.2	G.F. Hi-Blend 8-9-26 (n)	..	8.7	..	8.7	0.2	0.2	26.2c	1.4 sulphur (S) as sulphates	..	..	ditto	
8-7-9-1-26.2	G.F. Hi-Blend 8-9-26 Aldrin .08% (n)	..	8.7	..	8.7	0.2	0.2	26.2c	1.4 sulphur (S) as sulphates 0.08% aldrin	..	..	ditto	
8-8-2.1-15.2	G.F. 10 Organic ..	..	7.85	0.6w 0.35b	0.41	0.38	1.31	0.25w 14.95c	0.9 calcium (Ca) as poultry manure 2.0 calcium (Ca) as superphosphate and bone 9.6 sulphur (S) as sulphates	30.0	70.0	ditto	
8-8-4.4-25.2	Crop King Tobacco 8 Mg6	4.6	4.2	..	4.2	0.1	0.1	12.2p 13.0x	5.6 sulphur (S) as sulphates 6.0 magnesium (Mg) as magnesium oxide	..	..	Consolidated Fertilizer Sales Pty. Ltd.	
9.0-10.2-16.2	G.F. Hi-Blend 9-10-16 Organic Aldrin .08%	..	8.4	0.6w	9.15	0.59	0.46	0.2w 16.0c	0.9 calcium (Ca) as poultry manure 1.7 calcium (Ca) as super 2.1 sulphur (S) as sulphates 0.08 aldrin	87.0	13.0	General Fertilisers Ltd.	



MIXED FERTILIZERS—continued

Grade Formula	Name of Preparation	Guaranteed Analysis											Queensland Primary Dealer
		Percentage Nitrogen (N) as			Percentage Phosphorus (P) as			Percentage Potassium (K)	Percentage Miscellaneous	Percentage Fine	Percentage Coarse		
		Nitrate Form	Ammonium Form	Other Forms	Water Sol. Form	Citrate Sol. Form	Insoluble Forms						
9-0—10-3—16-3	G.F. Hi-Blend 9-10-16 Organic	..	8-4	0-6w	9-21	0-61	0-48	0-2w 16-1c	0-9 calcium (Ca) as poultry manure 1-9 calcium (Ca) as super 2-1 sulphur (S) as sulphates	87-0	13-0	General Fertilisers Ltd.	
9-0—11-2—16-2	G.F. Hi-Blend 9-11-16	..	9-0	..	10-33	0-55	0-32	16-2c	3-0 calcium (Ca) as super 3-0 sulphur (S) as sulphates	..	..	ditto	
9-0—11-2—16-2	G.F. Hi-Blend 9-11-16 Aldrin 0-08%	..	9-0	..	10-35	0-54	0-31	16-2c	3-0 calcium (Ca) as super 3-0 sulphur (S) as sulphates 0-08 aldrin	..	..	ditto	
9-5—2-9—8-0	ACF—Austral Sweetpine (S) Cu Zn	..	9-5	..	2-1	0-3	0-5	8-0p	17-1 sulphur (S) as sulphates 6-0 calcium (Ca) as super 0-6 copper (Cu) as copper sulphate 0-5 zinc (Zn) as zinc sulphate	..	..	Consolidated Fertilizer Sales Pty. Ltd.	
10-0—1-6—16-6	G.F. 10 Gran n	..	10-0	..	1-3	0-2	0-1	16-6c	3-5 calcium (Ca) as super 13-2 sulphur (S) as sulphates	..	..	General Fertilisers Ltd.	
10-0—1-6—16-7	G.F. 10 Gran	..	10-0	..	1-16	0-33	0-11	16-7c	3-3 calcium (Ca) as super 13-2 sulphur (S) as sulphates	..	..	ditto	
10-0—2-8—8-1	G.F. Sulphapine	..	10-0	..	2-06	0-59	0-2	8-1p	5-9 calcium (Ca) as super 17-9 sulphur (S) as sulphates	..	..	ditto	
10-0—2-9—9-0	ACF—Austral Sweetpine (S)	..	10-0	..	2-1	0-3	0-5	9-0p	6-0 calcium (Ca) as super 18-0 sulphur (S) as sulphates	..	..	ditto	
10-0—3-0—10-0	Hortico Complete Garden Food	..	10-0a	..	2-47s	0-32s	0-26s	10-0c	6-5 calcium (Ca) as super 14-6 sulphur (S) as sulphates	..	..	Hortico (Qld.) Pty. Ltd.	
10-0—3-2—6-1	G.F. Top Crop 19	..	8-07	1-15w 0-78b	0-1	0-55	2-55	0-4w 5-7c	1-9 calcium (Ca) as poultry manure 2-0 calcium (Ca) as bone 9-2 sulphur (S) as sulphates	30-0	70-0	General Fertilisers Ltd.	
10-0—3-5—6-5	Lane's Lawn Fertilizer	..	10-0a	..	2-9s	0-3s	0-3s	6-5c	7-5 calcium (Ca) as super 13-5 sulphur (S) as ammonium sulphate	..	..	Lane Ltd.	

## MIXED FERTILIZERS—continued

Grade Formula	Name of Preparation	Guaranteed Analysis											Queensland Primary Dealer
		Percentage Nitrogen (N) as			Percentage Phosphorus (P) as			Percentage Potassium (K)	Percentage Miscellaneous	Percentage Fine	Percentage Coarse		
		Nitrate Form	Ammonium Form	Other Forms	Water Sol. Form	Citrate Sol. Form	Insoluble Forms						
10-0-3-9-6-1	ACF-Austral Q11 ..	..	10-0	..	2-8	0-4	0-7	6-1c	7-9 calcium (Ca) as super 15-3 sulphur (S) as sulphates	..	..	Consolidated Fertilizer Sales Pty. Ltd.	
10-0-4-0-6-2	Garden King Azalea and Camellia Fertilizer	..	10-0	..	2-1	1-0	0-9	6-2c	7-5 calcium (Ca) as super 15-1 sulphur (S) as sulphates	..	..	ditto	
10-0-4-0-6-2	Garden King Shrub and Fruit Tree Fertilizer	..	10-0	..	2-1	1-0	0-9	6-2c	7-5 calcium (Ca) as super 15-1 sulphur (S) as sulphates	..	..	ditto	
10-0-4-0-6-2	Garden King Tropic ..	..	10-0	..	2-1	1-0	0-9	6-2c	7-5 calcium (Ca) as super 15-1 sulphur (S) as sulphates	..	..	ditto	
10-0-4-4-16-6	G.F. Potato 10 ..	..	..	10-0u	3-17	0-51	0-72	16-6c	8-9 calcium (Ca) as super 4-4 sulphur (S) as sulphates	..	..	General Fertilisers Ltd.	
10-0-5-0-28-5	Crop King Tobacco 10	5-2	4-8	..	4-7	0-1	0-2	13-8p 14-7x	6-3 sulphur (S) as sulphates	..	..	Consolidated Fertilizer Sales Pty. Ltd.	
10-1-1-6-16-7	ACF-Austral Q7 ..	..	10-1	..	1-1	0-3	0-2	16-7 c	3-3 calcium (Ca) as super 13-2 sulphur (S) as sulphates	..	..	ditto	
10-1-2-3-8-1	G.F. Sulphapine Cu and Zn	..	10-1	..	1-71	0-4	0-17	8-1p	4-9 calcium (Ca) as super 16-9 sulphur (S) as sulphates 0-6 copper (Cu) as copper sulphate 0-5 zinc (Zn) as zinc sulphate	..	..	General Fertilisers Ltd.	
10-4-3-4-6-5	G.F. 9 Gran ..	..	10-4	..	2-46	0-71	0-23	6-5c	7-0 calcium (Ca) as super 15-4 sulphur (S) as sulphates	..	..	ditto	
11-0-2-5-9-3	G.F. Orchard Special Gran	..	11-0	..	1-8	0-52	0-18	9-3c	15-3 sulphur (S) as sulphates 5-2 calcium (Ca) as super	..	..	General Fertilisers Ltd.	
11-9-12-5-17-7	Crop King 66 ..	..	11-9	..	11-9	0-3	0-3	17-7c	1-9 sulphur (S) as sulphates	..	..	Consolidated Fertilizer Sales Pty. Ltd.	
11-9-12-5-17-7	Crop King 66 (A.08) ..	..	11-9	..	11-9	0-3	0-3	17-7c	1-9 sulphur (S) as sulphates 0-08 aldrin	..	..	ditto	
11-9-14-0-9-8	Crop King 55 ..	..	11-9	..	13-0	0-6	0-4	9-8c	3-1 calcium (Ca) as super 3-4 sulphur (S) as sulphates	..	..	ditto	
11-9-14-0-9-8	G.F. Hi-Blend 12-14-10 (n)	..	11-9	..	13-0	0-6	0-4	9-8c	3-1 calcium (Ca) as super 3-4 sulphur (S) as sulphates	..	..	General Fertilisers Ltd.	



## MIXED FERTILIZERS—continued

Grade Formula	Name of Preparation	Guaranteed Analysis											Queensland Primary Dealer
		Percentage Nitrogen (N) as			Percentage Phosphorus (P) as			Percentage Potassium (K)	Percentage Miscellaneous	Percentage Fine	Percentage Coarse		
		Nitrate Form	Ammonium Form	Other Forms	Water Sol. Form	Citrate Sol. Form	Insoluble Forms						
12-0-4-0-19-4	Crop King 11 .. ..	..	12-0	..	3-8	0-1	0-1	19-4c	10-0 sulphur (S) as sulphates	..	..	Consolidated Fertilizer Sales Pty. Ltd.	
12-0-4-0-19-4	Crop King 11-2 .. ..	..	1-1	10-9u	3-2	0-6	0-2	19-4c	5-9 calcium (Ca) as super sulphur (S) as sulphates	..	..	ditto	
12-0-5-2-15-7	Lane Blue Chip .. ..	5-4	6-6	..	2-0	3-2	..	15-7p	0-3 maximum biuret sulphates	..	..	Lane Ltd.	
12-0-5-2-15-7	Lane's Blue Chip .. ..	5-4	6-6	..	2-0	3-2	..	15-7p	3-2 calcium (Ca) as calcium phosphate sulphates	..	..	ditto	
12-0-12-3-18-1	Crop King 66-1 .. ..	..	12-0	..	11-7	0-3	0-3	18-1c	5-2 sulphur (S) as sulphates	..	..	Consolidated Fertilizer Sales Pty. Ltd.	
12-1-4-1-17-2	G.F. Hi-Blend 12-4-17 Aldrin 0-06%	..	12-1	..	3-9	0-1	0-1	17-2c	1-8 sulphur (S) as sulphates	..	..	General Fertilisers Ltd.	
12-1-14-0-10-0	G.F. Hi-Blend 12-14-10 Aldrin 12%	..	12-1	..	13-02	0-58	0-4	10-0c	0-7 calcium (Ca) as super sulphur (S) as sulphates	..	..	ditto	
12-1-14-1-10-3	G.F. Hi-Blend 12-14-10	..	12-1	..	13-1	0-6	0-4	10-3c	10-6 sulphur (S) as sulphates	..	..	ditto	
12-2-4-1-17-2	G.F. Hi-Blend 12-4-17	..	12-2	..	3-9	0-1	0-1	17-2c	0-06 aldrin super sulphur (S) as sulphates	..	..	ditto	
12-2-13-1-10-1	G.F. Hi-Blend 12-13-10 Organic	..	11-6	0-6w	12-0	0-63	0-47	0-2w 9-9c	0-12 aldrin super sulphur (S) as sulphates	..	..	ditto	
12-3-2-0-13-3	Crop King 77 (S) Cu Zn	..	12-3	..	1-9	..	0-1	13-3p	2-8 calcium (Ca) as super sulphur (S) as sulphates	..	..	Consolidated Fertilizer Sales Pty. Ltd.	
12-3-2-0-13-3	Crop King 77 (S) Cu Zn-2	..	5-6	6-7u	1-9	..	0-1	13-3p	3-3 sulphur (S) as sulphates	..	..	ditto	

## MIXED FERTILIZERS—continued

Grade Formula	Name of Preparation	Guaranteed Analysis										Queensland Primary Dealer
		Percentage Nitrogen (N) as			Percentage Phosphorus (P) as			Percentage Potassium (K)	Percentage Miscellaneous	Percentage Fine	Percentage Coarse	
		Nitrate Form	Ammonium Form	Other Forms	Water Sol. Form	Citrate Sol. Form	Insoluble Forms					
12-3-13-0-10-1	G.F. Hi-Blend 12-13-10 Organic Aldrin 12%	..	11.7	0.6w	11.94	0.61	0.45	0.2w 9.9c	0.9 calcium (Ca) as poultry manure 0.7 calcium (Ca) as super 2.1 sulphur (S) as sulphates 0.12 aldrin	87.0	13.0	General Fertilisers Ltd.
12-4-5-2-15-1	G.F. Hi-Blend 12-5-15 (S)	..	12.4	..	4.94	0.13	0.13	15.1p	15.5 sulphur (S) as sulphates	..	..	ditto
13-0-14-3-10-1	G.F. Hi-Blend 13-14-10 (S)	..	13.0	..	13.5	0.43	0.37	10.1p	1.0 calcium (Ca) as super 11.0 sulphur (S) as sulphates	..	..	ditto
13-2-2.1-14.4	Crop King 77 (S)-1	..	13.2	..	2.0	..	0.1	14.4p	18.8 sulphur (S) as sulphates	..	..	Consolidated Fertilizer Sales Pty. Ltd.
13-2-2.2-14.3	Crop King 77 (S)	..	13.2	..	2.1	..	0.1	14.3p	18.8 sulphur (S) as sulphates	..	..	ditto
13-2-2.2-14.3	Crop King 77 (S)-2	..	6.1	7.1u	1.8	0.3	0.1	14.3p	1.2 calcium (Ca) as super 14.2 sulphur (S) as sulphates	..	..	ditto
13.5-1.7-14.2	G.F. Hi-Blend Sulphapine No. 2	..	5.7	7.8u	1.23	0.36	0.11	14.2p	0.2 maximum biuret 3.5 calcium (Ca) as super 14.0 sulphur (S) as sulphates	..	..	General Fertilisers Ltd.
14.0-6.1-11.6	Osmocote 14-6.1-11.6	5.6	8.4	..	4.9	1.2	..	11.6p	4.8 sulphur (S) as potassium sulphate	..	..	Burnell Agencies
14.4-4.8-9.8	G.F. Potato 9	..	..	14.4u	3.46	0.56	0.78	9.8c	9.7 calcium (Ca) as super 4.8 sulphur (S) as sulphates	..	..	General Fertilisers Ltd.
14.7-0-33.0	Crop King Banana 130	..	..	14.7u	..	..	..	33.0c	..	..	..	Consolidated Fertilizer Sales Pty. Ltd.
15.3-4.3-11.7	Crop King 88	..	15.3	..	4.1	0.1	0.1	11.7c	13.4 sulphur (S) as sulphates	..	..	ditto
15.3-4.3-11.7	Crop King 88-2	..	4.0	11.3u	3.2	0.8	0.3	11.7c	5.3 calcium (Ca) as super 6.4 sulphur (S) as sulphates	..	..	ditto
15.4-3.0-10.3	G.F. Hi-Blend 15-3-10	..	15.4	..	2.82	0.08	0.1	10.3c	0.3 maximum biuret 0.4 calcium (Ca) as super 15.3 sulphur (S) as sulphates	..	..	General Fertilisers Ltd.
16.0-3.0-10.0	Agriform 16-3-10 (+iron)	8.0	8.0	..	2.4	0.6	..	6.7p 3.3x	3.0 sulphur (S) as potassium sulphate 3.0 sulphur (S) as iron sulphides and sulphates 2.0 iron (Fe) as iron sulphides and sulphates	..	..	Burnell Agencies



MIXED FERTILIZERS—continued

Grade Formula	Name of Preparation	Guaranteed Analysis											Queensland Primary Dealer
		Percentage Nitrogen (N) as			Percentage Phosphorus (P) as			Percentage Potassium (K)	Percentage Miscellaneous	Percentage Fine	Percentage Coarse		
		Nitrate Form	Ammonium Form	Other Forms	Water Sol. Form	Citrate Sol. Form	Insoluble Forms						
16.2-4.1-11.2	G.F. Potato 15 .. ..	..	..	16.2u	2.95	0.48	0.67	11.2c	8.3 calcium (Ca) as super sulphates	..	..	General Fertilisers Ltd.	
17.6-0-8.0	Hortico Soluble Lawn Food	..	17.6a	..	..	..	..	8.0c	4.1 sulphur (S) as ammonium sulphate	..	..	Hortico (Qld.) Pty. Ltd.	
18.0-2.6-10.0	Osmocote 18-2.6-10 ..	8.4	9.6	..	2.0	0.6	..	10.0p	4.1 sulphur (S) as potassium sulphate	..	..	Burnell Agencies	
19.0-2.6-10.0	Osmocote 19-2.6-10 ..	9.0	10.0	..	2.0	0.6	..	10.0p	4.4 sulphur (S) as potassium sulphate	..	..	Burnell Agencies	
19.0-2.6-10.8	Agriform CRF 19-2.6-10.8	9.0	10.0	..	2.0	0.6	..	10.8p	4.4 sulphur (S) as potassium sulphate	..	..	ditto	
19.0-6.1-19.0	G.F. Hi-Blend 19-6-19	..	5.8	13.2u	5.9	0.1	0.1	19.0c	0.9 sulphur (S) as sulphates	..	..	General Fertilisers Ltd.	
19.5-5.3-20.0	A.C.N. "Super-Gro" Soluble Fertiliser	..	4.8e	14.7u	5.1	0.1	0.1	20.0c	..	..	..	Acacia Nurseries	
19.8-8.6-0	Crop King 500 .. ..	..	19.8	..	8.2	0.2	0.2	..	15.4 sulphur (S) as sulphates	..	..	Consolidated Fertilizer Sales Pty. Ltd.	
20.2-5.1-0	G.F. Hi-Blend 20-5-0 ..	..	..	20.2u	3.7	1.06	0.34	..	5.3 sulphur (S) as sulphates	..	..	General Fertilisers Ltd.	
20.3-5.2-0	Crop King 600 .. ..	..	..	20.3u	3.7	1.1	0.4	..	10.7 calcium (Ca) as super sulphates	..	..	Consolidated Fertilizer Sales Pty. Ltd.	
20.5-5.0-19.4	Crop King 110 .. ..	..	4.8	15.7u	4.7	0.1	0.2	19.4c	5.4 sulphur (S) as sulphates	..	..	ditto	
22.0-2.0-22.0	G.F. Hi-Blend 22-2-22	..	1.97	20.3u	1.9	0.05	0.05	22.0c	10.8 calcium (Ca) as super sulphates	..	..	ditto	
24.1-4.3-16.0	G.F. Hi-Blend 24-4-16	..	4.2	19.9u	4.1	0.1	0.1	16.0c	0.7 sulphur (S) as sulphates	..	..	General Fertilisers Ltd.	
24.3-2.5-18.4	G.F. Hi-Blend 24-2-18	..	2.4	21.9u	2.4	0.05	0.05	18.4c	0.3 sulphur (S) as sulphates	..	..	ditto	
24.6-2.5-18.6	Crop King 140 .. ..	..	2.3	22.3u	2.3	0.1	0.1	18.6c	0.6 sulphur (S) as sulphates	..	..	Consolidated Fertilizer Sales Pty. Ltd.	
24.6-2.5-18.6	G.F. Hi-Blend 24-2-18 (n)	..	2.3	22.3u	2.3	0.1	0.1	18.6c	0.4 sulphur (S) as sulphates	..	..	General Fertilisers Ltd.	
25.3-5.0-14.1	Crop King 120 .. ..	..	4.8	20.5u	4.8	0.1	0.1	14.1c	0.4 sulphur (S) as sulphates	..	..	Consolidated Fertilizer Sales Pty. Ltd.	
31.5-0-12.3	ACF-Austral 31.5-0-12.3	..	..	31.5u	..	..	..	12.3p	0.8 sulphur (S) as sulphates	..	..	ditto	
31.6-10.0-0	G.F. Hi-Blend 31-10-0	..	9.47	22.13u	9.5	0.25	0.25	..	4.9 sulphur (S) as sulphates	..	..	General Fertilisers Ltd.	
32.0-0-12.4	Garden King Supergreen Soluble Lawn Food	..	..	32.0u	..	..	..	12.4p	1.4 sulphur (S) as sulphates	..	..	General Fertilisers Ltd.	
32.5-9.3-0	Crop King 700 .. ..	..	8.8	23.7u	8.8	0.2	0.3	..	5.0 sulphur (S) as potassium sulphate	..	..	Consolidated Fertilizer Sales Pty. Ltd.	
33.2-2.0-10.0	ACF-Austral 32-2-10 ..	..	2.0	31.2u	1.9	0.1	..	10.0c	1.4 sulphur (S) as sulphates	..	..	ditto	
33.6-2.0-10.5	Barmac Nor-mul Fertiliser for Tidwarf Greens	3.75x	1.85e	28.0u	2.0e	..	..	10.5x	0.3 sulphur (S) as sulphates	..	..	ditto	
34.0-1.7-11.6	Barmac Greenkeeper Super-Gro Soluble Fertiliser	4.1x	1.5e	28.4u	1.7e	..	..	11.6x	1.5 maximum biuret	..	..	Barnes McGrath Pty. Ltd.	
									0.2 maximum biuret	..	..	ditto	

## MISCELLANEOUS FERTILIZERS

## GUARANTEED ANALYSIS

Name of Preparation	Percentage Nitrogen (N)	Percentage Phosphorus (P)	Percentage Potassium (K)	Percentage Miscellaneous	Queensland Primary Dealer
Atlas Fish Emulsion	5.0 as fish organic form	0.5 as fish organic form	0.8 as fish organic form	..	Acacia Nurseries
Maxicrop Seaweed Plant Food	0.053 as organic form from seaweed	0.063 as organic form from seaweed	0.18 as organic form from seaweed	..	Acacia Nurseries
Barmac Greenfinger Gar.Den.Gro	19.0 as urea 5.0 as diammonium phosphate	5.3 as diammonium phosphate	12.0 as potassium sulphate	0.9 maximum biuret 0.3 magnesium (Mg) as magnesium sulphate 0.2 iron (Fe) as ferrous sulphate 0.16 manganese (Mn) as manganese sulphate 0.085 copper (Cu) as cupric sulphate 0.013 zinc (Zn) as zinc sulphate 0.025 molybdenum (Mo) as sodium molybdate 0.003 boron (B) as sodium borate 5.0 sulphur (S) as sulphates	Barnes McGrath Pty. Ltd.
Barmac Greenkeeper Auto-Fert A	2.7 as diammonium phosphate 11.5 as urea	3.0 as diammonium phosphate	5.0 as potassium chloride	0.6 maximum biuret 0.09 iron (Fe) as polyflavonoids 0.05 zinc (Zn) as polyflavonoids 0.02 manganese (Mn) as polyflavonoids 0.006 copper (Cu) as polyflavonoids 0.12 sulphur (S) as polyflavonoids 0.15 thiamine hydrochloride 0.005 indol-3-yl acetic acid 0.005 B-naphthoxy acetic acid 50.0 water	Barnes McGrath Pty. Ltd.



MISCELLANEOUS FERTILIZERS—continued

GUARANTEED ANALYSIS

Name of Preparation	Percentage Nitrogen (N)	Percentage Phosphorus (P)	Percentage Potassium (K)	Percentage Miscellaneous	Queensland Primary Dealer
Barmac Greenkeeper Auto-Fert B	3.6 as diammonium phosphate 10.5 as urea	4.1 as diammonium phosphate	5.0 as potassium chloride	0.5 maximum biuret 0.09 iron (Fe) as polyflavonoids 0.05 zinc (Zn) as polyflavonoids 0.02 manganese (Mn) as polyflavonoids 0.006 copper (Cu) as polyflavonoids 0.12 sulphur (S) as polyflavonoids 54.0 water	Barnes McGrath Pty. Ltd.
Barmac Greenkeeper Auto-Fert C	2.7 as diammonium phosphate 11.5 as urea	3.0 as diammonium phosphate	5.0 as potassium chloride	0.5 maximum biuret 0.09 iron (Fe) as polyflavonoids 0.05 zinc (Zn) as polyflavonoids 0.02 manganese (Mn) as polyflavonoids 0.006 copper (Cu) as polyflavonoids 0.12 sulphur (S) as polyflavonoids 54.0 water	ditto
Barmac Greenkeeper Bal-A-Fert	0.24 as potassium nitrate	4.27 as potassium dihydrogen phosphate	0.69 as potassium nitrate 5.4 as potassium dihydrogen phosphate	0.39 magnesium (Mg) as magnesium sulphate 0.5 sulphur (S) as magnesium sulphate 0.03 iron (Fe) as iron polyflavonoids 0.02 zinc (Zn) as zinc polyflavonoids 75.0 water	ditto
Barmac Greenkeeper Bracer for Bowling and Golf Greens	6.5 as potassium nitrate	5.6 water sol. as potassium dihydrogen phosphate	19.0 as potassium nitrate 7.0 as potassium dihydrogen phosphate	2.4 magnesium (Mg) as magnesium sulphate	ditto

## MISCELLANEOUS FERTILIZERS—continued

GUARANTEED ANALYSIS					
Name of Preparation	Percentage Nitrogen (N)	Percentage Phosphorus (P)	Percentage Potassium (K)	Percentage Miscellaneous	Queensland Primary Dealer
Barmac Greenkeeper Hybrent	2.46 as monoammonium phosphate 0.83 as potassium nitrate 4.1 as ammonium sulphate 12.88 as urea	5.42 water sol. as monoammonium phosphate	2.33 as potassium nitrate 8.8 as potassium sulphate	9.0 sulphur (S) as sulphates 0.06 copper (Cu) as copper sulphate 0.055 zinc (Zn) as zinc sulphate 0.1 molybdenum (Mo) as sodium molybdate 0.11 manganese (Mn) as manganese sulphate 0.007 boron (B) as sodium borate 0.1 iron (Fe) as ferrous lignin	Barnes McGrath Pty. Ltd.
Barmac Greenkeeper Special Soluble Fertiliser	19.78 as urea 6.12 as ammonium sulphate 1.0 as diammonium phosphate	1.25 water sol. as diammonium phosphate	8.0 as potassium sulphate	0.1 iron (Fe) as ferrous sulphate 0.1 molybdenum (Mo) as sodium molybdate 0.11 manganese (Mn) as manganese sulphate 0.06 copper (Cu) as cupric sulphate 0.055 zinc (Zn) as zinc sulphate 0.007 boron (B) as sodium borate 10.0 sulphur (S) as sulphates 0.5 tetramethyl-di-p-aminotriphenylcarbonol chloride 0.9 maximum biuret	ditto
Barmac Greenkeeper Summermix Soluble Fertiliser	11.96 as urea 2.8 as ammonium sulphate 1.9 as monoammonium phosphate 5.5 as potassium nitrate	4.23 water sol. as monoammonium phosphate	15.5 as potassium nitrate	0.6 maximum biuret 3.0 sulphur (S) as sulphates 0.08 manganese (Mn) as maneb 0.09 zinc (Zn) as zineb 0.4 molybdenum (Mo) as sodium molybdate 0.19 magnesium (Mg) as magnesium sulphate 0.25 copper (Cu) as copper oxychloride	ditto
Barmac Greenkeeper Wintermix	11.9 as urea 2.3 as diammonium phosphate 7.3 as potassium nitrate	2.5 water sol. as diammonium phosphate	23.0 as potassium nitrate	0.6 maximum biuret 0.13 iron (Fe) as ferrous lignin	ditto



MISCELLANEOUS FERTILIZERS—continued

GUARANTEED ANALYSIS

Name of Preparation	Percentage Nitrogen (N)	Percentage Phosphorus (P)	Percentage Potassium (K)	Percentage Miscellaneous	Queensland Primary Dealer
Barmac Nitrosol Dispersible Liquid Plant Food	7.5 as blood, bone and offal	0.43 as bone 2.4 as monocalcium phosphate	0.83 as potassium chloride	0.86 calcium (Ca) as bone 1.5 calcium (Ca) as monocalcium phosphate 30.0 water	Barnes McGrath Pty. Ltd.
Barmac Turf Renovation Mixture	1.6 as vegetable meal 5.6 as ammonium sulphate	2.68 as sterilised bone flour	6.8 as potassium sulphate	9.0 sulphur (S) as sulphates 3.4 calcium (Ca) as bone 6.0 quintozene	ditto
Foliar Nitrophoska	1.2—nitrate form 0.4—ammonium form 8.5 as urea	1.75 water soluble	5.9 as potassium sulphate, potassium nitrate and monopotassium phosphate	0.3 magnesium (Mg) as magnesium sulphate 0.0025 copper (Cu) as copper sulphate 0.0022 boron (B) as boric acid 0.002 manganese (Mn) as manganese sulphate 0.0005 zinc (Zn) as zinc sulphate 0.0003 cobalt (Co) as Cobalt sulphate 0.0003 molybdenum (Mo) as ammonium molybdate	BASF Australia Ltd.
Bayer Bayfolan Liquid Leaf Fertilizer	5.0—nitrate form 6.0—ammonium form	3.5—water sol. as diammonium phosphate	0.7 as potassium sulphate 3.5 as potassium nitrate 0.7 as potassium chloride	0.0185 iron (Fe) as iron sulphate 0.008 copper (Cu) as copper sulphate 0.0004 cobalt (Co) as cobalt sulphate 0.016 manganese (Mn) as manganese sulphate 0.006 zinc (Zn) as zinc sulphate 0.00095 molybdenum (Mo) as sodium molybdate 0.0113 boron (B) as borax 56.0 water	Bayer Australia Ltd.
Agriform Forest Starter Tablets 18—3.5—2.5	18.0 as urea formaldehyde	3.5 citrate sol. as calcium phosphate	2.5 as fritted potash	3.0 calcium (Ca) as calcium phosphates and calcium sulphate 0.5 magnesium (Mg) as magnesium sulphate 1.5 sulphur (S) as sulphates 0.5 iron (Fe) as ferrous sulphate 0.1 zinc (Zn) as zinc sulphate 0.54 maximum biuret	Burnell Agencies

## MISCELLANEOUS FERTILIZERS—continued

GUARANTEED ANALYSIS					
Name of Preparation	Percentage Nitrogen (N)	Percentage Phosphorus (P)	Percentage Potassium (K)	Percentage Miscellaneous	Queensland Primary Dealer
Agriform Grape Starter Tablets 28—3.5—3.3	3.0 as diammonium phosphate 25.0 as urea formaldehyde	3.5 water sol. as diammonium phosphate	3.3 as potassium sulphate	0.2 calcium (Ca) as calcium sulphate 2.0 sulphur (S) as sulphates 1.0 iron (Fe) as ferrous sulphate 0.2 zinc (Zn) as zinc sulphate 0.75 maximum biuret	Burnell Agencies
Agriform Orchard Starter Tablets 28—3.5—3.3	3.0 as diammonium phosphate 25.0 as urea formaldehyde	3.5 water sol. as diammonium phosphate	3.3 as potassium sulphate	0.2 calcium (Ca) as calcium sulphate 2.0 sulphur (S) as sulphates 1.0 iron (Fe) as ferrous sulphate 0.2 zinc (Zn) as zinc sulphate 0.75 maximum biuret	ditto
Agriform Planting Tablets 20—4.3—4.1	20.0 as urea formaldehyde	4.3 citrate sol. as calcium phosphates	4.1 as potassium sulphate	2.6 calcium (Ca) as calcium phosphates and calcium sulphate 1.6 sulphur (S) as sulphates 0.35 iron (Fe) as ferrous sulphate 0.6 maximum biuret	ditto
Fogg-It Fish Emulsion Fertilizer	0.5 as ammonium form 4.5 as fish organic form	1.0 as fish organic form	1.6 as fish organic form		ditto
Campbell Trifol Foliar Nutrient	5.03 as nitrate form 4.14 as ammonium form 13.07 as urea	9.16—water soluble	14.07 as potassium nitrate	0.0136 zinc (Zn) as zinc sulphate 0.01525 copper (Cu) as copper sulphate 0.01 molybdenum (Mo) as sodium molybdate 0.004 cobalt (Co) as cobalt sulphate 0.0395 manganese (Mn) as manganese sulphate 0.037 iron (Fe) as iron sulphate 0.0066 boron (B) as boric acid 0.079 magnesium (Mg) as magnesium sulphate	Colin Campbell (Chemicals) Pty. Ltd.



MISCELLANEOUS FERTILIZERS—continued

GUARANTEED ANALYSIS

Name of Preparation	Percentage Nitrogen (N)	Percentage Phosphorus (P)	Percentage Potassium (K)	Percentage Miscellaneous	Queensland Primary Dealer
Turf-King Liquid Fertilizer	15.8 as urea 2.2 as diammonium phosphate	1.3 as potassium phosphate 2.3 as diammonium phosphate 1.2 as phosphoric acid	5.1 as potassium phosphate	0.012 copper (Cu) as copper sulphate 0.01 cobalt (Co) as cobalt sulphate 0.01 zinc (Zn) as zinc sulphate 0.015 manganese (Mn) as manganese sulphate 0.025 molybdenum (Mo) as molybdic acid 0.015 boron (B) as boric acid 0.06 iron (Fe) as ferrous sulphate 0.035 magnesium (Mg) as magnesium sulphate 56.9 water	Chemsearch Australia Pty. Ltd.
Crop King Fertica	5.0—nitrate form 6.5—ammonium form	4.1—water soluble 0.5 citrate soluble 0.3—insoluble	14.0 as potassium nitrate	7.5 sulphur (S) as sulphates 4.8 calcium (Ca) as super 1.3 magnesium (Mg) as magnesium oxide 0.1 boron (B) as borax 0.1 manganese (Mn) as manganese sulphate 0.04 copper (Cu) as copper oxide 0.02 zinc (Zn) as zinc oxide 0.0006 cobalt (Co) as cobalt sulphate	Consolidated Fertilizer Sales Pty. Ltd.
Garden King Liquifert	16.75 as urea 8.25 as diammonium phosphate	9.1—water sol. as diammonium phosphate	9.5 as potassium chloride	0.1 copper (Cu) as copper sulphate 0.012 molybdenum (Mo) as sodium molybdate 0.045 magnesium (Mg) as magnesium sulphate 0.15 manganese (Mn) as manganese sulphate 0.05 boron (B) as sodium borate	Consolidated Fertilizer Sales Pty. Ltd.

## MISCELLANEOUS FERTILIZERS—continued

GUARANTEED ANALYSIS					
Name of Preparation	Percentage Nitrogen (N)	Percentage Phosphorus (P)	Percentage Potassium (K)	Percentage Miscellaneous	Queensland Primary Dealer
Pikes Rite Gro Slow Release Plant Pills	10.0 as urea formaldehyde	1.35—water sol. 0.25—citrate sol. 0.5—insoluble	5.0 as potassium sulphate	1.6 calcium (Ca) as calcium carbonate 1.1 calcium (Ca) as calcium sulphate 3.3 calcium (Ca) as super 2.5 sulphur (S) as sulphates 0.2 iron (Fe) as ferrous sulphate 6.0 organic peat 10.0 silica 10.5 talcum	Consolidated Fertilizer Sales Pty. Ltd.
“Liquiphos” 0—7—14	..	7.0—water sol. as potassium phosphates	14.0 as potassium phosphates	54.0 water 0.5 sodium alginate	Galdonost Dynamics (N.Z.) Ltd.
“Liquiphos” 8—5—10	8.0 as urea	5.0—water sol. as potassium phosphates	10.0 as potassium phosphates	50.0 water 0.5 sodium alginate	ditto
“Liquiphos” 10—3—6	10.0 as urea	3.0—water sol. as potassium phosphates	6.0 as potassium phosphates	58.0 water 0.5 sodium alginate	ditto
“Liquiphos” 16—2—4	16.0 as urea	2.0—water sol. as potassium phosphates	4.0 as potassium phosphates	61.0 water 0.5 sodium alginate	ditto
“Liquiphos” 20% N	20.0 as urea	..	..	53.0 water 0.5 sodium alginate	ditto
+S Sulphur Additive	..	..	..	15.0 sulphur (S) as anhydrous sodium thiosulphate 62.0 water 0.6 sodium alginate	ditto



MISCELLANEOUS FERTILIZERS—continued

GUARANTEED ANALYSIS

Name of Preparation	Percentage Nitrogen (N)	Percentage Phosphorus (P)	Percentage Potassium (K)	Percentage Miscellaneous	Queensland Primary Dealer
G.F. King Leaf Tobacco 315+ Trace Elements	2.4—nitrate form	3.8—water sol. 0.6—citrate sol. 0.8—insoluble	7.3 as potassium nitrate 7.7 as potassium sulphate	10.0 calcium (Ca) as super 8.0 sulphur (S) as sulphates 2.5 magnesium (Mg) as magnesium oxide 0.2 copper (Cu) as copper sulphate 0.2 zinc (Zn) as zinc sulphate 0.15 manganese (Mn) as manganese sulphate 0.04 boron (B) as sodium borate 0.02 molybdenum (Mo) as sodium molybdate	General Fertilisers Ltd.
Leffingwell Sorba Spray ZKP	..	5.0—water sol. as phosphoric acid 1.9 water sol. as potassium phosphate	7.5 as potassium phosphate	1.0 zinc (Zn) as zinc sulphate 0.3 sulphur (S) as sulphates	ditto
Hoechst Complesal Fluid Red Foliar Fertilizer	4.9 as urea 1.0 as potassium nitrate	4.2—water soluble	3.0 as potassium nitrate 7.1 as potassium phosphate	0.145 magnesium (Mg) } As 0.012 copper (Cu) } organic 0.012 iron (Fe) } complexes 0.012 manganese (Mn) } of phosphoric acid 0.006 zinc (Zn) 0.024 boron (B) as potassium borate 0.006 molybdenum (Mo) as ammonium molybdate	Hoechst Australia Ltd.
Hoechst Complesal Supra Blue Special Complete Fertilizer	5.5—nitrate form 6.5—ammonium form	2.0—water soluble 3.2—citrate soluble	7.5 as potassium chloride 6.6 as potassium sulphate	1.2 magnesium (Mg) as magnesium carbonate 6.9 calcium (Ca) as dicalcium phosphate 2.8 sulphur (S) as sulphates	ditto
Poliverdol foliar fertilizer	3.7—nitrate form 5.3—ammonium form	3.9—water soluble	0.8 as potassium sulphate 4.1 as potassium nitrate 0.8 as potassium chloride	0.0185 iron (Fe) as iron sulphate 0.006 zinc (Zn) as zinc sulphate 0.016 manganese (Mn) as manganese sulphate 0.0113 boron (B) as borax 0.0004 cobalt (Co) as cobalt sulphate	ditto

continued next page

## MISCELLANEOUS FERTILIZERS—continued

## GUARANTEED ANALYSIS

Name of Preparation	Percentage Nitrogen (N)	Percentage Phosphorus (P)	Percentage Potassium (K)	Percentage Miscellaneous	Queensland Primary Dealer
Poliverdol foliar fertilizer— <i>continued</i>				0.008 copper (Cu) as copper sulphate 0.00095 molybdenum (Mo) as sodium molybdate 54.5 water	Hoechst Australia Ltd.
Aquasol	1.8 as monoammonium phosphate 2.6 as potassium nitrate 18.6 as urea	4.0 water sol. as monoammonium phosphate	7.8 as potassium nitrate 10.2 as potassium chloride	0.05 zinc (Zn) as zinc sulphate 0.06 copper (Cu) as copper sulphate 0.0013 molybdenum (Mo) as sodium molybdate 0.04 sulphur (S) as sulphates 0.15 manganese (Mn) as manganese sulphate 0.06 iron (Fe) as sodium ferric EDTA 0.011 boron (B) as sodium borate 0.165 magnesium (Mg) as magnesium sulphate 0.4 maximum biuret	Hortico (Qld.) Pty. Ltd.
Aquasol Slow Release Plant Pills	12.0 as urea formaldehyde	1.67—water soluble 0.31—citrate soluble 0.62—insoluble	10.0 as potassium sulphate	0.02 zinc (Zn) as zinc sulphate 0.03 copper (Cu) as copper sulphate 0.0006 molybdenum (Mo) as sodium molybdate 0.08 manganese (Mn) as manganese sulphate 0.5 iron (Fe) as ferrous sulphate 0.006 boron (B) as borax 0.09 magnesium (Mg) as magnesium sulphate 1.6 calcium (Ca) as calcium carbonate 1.1 calcium (Ca) as calcium sulphate 4.0 calcium (Ca) as superphosphate 2.5 sulphur (S) as sulphates 3.5 sterilized organic peat	ditto



MISCELLANEOUS FERTILIZERS—continued

GUARANTEED ANALYSIS

Name of Preparation	Percentage Nitrogen (N)	Percentage Phosphorus (P)	Percentage Potassium (K)	Percentage Miscellaneous	Queensland Primary Dealer
Hortico Aquasol Houseplant Food with Seaweed Extract	0.74 as monoammonium phosphate 1.94 as potassium nitrate 4.15 as urea	1.65 as monoammonium phosphate	5.67 as potassium nitrate	3.8 seaweed extract 0.044 maximum biuret 79.0 water	Hortico (Qld.) Pty. Ltd.
Hortico Azalea Camellia and Rhodo-Daphne Food	4.0 as ammonium sulphate	4.85 water sol. as superphosphate 0.64 citrate sol. as superphosphate 0.51 insoluble as superphosphate	7.5 as potassium chloride	0.1 iron (Fe) as ferrous sulphate 0.05 magnesium (Mg) as magnesium oxide 0.06 copper (Cu) as copper sulphate 0.07 manganese (Mn) as manganese sulphate 0.007 boron (B) as borax 0.001 molybdenum (Mo) as sodium molybdate 12.7 calcium (Ca) as super 11.0 sulphur (S) as sulphates	ditto
Hortico Plant Starter	2.6 as blood and bone 0.9 as urea	1.3 citrate sol. as blood and bone 2.2 insoluble as blood and bone	5.0 as potassium chloride	0.02 zinc (Zn) as zinc sulphate 0.03 copper (Cu) as copper sulphate 0.0007 molybdenum (Mo) as sodium molybdate 0.07 manganese (Mn) as manganese sulphate 0.1 iron (Fe) as iron sulphate 0.006 boron (B) as borax 0.09 magnesium (Mg) as magnesium sulphate 0.24 sulphur (S) as sulphates 3.86 calcium (Ca) as bone 64.5 fine material 35.5 coarse material	ditto
Agrico Bent Hy-Dro-Mel (Green)	3.3 as diammonium phosphate 9.4 as urea	3.7 water soluble as diammonium phosphate	4.4 as potassium chloride	..	Lane Ltd.

## MISCELLANEOUS FERTILIZERS—continued

GUARANTEED ANALYSIS					
Name of Preparation	Percentage Nitrogen (N)	Percentage Phosphorus (P)	Percentage Potassium (K)	Percentage Miscellaneous	Queensland Primary Dealer
Agrico Foli-Fert	15.8 as urea 4.0 as diammonium phosphate 6.2 as potassium nitrate	4.4—water soluble as diammonium phosphate	17.4 as potassium nitrate	0.04 iron (Fe) as iron chelates 0.07 magnesium (Mg) as magnesium sulphate 0.01 copper (Cu) as copper sulphate 0.03 manganese (Mn) as manganese sulphate 0.003 zinc (Zn) as zinc sulphate 0.001 boron (B) as borax 0.001 molybdenum (Mo) as sodium molybdate 0.0003 cobalt (Co) as cobalt sulphate 0.7 sulphur (S) as sulphates 55 ppm vitamin B <sub>1</sub> 0.276 ppm vitamin B <sub>2</sub> 0.138 ppm vitamin B <sub>6</sub> 0.55 ppm niacin 0.138 ppm indole acetic acid 28.2 ppm l-naphthyl acetic acid	Lane Ltd.
Agrico H.D. Special Fertilizer	16.0 as urea 6.0—ammonium form	4.3—water soluble	18.2 as potassium chloride	0.0605 iron (Fe) as iron sulphate 0.0695 magnesium (Mg) as magnesium sulphate 0.0175 copper (Cu) as copper sulphate 0.034 manganese (Mn) as manganese sulphate 0.0031 zinc (Zn) as zinc sulphate 0.0014 boron (B) as borax 0.0015 molybdenum (Mo) as sodium molybdate 0.00038 cobalt (Co) as cobalt sulphate 55 ppm vitamin B <sub>1</sub> 0.276 ppm vitamin B <sub>2</sub> 0.138 ppm vitamin B <sub>6</sub> 0.55 ppm niacin 0.138 ppm indole acetic acid 28.2 ppm naphthalene acetic acid	ditto



MISCELLANEOUS FERTILIZERS—continued

GUARANTEED ANALYSIS

Name of Preparation	Percentage Nitrogen (N)	Percentage Phosphorus (P)	Percentage Potassium (K)	Percentage Miscellaneous	Queensland Primary Dealer
Lane Foli-Fert	15.8 as urea 4.0 as diammonium phosphate 6.2 as potassium nitrate	4.4 water sol. as diammonium phosphate	17.4 as potassium nitrate	0.04 iron (Fe) as iron chelates 0.07 magnesium (Mg) as magnesium sulphate 0.01 copper (Cu) as copper sulphate 0.03 manganese (Mn) as manganese sulphate 0.003 zinc (Zn) as zinc sulphate 0.001 boron (B) as borax 0.001 molybdenum (Mo) as sodium molybdate 0.0003 cobalt (Co) as cobalt sulphate 0.7 sulphur (S) as sulphates 55 ppm vitamin B <sub>1</sub> 0.276 ppm vitamin B <sub>2</sub> 0.138 ppm vitamin B <sub>6</sub> 0.55 ppm niacin 0.138 ppm indole acetic acid 28.2 ppm l-naphthyl acetic acid	Lane Ltd.
Lane Garden Gold Soluble Plant Food	15.8 as urea 4.0 as diammonium phosphate 6.2 as potassium nitrate	4.4—water soluble	17.4 as potassium nitrate	0.04 iron (Fe) as iron chelate 0.07 magnesium (Mg) as magnesium sulphate 0.01 copper (Cu) as copper sulphate 0.03 manganese (Mn) as manganese sulphate 0.003 zinc (Zn) as zinc sulphate 0.001 boron (B) as borax 0.001 molybdenum (Mo) as sodium molybdate 0.0003 cobalt (Co) as cobalt sulphate 0.7 sulphur (S) as sulphates 55 ppm vitamin B <sub>1</sub> 0.276 ppm vitamin B <sub>2</sub> 0.138 ppm vitamin B <sub>6</sub> 0.55 ppm niacin 0.138 ppm indole acetic acid 28.2 ppm naphthalene acetic acid	Lane Ltd.

## MISCELLANEOUS FERTILIZERS—continued

## GUARANTEED ANALYSIS

Name of Preparation	Percentage Nitrogen (N)	Percentage Phosphorus (P)	Percentage Potassium (K)	Percentage Miscellaneous	Queensland Primary Dealer
Lane H.D. Special Fertilizer	6.0—ammonium form 16.0 as urea	4.3—water soluble	18.2 as potassium chloride	0.0605 iron (Fe) as iron sulphate 0.0695 magnesium (Mg) as magnesium sulphate 0.0175 copper (Cu) as copper sulphate 0.034 manganese (Mn) as manganese sulphate 0.0031 zinc (Zn) as zinc sulphate 0.0014 boron (B) as borax 0.0015 molybdenum (Mo) as sodium molybdate 0.00038 cobalt (Co) as cobalt sulphate 55 ppm vitamin B <sub>1</sub> 0.276 ppm vitamin B <sub>2</sub> 0.138 ppm vitamin B <sub>6</sub> 0.55 ppm niacin 0.138 ppm indole acetic acid 28.2 ppm naphthalene acetic acid	Lane Ltd.
Flourish Slow Release Fertilizer 11.6—5.5—10.5	11.6 as ammonium form	5.0—water soluble 0.4—citrate soluble 0.1—insoluble	10.5 as potassium chloride	0.2 iron (Fe) as ferrous sulphate 0.001 molybdenum (Mo) as ammonium molybdate 0.001 cobalt (Co) as cobalt sulphate 0.001 copper (Cu) as copper sulphate 0.01 magnesium (Mg) as magnesium phosphate 0.01 manganese (Mn) as manganese sulphate 0.001 boron (B) as boron phosphate 0.001 zinc (Zn) as zinc phosphate 3.0 sulphur (S) as sulphates	James Miller & Co. Pty. Ltd.



MISCELLANEOUS FERTILIZERS—continued

GUARANTEED ANALYSES

Name of Preparation	Percentage Nitrogen (N)	Percentage Phosphorus (P)	Percentage Potassium (K)	Percentage Miscellaneous	Queensland Primary Dealer
Flourish 12-5-10 NPK Resin Coated Slow Release Fertilizer	12.8—ammonium form	4.8—water soluble 0.6—citrate soluble 0.1—insoluble	10.5 as potassium sulphate	0.37 iron (Fe) as ferrous phosphate 0.001 molybdenum (Mo) as ammonium molybdate 0.001 cobalt (Co) as cobalt sulphate 0.001 copper (Cu) as copper sulphate 0.7 magnesium (Mg) as magnesium phosphate 0.01 manganese (Mn) as manganese sulphate 0.001 boron (B) as boron phosphate 0.2 zinc (Zn) as zinc phosphate 3.0 sulphur (S) as sulphates	James Miller & Co. Pty. Ltd.
Nufarm Wuxal Foliar Nutrient Solution	3.7—nitrate form 5.3—ammonium form	3.9—water soluble	4.1 as potassium nitrate 0.8 as potassium sulphate 0.8 as potassium chloride	0.0185 iron (Fe) as iron sulphate 0.006 zinc (Zn) as zinc sulphate 0.016 manganese (Mn) as manganese sulphate 0.0014 nickel (Ni) as nickel sulphate 0.0113 boron (B) as borax 0.0004 cobalt (Co) as cobalt sulphate 0.008 copper (Cu) as copper sulphate 0.00095 molybdenum (Mo) as molybdenum molybdate	Nufarm Chemicals Pty. Ltd.
P.M.B. Organic Garden Mix	0.5 as diammonium phosphate	0.5 as diammonium phosphate	0.4 as potassium sulphate	0.06 magnesium (Mg) as magnesium sulphate 0.1 calcium (Ca) as calcium carbonate 0.005 boron (B) as borax 0.02 copper (Cu) as copper sulphate 0.01 zinc (Zn) as zinc sulphate 0.0008 molybdenum (Mo) as sodium molybdate 0.01 iron (Fe) as iron sulphate 77.2 peanut shells 18.0 molasses	Peanut Marketing Board

## MISCELLANEOUS FERTILIZERS—continued

## GUARANTEED ANALYSES

Name of Preparation	Percentage Nitrogen (N)	Percentage Phosphorus (P)	Percentage Potassium (K)	Percentage Miscellaneous	Queensland Primary Dealer
Nitrosol Vegetable and Flower Grower	1.0 as ammonium sulphate 0.45 as urea 2.8 as meatworks	6.3 as meatworks 0.45 as super-phosphate	2.0 as potassium sulphate	2.5 sulphur (S) as sulphates 14.2 calcium (Ca) as super-phosphate and bone 13.0 water	Products International Pty. Ltd.
Patio and Pot Plant Grower	1.0 as ammonium sulphate 0.45 as urea 2.8 as meatworks	6.3 as meatworks 0.45 as super-phosphate	2.0 as potassium sulphate	2.5 sulphur (S) as sulphates 14.2 calcium (Ca) as super-phosphate and bone 13.0 water	ditto
Animeals Nitrosol Liquid Organic Plant Food	1.0 as ammonium sulphate 0.45 as urea 2.8 as meatworks	6.3 as meatworks 0.45 as super-phosphate	2.0 as potassium sulphate	2.5 sulphur (S) as sulphates 14.2 calcium (Ca) as super-phosphate and bone 13.0 water	Regent Trading Co.
Sandoflor foliar nutrient	1.0 as ammonium sulphate 9.0 as urea	4.4—water soluble	6.2 as potassium phosphate	0.2 maximum biuret 0.013 boron (B) as boric acid 0.002 cobalt (Co) 0.005 copper (Cu) 0.025 iron (Fe) 0.025 magnesium (Mg) 0.005 molybdenum (Mo) 0.013 manganese (Mn) 0.005 zinc (Zn)	Schering Pty. Ltd.
Wuxal Foliar Nutrient Solution	3.7—nitrate form 5.3—ammonium form	3.9—water soluble	4.1 as potassium nitrate 0.8 as potassium sulphate 0.8 as potassium chloride	0.0185 iron (Fe) as iron sulphate 0.006 zinc (Zn) as zinc sulphate 0.016 manganese (Mn) as manganese sulphate 0.0014 nickel (Ni) as nickel sulphate 0.0113 boron (B) as borax 0.0004 cobalt (Co) as cobalt sulphate 0.008 copper (Cu) as copper sulphate 0.00095 molybdenum (Mo) as molybdenum molybdate	Shell Chemical (Aust.) Pty. Ltd.
Animeals Nitrosol Liquid Organic Plant Food	1.0 as ammonium sulphate 0.45 as urea 4.0 as meatworks	0.1 as meatworks 0.45 as super-phosphate	2.0 as potassium sulphate	2.5 sulphur (S) as sulphates 1.7 calcium (Ca) as super-phosphate and bone 34.0 water	Tamborine Mountain Orchids



MISCELLANEOUS FERTILIZERS—continued

GUARANTEED ANALYSES

Name of Preparation	Percentage Nitrogen (N)	Percentage Phosphorus (P)	Percentage Potassium (K)	Percentage Miscellaneous	Queensland Primary Dealer
Trygon Field Pack Fertilizer	0.17 as urea 0.007 as potassium nitrate 0.04 as magnesium nitrate	0.035 as mono-potassium phosphate	0.045 as mono-potassium phosphate 0.023 as potassium nitrate	0.004 boron (B) as boric acid 0.02 calcium (Ca) as calcium chloride 0.02 manganese (Mn) as manganese chloride 0.03 magnesium (Mg) as magnesium nitrate 0.01 iron (Fe) as ferric nitrate 0.001 copper (Cu) as cupric nitrate 0.001 zinc (Zn) as zinc nitrate 0.0025 molybdenum (Mo) as ammonium molybdate 0.0025 maleic acid 0.125 EDTA 0.063 glucose 0.063 sucrose 0.13 succinic acid 0.0025 citric acid 0.0025 tartaric acid 0.2 alkyl-dimethylbenzyl-ammonium chloride 0.3 alkylphenoethoxylate 97.9 water	Trygon Laboratories Pty. Ltd.
Thrive	2.6—as nitrate form 2.2—as ammonium form 26.2 as urea	4.57 water soluble	8.71 as potassium nitrate	0.12 magnesium (Mg) as magnesium sulphate 0.005 copper (Cu) as copper sulphate 0.02 zinc (Zn) as zinc sulphate 0.005 boron (B) as sodium borate 0.04 manganese (Mn) as manganese sulphate 0.002 molybdenum (Mo) as sodium molybdate 0.064 sulphur (S) as sulphates	Arthur Yates & Co. Pty. Ltd.
Yates Acitone	5.25—ammonium form	..	..	18.22 sulphur (S) as sulphates 25.0 sulphur (S) as elemental sulphur 3.9 aluminium (Al) as aluminium sulphate 9.2 iron (Fe) as iron sulphate	ditto

## MISCELLANEOUS FERTILIZERS—continued

GUARANTEED ANALYSES					
Name of Preparation	Percentage Nitrogen (N)	Percentage Phosphorus (P)	Percentage Potassium (K)	Percentage Miscellaneous	Queensland Primary Dealer
Yates Daphne and Rhododendron Food Tonic	0.42 as nitrate form 2.52 as ammonium form 1.8 as urea 0.6 as blood and bone 1.38 as vegetable meal	0.53—citrate soluble 4.81—insoluble	1.65 as potassium nitrate 0.31 as potassium sulphate	2.88 sulphur (S) as sulphates 0.32 magnesium (Mg) as magnesium sulphate 0.085 zinc (Zn) as zinc sulphate 0.078 copper (Cu) as copper sulphate 0.003 molybdenum (Mo) as sodium molybdate 0.16 manganese (Mn) as manganese sulphate 0.002 iron (Fe) as iron chelates 0.019 boron (B) as borax 60.0 fine material 40.0 coarse material	Arthur Yates & Co. Pty. Ltd.
Yates Hydrangea Blueing Tonic	1.6—ammonium form	..	3.82 as potassium nitrate	24.6 sulphur (S) as sulphates 1.37 aluminium (Al) as aluminium sulphate	ditto
Yates Orchid Food	2.6 as nitrate form 2.2 as ammonium form 26.2 as urea	4.57—water soluble	8.71 as potassium nitrate	0.12 magnesium (Mg) as magnesium sulphate 0.064 sulphur (S) as sulphates 0.005 copper (Cu) as copper sulphate 0.02 zinc (Zn) as zinc sulphate 0.005 boron (B) as sodium borate 0.04 manganese (Mn) as manganese sulphate 0.002 molybdenum (Mo) as sodium molybdate 0.015 iron (Fe) as ferric ethylenediamine di (o-hydroxyphenylacetate)	ditto
Yates Slow Release Plant Pills	14.0 as urea formaldehyde	1.82—water soluble 0.2—citrate soluble 0.2—insoluble	4.98 as potassium sulphate	6.0 calcium (Ca) as super-phosphate 5.0 sulphur (S) as sulphates 0.3 iron (Fe) as iron sulphate	ditto



## TRACE ELEMENTS

Name of Preparation	Guaranteed Analysis—Percentage	Queensland Primary Dealer
<i>Aluminium—</i>		
Hortico Aluminium Sulphate .. .. .	8.0 aluminium (Al) as aluminium sulphate ..	Hortico (Qld) Pty. Ltd.
Agrico Sulphate of Aluminium .. .. .	14.0 sulphur (S) as aluminium sulphate ..	
	8.0 aluminium (Al) as aluminium sulphate ..	Lane Ltd.
	14.0 sulphur (S) as aluminium sulphate ..	
<i>Boron—</i>		
ACF—Austral Borax .. .. .	11.3 boron (B) as sodium borate .. .. .	Consolidated Fertilizer Sales Pty. Ltd.
<i>Copper—</i>		
ACF—Austral Bluestone (Copper Sulphate) ..	25.0 copper (Cu) as copper sulphate .. .. .	ditto
	12.6 sulphur (S) as copper sulphate .. .. .	
ESA Bluestone Granulated .. .. .	25.0 copper (Cu) as copper sulphate .. .. .	Elder Smith Goldsbrough Mort Ltd.
Hortico Bluestone Copper Sulphate .. .. .	25.0 copper (Cu) as copper sulphate .. .. .	Hortico (Qld) Pty. Ltd.
	12.0 sulphur (S) as copper sulphate .. .. .	
<i>Iron—</i>		
Barmac Greenfinger Fersulph .. .. .	19.7 iron (Fe) as ferrous sulphate .. .. .	Barnes McGrath Pty. Ltd.
	11.0 sulphur (S) as ferrous sulphate .. .. .	
Sequestrene 138 Fe Iron Chelate .. .. .	6.0 iron (Fe) as technical sodium ferric ethylenediamine di (O-hydroxy phenylacetate)	Ciba-Geigy Australia Ltd.
ACF—Austral Sulphate of Iron .. .. .	19.7 iron (Fe) as iron sulphate .. .. .	Consolidated Fertilizer Sales Pty. Ltd.
	11.5 sulphur (S) as iron sulphate .. .. .	
Garden King Iron Chelate .. .. .	5.0 iron (Fe) as iron complex of EDTA ..	ditto
Hortico Chelated Iron .. .. .	12.0 iron (Fe) as iron sodium ethylenediamine tetra acetic acid	Hortico (Qld) Pty. Ltd.
Hortico Sulphate of Iron .. .. .	20.0 iron (Fe) as iron sulphate .. .. .	ditto
	11.5 sulphur (S) as iron sulphate .. .. .	
Lane Sulphate of Iron .. .. .	20.0 iron (Fe) as ferrous sulphate .. .. .	Lane Ltd.
	11.4 sulphur (S) as ferrous sulphate .. .. .	
<i>Magnesium—</i>		
Barmac Greenfinger Sulmag .. .. .	9.8 magnesium (Mg) as magnesium sulphate ..	Barnes McGrath Pty. Ltd.
	13.0 sulphur (S) as magnesium sulphate ..	
ACF—Austral Granomag AL7 .. .. .	54.0 magnesium (Mg) as magnesium oxide ..	Consolidated Fertilizer Sales Pty. Ltd.
ACF—Austral Magnesium Sulphate .. .. .	9.6 magnesium (Mg) as magnesium sulphate ..	ditto
	12.4 sulphur (S) as magnesium sulphate ..	
Hortico Magnesium Sulphate (Epsom Salts) ..	9.0 magnesium (Mg) as magnesium sulphate ..	Hortico (Qld) Pty. Ltd.
	13.0 sulphur (S) as magnesium sulphate ..	
Agrico Magnesium Sulphate (Epsom Salts) ..	9.8 magnesium (Mg) as magnesium sulphate ..	Lane Ltd.
	12.8 sulphur (S) as magnesium sulphate ..	
<i>Manganese—</i>		
ACF—Austral Manganese Sulphate .. .. .	25.5 manganese (Mn) as manganese sulphate ..	Consolidated Fertilizer Sales Pty. Ltd.
	14.9 sulphur (S) as manganese sulphate ..	
Agrico Manganese Sulphate .. .. .	32.0 manganese (Mn) as manganese sulphate ..	Lane Ltd.
	18.5 sulphur (S) as manganese sulphate ..	

## TRACE ELEMENTS—continued

Name of Preparation	Guaranteed Analysis—Percentage	Queensland Primary Dealer
<i>Molybdenum—</i>		
ACF—Austral Sodium Molybdate .. .. .	33.0 molybdenum (Mo) as sodium molybdate .. .. .	Consolidated Fertilizer Sales Pty. Ltd.
ACF—Austral Molybdenum Trioxide .. .. .	30.0 molybdenum (Mo) as molybdenum trioxide .. .. .	ditto
Agrico Sodium Molybdate .. .. .	39.0 molybdenum (Mo) as sodium molybdate .. .. .	Lane Ltd.
Chem Air Sodium Molybdate .. .. .	39.0 molybdenum (Mo) as sodium molybdate .. .. .	Chemicals and Air Services Pty. Ltd.
<i>Sulphur—</i>		
ACF—Austral Powdered Sulphur .. .. .	99.0 sulphur (S) as powdered sulphur .. .. .	Consolidated Fertilizer Sales Pty. Ltd.
Crop King Sulphur .. .. .	99.5 sulphur (S) as sulphur .. .. .	ditto
<i>Zinc—</i>		
ACF—Austral Zinc Sulphate .. .. .	22.7 zinc (Zn) as zinc sulphate .. .. . 11.0 sulphur (S) as zinc sulphate	Consolidated Fertilizer Sales Pty. Ltd.
Hardman Nuzinc .. .. .	65.0 zinc (Zn) as sulphated zinc oxide .. .. . 3.0 sulphur (S) as sulphated zinc oxide	ditto
Leffingwell Nutraspray Zinc 50 .. .. .	31.0 zinc (Zn) as zinc sulphate .. .. . 19.0 zinc (Zn) as zinc oxide 4.6 calcium (Ca) as calcium sulphate 10.0 sulphur (S) as sulphates	General Fertilizers Ltd.
Agrico Zinc Sulphate .. .. .	22.7 zinc (Zn) as zinc sulphate .. .. . 11.0 sulphur (S) as zinc sulphate	Lane Ltd.
<i>Mixtures—</i>		
Barmac Greenfinger Tracel Supplemental Additive	8.0 copper (Cu) as copper oxychloride .. .. . 0.9 zinc (Zn) as zinc sulphate 1.4 manganese (Mn) as manganese sulphate 1.56 molybdenum (Mo) as sodium molybdate 0.84 cobalt (Co) as cobalt sulphate 4.8 iron (Fe) as ferrous sulphate 17.5 potassium (K) as potassium sulphate 12.0 sulphur (S) as sulphates	Barnes McGrath Pty. Ltd.
Leffingwell Nutraspray ZM25–25 .. .. .	20.0 zinc (Zn) as zinc oxide .. .. . 5.0 zinc (Zn) as zinc carbonate 25.0 manganese (Mn) as manganese carbonate	General Fertilisers Ltd.
Hortico Complete Trace Elements .. .. .	23.01 potassium (K) as potassium sulphate .. .. . 1.66 magnesium (Mg) as magnesium sulphate 2.24 manganese (Mn) as manganese sulphate 0.88 copper (Cu) as copper sulphate 0.78 zinc (Zn) as zinc sulphate 0.19 boron (B) as borax 0.012 molybdenum (Mo) as sodium molybdate 12.88 sulphur (S) as sulphates	Hortico (Qld) Pty. Ltd.



## Addresses and Telephone Numbers of Queensland Primary Dealers Appearing in this List

Acacia Nurseries	84 Benhiam St., Calamvale. Q. 4116 Telephone (07)-273 1551
Barnes McGrath Pty. Ltd.	Cnr. Annie and Dawn Sts., Rocklea. Q. 4106 Telephone (07)-277 3999
BASF Australia Ltd.	17 Jaybel St., Salisbury North. Q. 4107 Telephone (07)-275 3077
Bayer Australia Ltd.	1101 Beaudesert Rd., Coopers Plains. Q. 4108 Telephone (07)-277 3899
Thomas Borthwick & Sons (A'asia) Ltd.	Murarrie. Q. 4172 Telephone (07)-390 4144
Burnell Agencies	40a Milsom St., Coorparoo. Q. 4151 Telephone (07)-398 8688
Chemical & Air Services Pty. Ltd.	34 Gladstone St., Moorooka. Q. 4105 Telephone (07)-277 2022
Chemsearch Australia Pty. Ltd.	Representative Mr. James E. Smith, Hancock, Woodward & Neill, Empire House, Cnr. Queen and Wharf Sts., Brisbane. Q. 4000. Telephone (07)-221 2011
Ciba-Geigy Australia Ltd.	Cnr. Kurilpa St. and Montague Rd., West End. Q. 4101 Telephone (07)-44 6864
Colin Campbell (Chemicals) Pty. Ltd.	Representative Mr. R. J. Osborne, 42 Glenvale Rd., Toowoomba. Q. 4350 Telephone (076)-34 3924
Consolidated Fertilizer Sales Pty. Ltd.	Gibson Island, Hemmant. Q. 4174 Telephone (07)-390 5011
Elder Smith Goldsbrough Mort Ltd.	2 Felix St., Brisbane. Q. 4000 Telephone (07)-31 2231
Galdonost Dynamics N.Z. Ltd.	143 Dunedin St., Sunnybank. Q. 4109 Telephone (07)-345 4501
General Fertilisers Ltd.	1808 Ipswich Rd., Rocklea. Q. 4106 Telephone (07)-277 3755
Hoechst Australia Ltd.	375 Montague Rd., West End. Q. 4101 Telephone (07)-44 3661
Hortico (Qld.) Pty. Ltd.	911 Lytton Rd., Murarrie, Q. 4172 Telephone (07)-390 5888

Hutton Brothers	91 Heeney St., Chinchilla. Q. 4413 Telephone Chinchilla 79
Lane Limited	261 Tingira St., Pinkenba. Q. 4008 Telephone (07)-260 1091
Mangan Brothers	Fitzroy St., Warwick. Q. 4370 Telephone (076)-61 1336
James Miller and Co. Pty. Ltd.	19 Lytton Rd., East Brisbane. Q. 4169 Telephone (07)-391 3711
Nufarm Chemicals Pty. Ltd.	726 Kingsford Smith Drive, Hamilton. Q. 4007 Telephone (07)-268 6551
Peanut Marketing Board	Haly St., Kingaroy. Q. 4610 Telephone (074)-72 2211
Products International Pty. Ltd.	23 Kingsway St., Mt. Gravatt. Q. 4122 Telephone (07)-349 9578
Regent Trading Company	26 Grove St., Albion. Q. 4010 Telephone (07)-57 5846
Schering Pty. Ltd.	54 Annie St., Rocklea. Q. 4106 Telephone (07)-275 1774
Shell Chemical (Aust.) Pty. Ltd.	Shell House, 301 Ann St., Brisbane. Q. 4000 Telephone (07)-226 5301
Tamborine Mountains Orchids	Long Rd., Eagle Heights. Q. 4271 Telephone (075)-45 1303
Trygon Laboratories Pty. Ltd.	9 Katrina Avenue, Rochedale. Q. 4123 Telephone (07)-341 6391
Arthur Yates & Co. Pty. Ltd.	Bronze St., Sumner Park. Q. 4074 Telephone (07)-376 3433





# Subscribe Now

# "The Queensland Agricultural Journal"

## Concession rates available

Persons eligible for concession rate include commercial farmers whose principal source of income is from primary production, students of agricultural courses, libraries and educational institutions (all resident in Queensland). Students' applications should be endorsed by the lecturer or teacher.

---

## QUEENSLAND AGRICULTURAL JOURNAL ORDER FORM

### Subscription Rates—

Ordinary — \$6.90 per annum (Australian Currency)

Concession rate — \$2.30 per annum

NAME Mr.....  
Mrs.....  
Miss..... (SURNAME IN BLOCK LETTERS) INITIALS.....

PRESENT ADDRESS..... POSTCODE.....

PREVIOUS ADDRESS (if applicable).....

OCCUPATION.....

I hereby enclose \$ ..... for ..... years subscription (2 year limit).

New Subscriber

Renewal

(Tick the one that applies)

Signature.....

Office Use Only

# Historical engineering relics

THE Department of Primary Industries is represented on the Historical Engineering Relics Sub-committee of the Institution of Engineers, Australia.

The objective of the group is to assist in the preservation and/or recording of historical engineering relics, documents and sites. Special attention is being given to securing photographs and written records where the demolition or destruction of items of historical interest is inevitable.

Provision has been made for the Queensland Museum to act as a collecting point for information gathered.

In an endeavour to record the engineering history of Queensland with particular reference to the agricultural and pastoral industries, the Department will be grateful to receive information from readers of the Q.A.J. concerning engineering artifacts, equipment or machinery.

The data being recorded are shown on cards reproduced below.

All contributions to these records will be acknowledged and appreciated. Please forward information to the Department's representative: G. H. Allen, Department of Primary Industries, William Street, Brisbane, Q. 4000.

## HISTORICAL ENGINEERING RELICS

NATURE OF RELIC		IN DANGER OF DEMOLITION DAMAGE YES/NO
LOCATION (Address or Map and Grid Ref.)	INDUSTRY	STATE OF REPAIR
DESCRIPTION (Dimensions, Special Features, Particulars of Construction)		
(Further remarks or sketch may be recorded on back or photographs attached)		
PURPOSE FOR WHICH NOW USED:		
DATE OF MANUFACTURE/CONSTRUCTION:	MAKE/MANUFACTURER:	
LOCATION OF ANY PLANS, REPORTS, ETC.		
EXTENSIONS OR RENOVATIONS/MODIFICATIONS:		DATE:
EXTENT:		
NAME AND ADDRESS OF OWNER:		
REPORTED BY:	DATE:	PLEASE RETURN TO:— G. H. ALLEN, DEPARTMENT OF PRIMARY INDUSTRIES, WILLIAM STREET, BRISBANE, Q. 4000.  FOR ULTIMATE RETURN TO: THE INSTITUTION OF ENGINEERS, AUSTRALIA 447 UPPER EDWARD STREET, BRISBANE, Q. 4000.
ADDRESS:		



# Diseases of the *Heliothis* caterpillar

WE are accustomed to thinking of disease as being harmful to crops. However, there are beneficial diseases which are helping to protect crops. They do this by attacking certain insect pests.

The *Heliothis* caterpillar, which is probably our most serious agricultural insect pest, suffers from a range of diseases. These diseases may slow down the development of *Heliothis* populations or, under favourable conditions, may destroy potentially damaging populations.

They tend to be relatively specific, self-perpetuating and environmentally non-harmful. Furthermore, they are not directly affected by the use of chemical insecticides, unlike some other forms of natural control. Hence the Department of Primary Industries is studying insect diseases to learn how they operate and can be manipulated to give control. In the United States, a preparation of one virus specific for *Heliothis* has already been registered as an insecticide.

Obviously, natural disease cannot normally be relied on to give control. Nevertheless, farmers should be aware of the appearance of the diseased insects as their presence may indicate that chemical control is not required. In some instances, diseased caterpillars, collected and stored under refrigeration, could be used to protect later crops from *Heliothis* attack.

Five diseases of the *Heliothis* caterpillar have been recorded in Queensland.

1. Nuclear polyhedrosis virus (NPV) disease. This is usually the most destructive of the diseases and is commonly recorded on lucerne, peanuts and sorghum. The disease is acquired when caterpillars eat contaminated food.

Infected caterpillars are usually located near the top of the plant. At death, they are soft and 'squashy' and rupture readily, releasing enormous numbers of virus particles. Hence the disease spreads rapidly, particularly

when the plant is wet. A very similar virus is produced commercially for bollworm control in the United States.

2. Granulosis virus disease. This disease is often associated with *Heliothis* caterpillars but it does not normally spread so rapidly through the *Heliothis* population. The infected caterpillars, which are pale or creamy coloured, survive for a relatively long period. After death, the skin tends to remain intact, retarding the release of the virus.

3. *Nosema heliothidis* protozoan disease. This disease is more debilitating to *Heliothis* populations. It usually acts by slowing down caterpillar development and by causing the moths to produce fewer eggs. The disease can be transmitted to offspring through the egg or acquired through contaminated food. Caterpillars killed by the disease have a creamy appearance similar to those with granulosis virus disease.

4. *Nomuraea rileyi* fungus disease. This fungus attacks a range of caterpillars, including *Heliothis*, when moist conditions occur. *Heliothis* on soybeans, maize, sorghum and other crops are commonly infected. To infect, the fungal spores stick to the surface of the insect, germinate and penetrate the skin. The insect initially becomes stiff and eventually covered by a white fungus and then a green, velvety layer containing masses of spores.

5. *Beauveria bassiana* fungus disease. This fungus attacks a wide range of insects, including *Heliothis*. Moist conditions are also required for infection. The infected caterpillars become stiff and enveloped in a white, fluffy mass.

by R. E. Teakle,  
Entomology Branch.

For diagnosis and further information, diseased specimens may be forwarded direct, or through your local adviser, to the Director, Entomology Branch, Department of Primary Industries, Meiers Road, Indooroopilly, Q. 4068.

# Diseases of the *Heliothis* caterpillar



Nuclear polyhedrosis virus (NPV) disease.

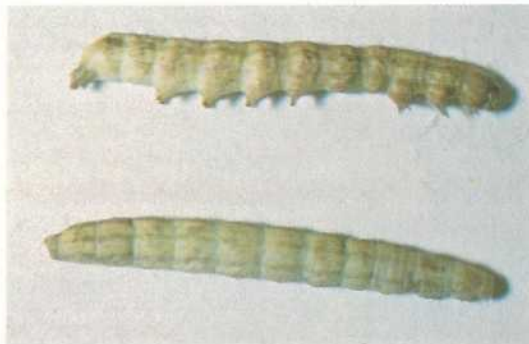

Granulosis virus disease.



*Nosema heliothidis* (protozoan) disease (lower caterpillar). Upper caterpillar healthy.



*Nomuraea rileyi* fungus disease, before and after spore development.



*Beauveria bassiana* fungus disease (right caterpillar).