

*Queensland*  
**AGRICULTURAL  
JOURNAL**

May-June 1978 Vol. 104 No. 3



# DEPARTMENT OF PRIMARY INDUSTRIES

<b>Director-General</b>	A. A. Ross
Deputy Director-General	E. O. Burns
Chief Advisory Officer (Administration)	Dr. G. I. Alexander
Assistant Under Secretary	H. J. Evans
Assistant to Director-General	A. Winterton
Director, Information and Extension Training Branch	J. L. Groom
Executive Officer, Central Administration	K. G. Trudgian
Chief Biometrician	C. P. Hamilton
Executive Officer, Research Stations Section	G. H. Allen
Executive Officer, Extension Services Section	J. Gibb

<b>Director, Division of Plant Industry</b>	B. L. Oxenham
Deputy Director	N. F. Fox
Director of Agriculture	Dr. J. K. Leslie
Director of Horticulture	H. M. Groszmann
Director, Botany Branch	Dr. R. W. Johnson
Director, Entomology Branch	T. Passlow
Director, Plant Pathology Branch	G. S. Purs
Director, Agricultural Chemistry Branch	T. J. Beckmann

<b>Director, Division of Land Utilisation</b>	A. Hegarty
Deputy Director	H. W. Pauli
Director, Development Planning Branch	W. F. Y. Mawson
Director of Soil Conservation	H. S. Pink

<b>Director, Division of Animal Industry</b>	L. G. Newton
Deputy Director (Research)	J. W. Ryley
Deputy Director (Field Services)	B. A. Woolcock
Director of Veterinary Services	K. M. Grant
Director, Biochemistry Branch	C. W. R. McCray
Director of Husbandry Research	L. Laws
Director of Pathology (A.R.I.)	W. T. K. Hall
Director of Sheep Husbandry	A. T. Bell
Director, Beef Cattle Husbandry Branch	M. R. E. Durand
Director, Slaughtering and Meat Inspection Branch	B. Parkinson
Director, Pig and Poultry Branch	F. N. J. Milne

<b>Director, Division of Dairying</b>	V. R. Smythe
Deputy Director	W. D. Mitchell
Director of Research	
Director of Field Services	G. G. Crittall
Director, Dairy Cattle Husbandry Branch	I. H. G. Rayner

<b>Director of Marketing</b>	D. P. Lapidge
Deputy Director	A. C. Peel
Director of Economic Services	R. B. Bygott
Director of Marketing Services	D. R. J. Densley
Director of Agricultural Standards	W. V. Mungomery



*Harvesting wheat on 'Poondarra'—D. Barlow's property at Yandilla. See 'A four-wheel-drive field bin saves time and money' in this issue. Photograph—B. Rogers.*

# QUEENSLAND AGRICULTURAL JOURNAL

Vol. 104 No. 3

May-June 1978

Editor, P. R. Lee

## Contents

	page
Horned cattle at Cannon Hill by W. J. A. Hall .. .. .	210
A four-wheel-drive field bin saves time and money by I. N. McClement .. .. .	213
Control buffalo flies with this new back rubber by K. S. Waters .. .. .	215
Pastures for the Gympie district . . . part 3 by B. G. Cook .. .. .	226
The lawn armyworm . . . a serious rural and urban pest by R. H. Broadley .. .. .	232
Electric fence controls wallabies by K. F. Howard .. .. .	237
Lupins in the South Burnett by A. Hodge .. .. .	239
Joining wall to floor by H. Woodings .. .. .	244
Creeping bluegrass finds favour by W. J. Bisset and T. G. Graham .. .. .	245
Chemical weed control guide—winter cereals 1978 by S. R. Walsh and J. M. T. Marley .. .. .	254
Macadamia pests . . . fruit-spotting bug and banana-spotting bug by D. A. Ironside .. .. .	xiii
Safflower variety testing—what's happening? by K. J. Jackson .. .. .	257
New fertilizer distributor . . . a cost saver by P. E. Page .. .. .	264
Home ram breeding by D. M. Allison and D. J. Jordan .. .. .	267
Sunflower growing—a changing industry by N. E. Delaney .. .. .	269
Bovine Brucellosis accredited—free stud herd scheme .. .. .	278
Sugarcane mosaic virus in sorghum by D. M. Persley .. .. .	279
Milkfat . . . what is it? by J. W. Aston .. .. .	282
Wheat and Barley variety testing in central Queensland by G. A. Thomas and J. H. Ladewig .. .. .	285
Water-tight concrete by H. Woodings .. .. .	288
Identifying insects—Order Lepidoptera part 2—moths by B. K. Cantrell .. .. .	289
Identifying insects—moths by B. K. Cantrell .. .. .	xvii
Cookery .. .. .	302

The *Queensland Agricultural Journal* is published every second month by the Department of Primary Industries, William Street, Brisbane, Queensland, 4000. Telephone 224 0414.

Note to Editors—Articles in the *Queensland Agricultural Journal* are protected by copyright. Editors are invited to use material from the *Journal* if they acknowledge both the author and the *Queensland Agricultural Journal*.

# Horned



*Dehorning in the 1890s—primitive and painful.*

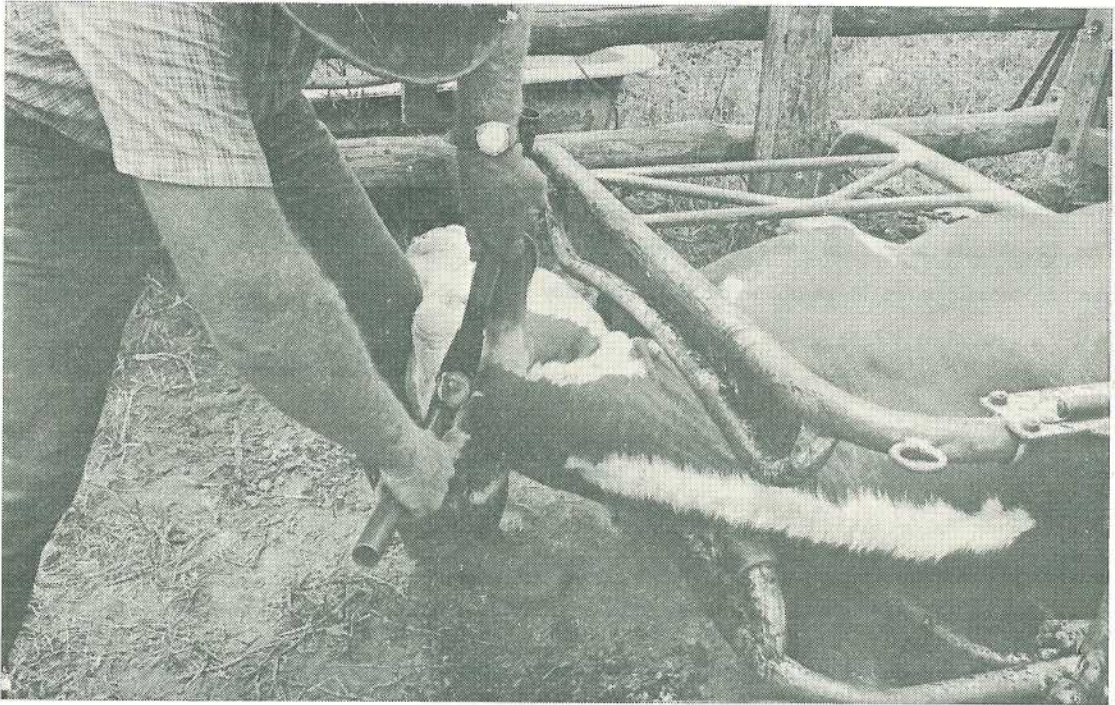

*Dehorning in the 1970s—quick and profitable.*

# cattle at Cannon Hill

by W. J. A. HALL, Beef Cattle Husbandry Branch.

HALF of the bruising in beef carcasses is believed to be directly caused by horns.

A recent study at Brisbane's Cannon Hill saleyards highlighted the significance of horned cattle.

## Effects of horns on price

The evidence collected showed that pens of all hornless cattle attracted a 1.6% higher price than mixed pens. Pens of all horned cattle received a 2.0% lower price than the mixed pens.

In other words, if two groups of cattle of a similar type, condition score and weight range (one group all horned and the other one all hornless) are presented at the same sale, the hornless cattle will probably attract a premium of 3.6%.

For example, if the average price is \$100 per head the producer is likely to be paid an extra \$3.60 per head for dehorning the whole group.

Dehorning should be carried out at branding to minimize the effects on the animal.

## Extent of horned cattle

Of 24 783 head observed, 37.8% were horned and 62.2% were hornless.

Cattle in the hornless group were either polled or dehorned. Hornless cattle made up 65.2% of the British breeds, 56.0% of the Zebu breeds and 68.1% of the dairy breeds.

Table 1 shows horn status by type of animal. Fewer horns were present on younger cattle suggesting that dehorning may be on the increase. The tradition of leaving bulls horned apparently remains strong.

Figure 1 shows the regional differences in the supply of horned cattle but these figures may be complicated by the distribution of breeds. An analysis of these differences according to regional supply suggests that 44.0% of Queensland's cattle are in fact horned.

TABLE 1  
HORN STATUS X ANIMAL TYPE

	Horned		Untipped	
	%	No.	%	No.
Cows .. ..	36.5	2 879	56.0	1 611
Steers, bullock, ox	40.8	4 245	38.2	1 620
Heifers .. ..	28.9	795	46.3	368
Yearlings vealers	30.3	183	80.9	148
Bulls .. ..	68.1	203	62.6	127

## Extent of tipping

Of the horned cattle studied, 36.2% were lightly tipped and 14.1% were heavily tipped. Research has shown that tipping is ineffective in reducing bruising. Tipping was most common among the British breeds (53.1%) and slightly less frequent among the Zebu-infused breeds (49.4%). Only 26.4% of the horned dairy breed cattle were tipped.

Figure 1 shows the distribution of tipped cattle in Queensland. An analysis of regional supply shows that 48.1% of the State's horned cattle are probably tipped.

## Mixing horned and hornless cattle

In most saleyards, it is impractical to keep horned and hornless cattle separate. The mixing of horned and hornless stock may occur on the property, in the selling pen or after weighing in the buyers' pen before trucking. The degree of mixing is important because trials have shown that hornless cattle are likely to have similar amounts of bruising to horned cattle when they are mixed together.

From the producer's point of view, the likelihood of selling a hornless group at auction without getting them mixed up with horned cattle was only 2.0% or one chance in fifty. Put another way, the producer who conscientiously dehorned to minimize bruising and then sells through the saleyard will find that 98 times out of 100 his hornless cattle will be penned up with horned cattle at some time.

The author wishes to acknowledge the considerable assistance of Mr R. A. Jurgensen, Marketing Services Branch, and Mr A. J. Swain, Biometry Branch.

Figure 1.



Moreton Region

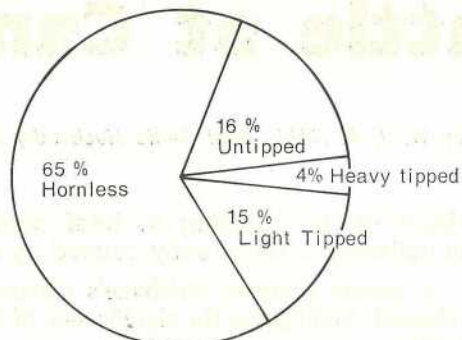

Wide-Bay. Burnett

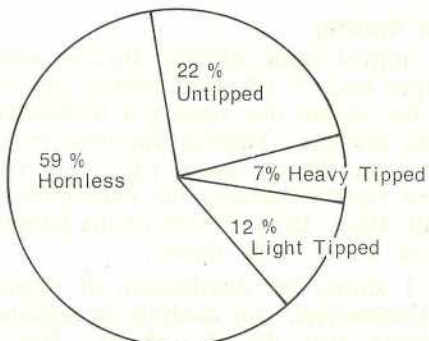

Darling Downs

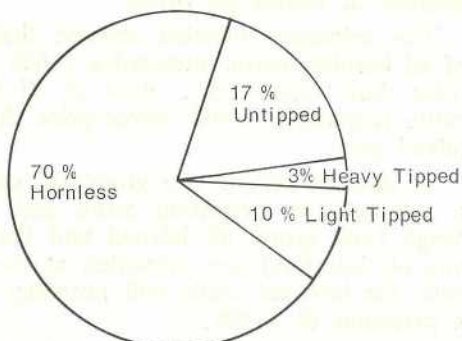

South-west

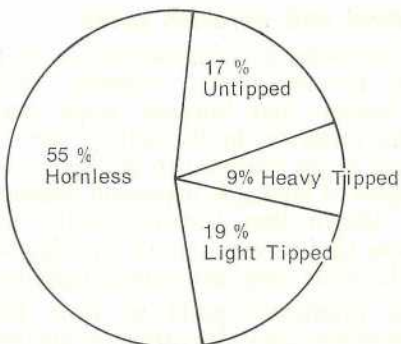

Fitzroy

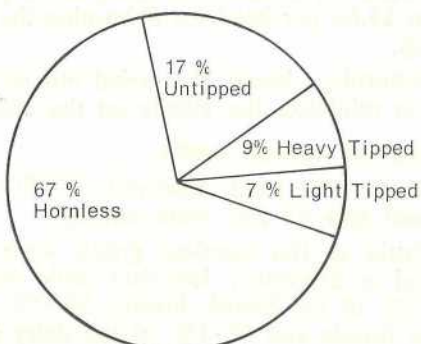

Central-west \*

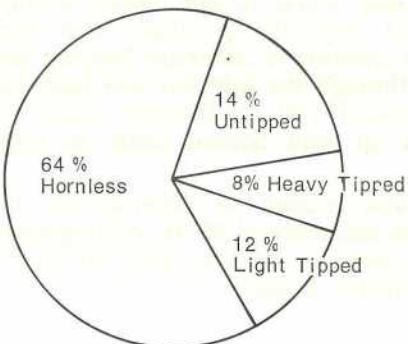

Mackay \*

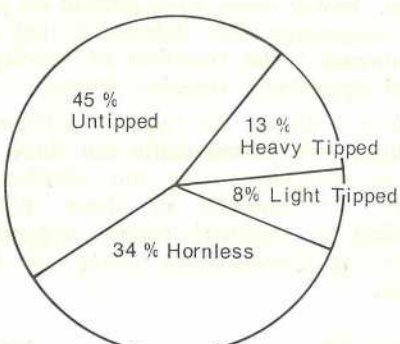

Northern \*

\* Limited Numbers Presented

# A four-wheel-drive field bin



## saves time and money

by I. N. McCLEMENT, Agriculture Branch.

DON BARLOW, an enterprising grain grower at Yandilla on the central Darling Downs, has designed and constructed a four-wheel-drive field bin.

This bin was designed to transport grain across extremely boggy conditions to farm storages and has drastically cut travelling time and running costs.

While many grain growers experience difficulty in removing grain from paddocks following rain at harvest time, their problems are not as severe as grain growers on the terraces adjoining the Condamine River.

On these properties, it is not uncommon to find grain-producing areas on the farm cut off from farm storages by depressions and old water-courses filled with water and silt.

According to Don Barlow, wet weather in the past has meant an extra 12 km per trip from the header to farm storage. Using the conventional means of transporting grain by truck meant smaller loads, slower travelling, high fuel usage and a high risk of mechanical damage to the trucks.

*Photograph above. Overall view of the grain bin mounted between two tractors. The controls used to regulate the second tractor's engine can be seen passing over the seat of the first tractor.*

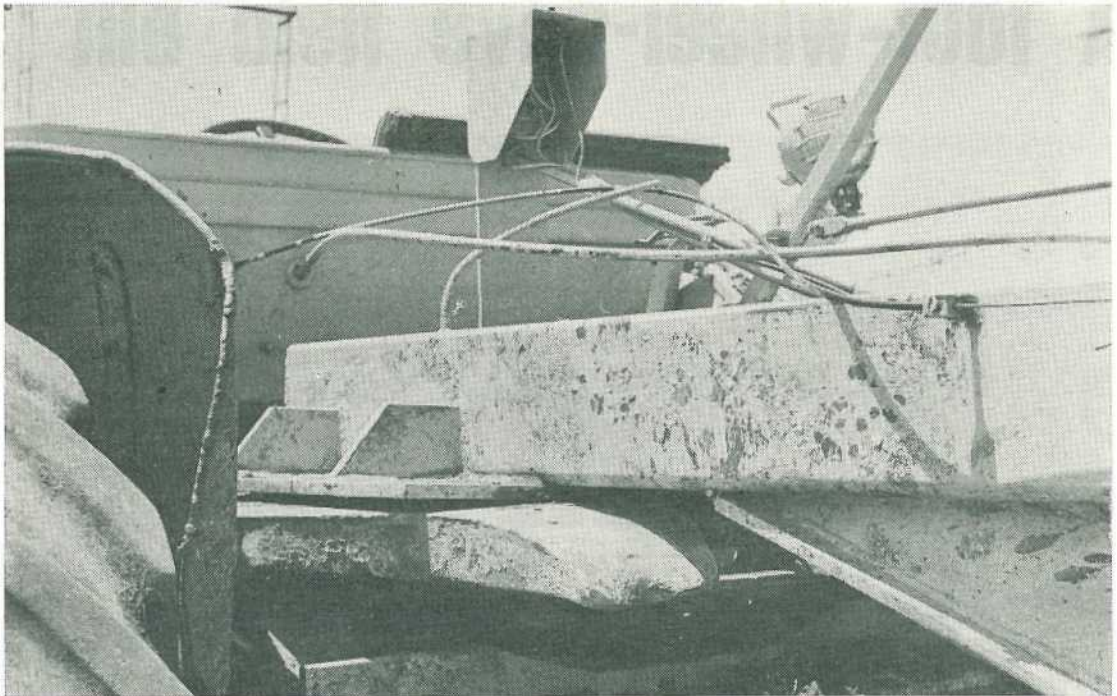

*Close-up of the quick-action semi-trailer hitch which connects the front tractor to the grain bin.*

During the 1976-77 season, the four-wheel-drive field bin was brought into service for the first time. It reduced travelling time and costs and removed the necessity to have a tractor on standby to tow bogged trucks.

A 7 tonne grain bin is built on a frame which is mounted between two diesel tractors. The trailing portion of the bin is attached to the rear of the front tractor by a semi-trailer hitch. This means the front tractor can be released for other farm work in less than 5 minutes.

While no provision has been made to release the rear tractor, Don Barlow says a few modifications to his design could release this tractor in a few minutes for other farm duties.

Two standard Chamberlain farm tractors were selected as power units for the grain bin. The speeds of the engines are synchronized by controlling the fuel pumps on both tractors by means of inner and outer cables and the engines remain in unison irrespective of the positions of the tractors during travelling and manoeuvring.

The clutch on the leading tractor is attached to the clutch on the rear tractor by means

of inner and outer cables—so the operator in effect is really only driving one tractor.

Don Barlow has now reduced the harvest to a three man operation, one header driver, one bin operator and a truck driver to deliver grain to the depot.

The harvest averages 16 tonnes per hour and no delays are experienced emptying into the bin despite a travelling distance of 2 km to the truck waiting on a gravel road.

Bringing this four-wheel-drive field bin into service has meant a saving of 2 weeks in the time taken to harvest a crop during a wet season.

Built on the Barlow property 'Poondarra', Don estimates the time for construction as 4 months. However, he is quick to point out that the work was carried out in spare time during that period.

Total cost of the materials including the tractors was \$4700, but this does not include labour costs. However, if the four-wheel-drive grain bin saves 2 weeks per harvest Don Barlow feels sure his labour costs will be off-set in 2 years.



# Control buffalo flies with this new back rubber

by K. S. WATERS, Veterinary Services Branch.

MANY cattlemen are quick to point out that they are more concerned with buffalo fly infestations than with cattle ticks.

This view often comes from men who have Brahman cross herds which have far higher tick resistance than British cattle.



Above. Mr A. Knuth of 'Virginia Park', Charters Towers claims that his bullocks are producing better weights since using back rubbers.

Below. A back rubber on the Reid Brothers' property 'Burnside', Ingham.

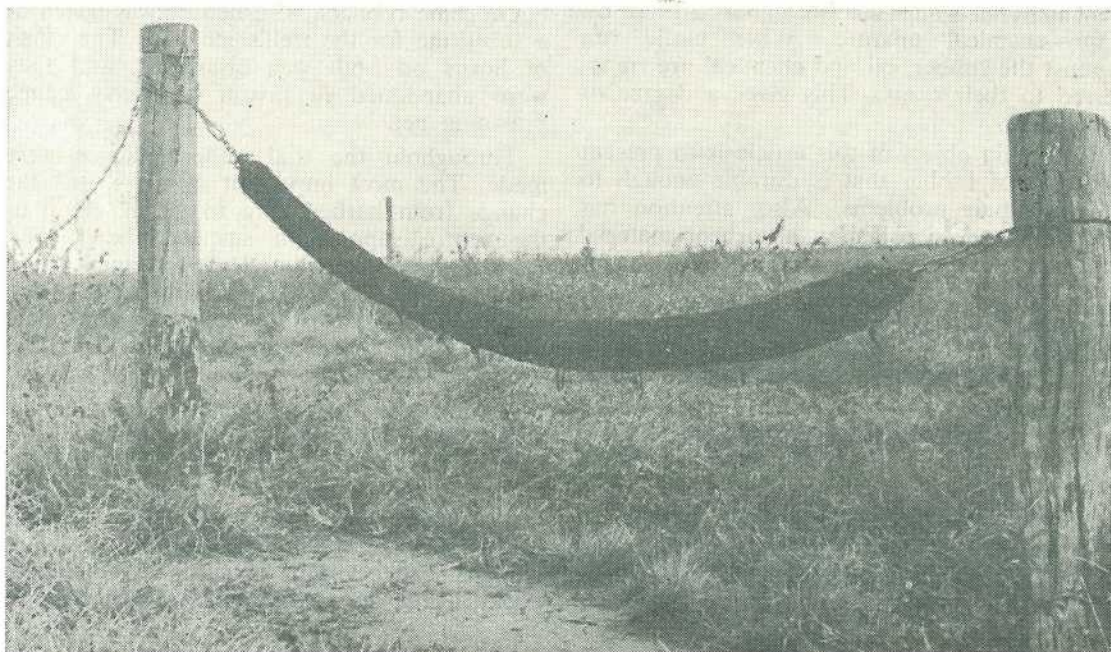

Do buffalo flies cause a loss to cattle production? Cattlemen think they do. Cattle infested with buffalo fly certainly look worse than cattle free of flies. Some research workers argue that loss of beef production due to fly infestations may be insignificant. It is technically difficult and costly to settle this argument. Until then, we have to 'put the cart before the horse' by using control measures such as overspraying, dipping, back rubbers or dust bags.

The flies' non-parasitic period in dung pads is 7 to 11 days while the parasitic stage of the life cycle takes 10 to 20 days. To control flies by overspraying or dipping with suitable chemicals, the life cycle at the parasitic stage has to be cut. This involves short interval treatments which are either too costly or impractical. This is a very short term relief. New chemicals which give a protection period of 12 to 14 days are required to cut the life cycle of the fly. There are some promising chemicals under investigation.

Peak fly infestations occur during the summer months. Mustering cattle for overspraying or dipping is expensive and during the wet season mustering is sometimes impossible. Back rubbers make a worthwhile substitute for fly control. They are cheaper because mustering is not required.

A back rubber basically consists of absorbent material which has been soaked in an oil base—chemical mixture. When cattle rub against the rubber, oil and chemical are transferred to their coats. This gives a degree of fly control.

The main object of this article is to present a design of rubber that is durable enough to reduce repair problems. Also, attention has been directed to using an absorbent material that will hold the oil-chemical mixture for long periods.

In the past, cattlemen have attempted to use rubbers made of hemp bags which were suspended by barbed wire between two trees; but durability was poor. Often, rubbers lasted no more than 6 weeks before repairs were required. Also, hemp bags became scarce. These two problems prompted the need to test other materials and design a better rubber.

Successful fly control has been demonstrated by D. F. Mahoney in the Ingham and Townsville areas. A trial in the Cairns area in 1967

indicated a 4 to 5 in. roll held sufficient chemical and oil to treat cattle and also resisted water saturation during the wet season.

## Trials

With this background work, trials were commenced in the Townsville area in January, 1973 on the properties of Mr E. Bell and Mr A. Buck. The length of rubber used on each place was 12 ft. and 10 ft. respectively. Both were made with double-sided carpet underfelt which was easily handled. Sufficient felt was used to produce a 115 mm (4½ in.) thick roll and this was protected by nyllex trellis material. Barbed wire was used as the centre support.

Good fly control was shown on these small properties but trials in more extensive areas were necessary. Also, further work was required to test the durability of these rubbers. Suspicion was placed on the durability of the trellis material.

Thus a trial was conducted from March 1974 to April 1976 on Mr A. Knuth's property 'Virginia Park' in the Charters Towers area. This property is in a belt of slightly undulating, open forest country. Fifteen back rubbers were erected in one bullock and four breeder paddocks, stocked at one beast to 7 to 8 hectares.

On some rubbers, wire netting was tested as a substitute for the trellis material. The effect of horns on both was disastrous, and they were abandoned in favour of heavy gauge prawning net.

Throughout the trial, other changes were made. The most important of these was the change from barbed wire to  $\frac{3}{16}$  in. chain as the centre support to suspend the rubber. Barbed wire stretched and put too much strain on the prawn net. Also, the sharp barbs tended to break up the felt. The chain together with the net held the shape of the rubber, thus extending its life.

While good fly control can be obtained in intensive areas, control is not entirely satisfactory in extensive areas. On 'Virginia Park' it was difficult to measure the degree of control but perhaps 70% control on 80% of cattle was a realistic result. Wet season conditions tend to scatter groups of cattle in large paddocks. Cattle do not use rubbers during heavy

wet periods. But at least there was a noticeable improvement in fly control when rubbers were used. At least this would be sufficient incentive to use rubbers on bullocks during their last year prior to slaughter. Mr Knuth claimed that bullock weights were higher when using rubbers.

On 'Virginia Park' the net lasted for 18 months on rubbers with continual use providing sufficient repairs were done. In many cases, the net lasted for 12 months with limited repairs. The final design of rubber was acceptable in terms of durability and method of manufacture.

While conducting the 'Virginia Park' trials, supportive observations of rubber use were made on the following properties:

'Salisbury Plains', Bowen. Owner—C. Barrett.

'Burnfoot', Dalta, Bowen. Owner—D. Pott.

A Townsville property. Manager—E. Tuckett.

'Burnside', Toobanna, Ingham. Owners—Reid Brothers.

Generally, good fly control was achieved on these coastal properties. The prawn net lasted from 6 to 12 months. Stocking rates were high.

## How to make a rubber

### The rubber

The most serviceable rubber is 3 metres (10 feet) long, made of carpet underfelt rolled around  $\frac{3}{16}$  in. chain. Fifty-seven gauge prawn net is laced tightly around the felt roll for the felt's protection. Swivels are attached to each end of the chain.

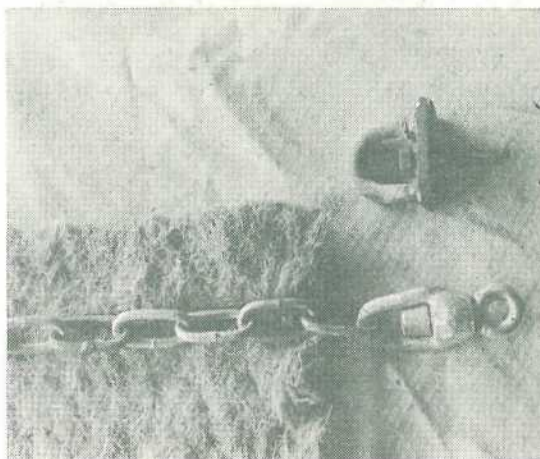

Plate 1.

### Materials required

- Prawn net ('cod end') 100 x 10 squares (380/57 ply— $1\frac{3}{4}$  in. mesh) (a suggested better product is Amikan net 400/600 ply— $1\frac{3}{4}$  in. mesh. This costs 67c more per rubber.)
- Nylon cord (8 ply—VB—3 mm) If this product is not available, polyethylene twine 400/48 ply can be purchased.
- 2 x  $\frac{1}{4}$  in. or  $\frac{5}{16}$  in. swivels or home-made type.
- 3.05 metres of  $\frac{3}{16}$  in. chain.
- 3.05 x 1.22 metres of double-sided carpet underfelt. This product varies by different thicknesses. Purchase the thickest felt.
- Plain wire or chain for suspending the rubber. Plain wire is required to suspend the molasses tin.

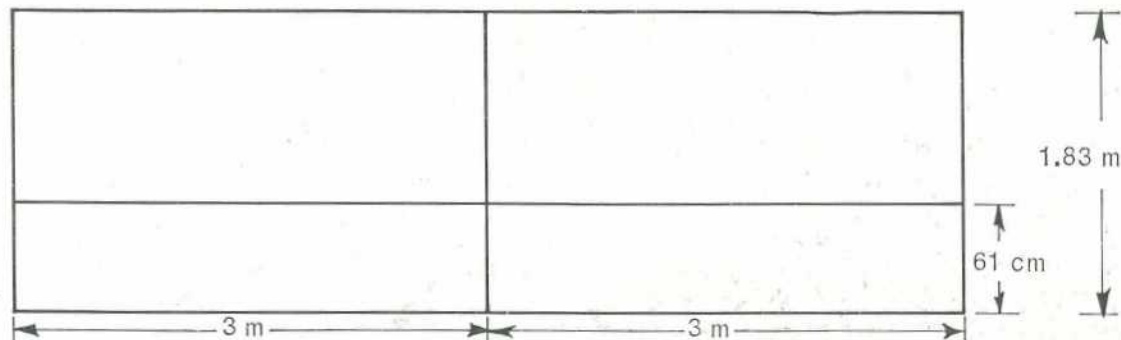
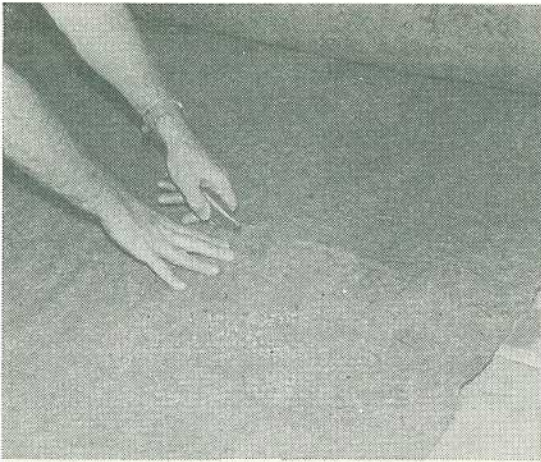

Diagram A.



### Tools required

- 1 nylon net needle.
- Bag needle.
- 1 sharp cutting knife.
- Bolt cutters if required.
- Welder if required.

*Upper left. Plate 2.*

*Lower left. Plate 3.*

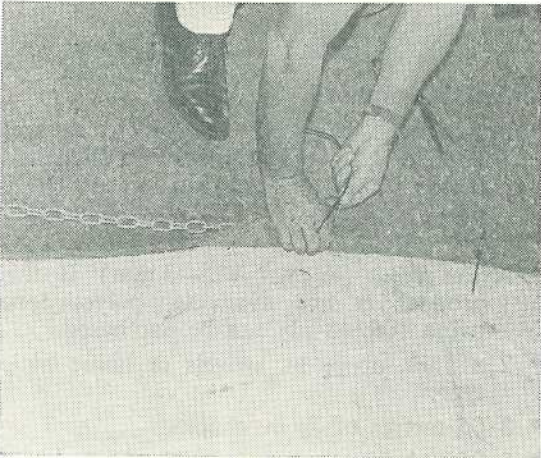

*Above. Plate 4.*

*Below. Plate 5.*

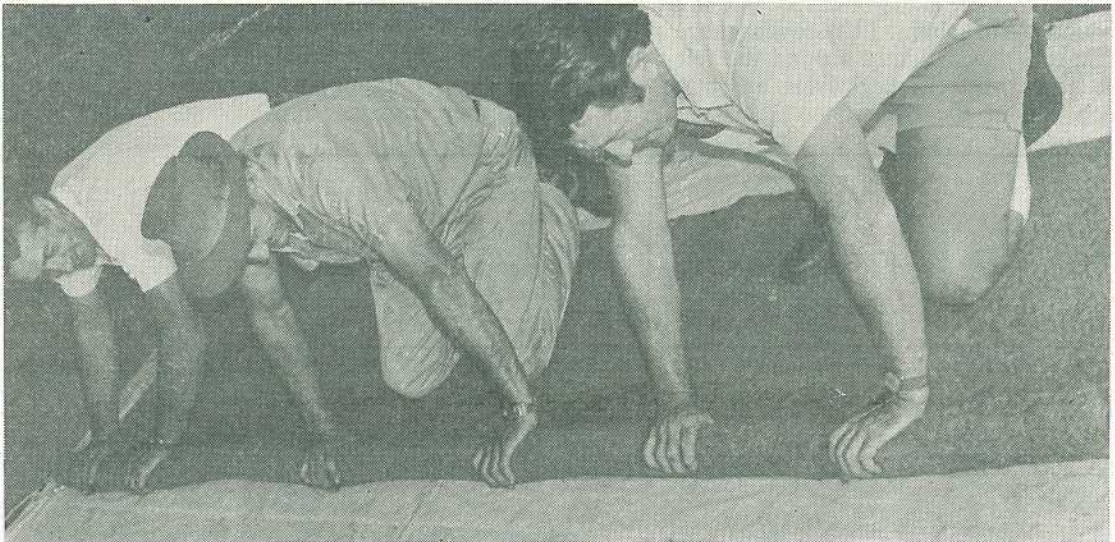
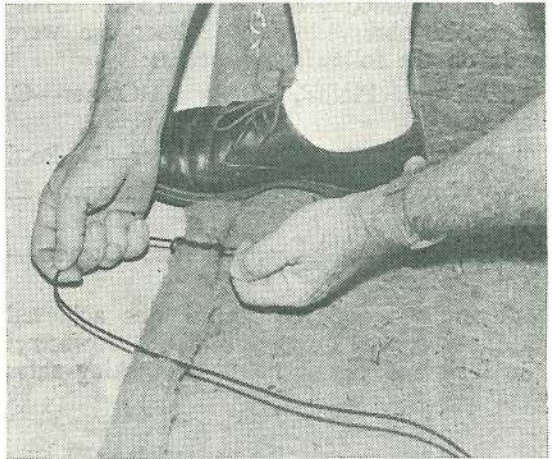

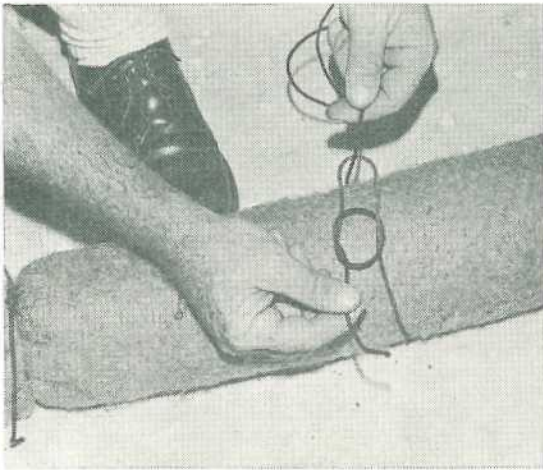
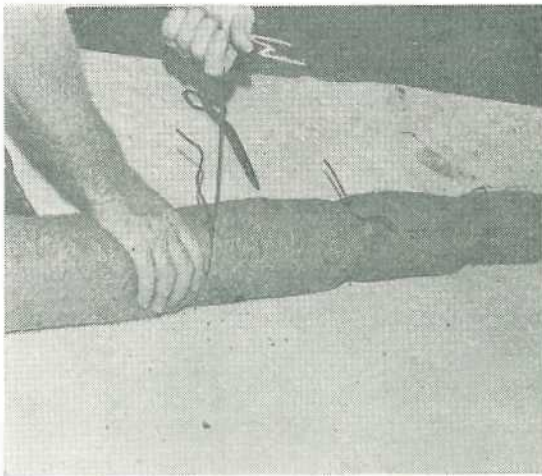

Plate 6.



Above. Plate 7.

Below. Diagram B.

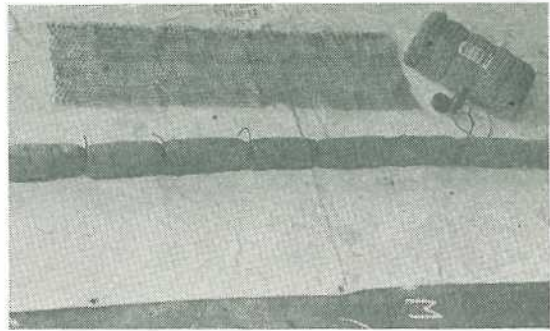
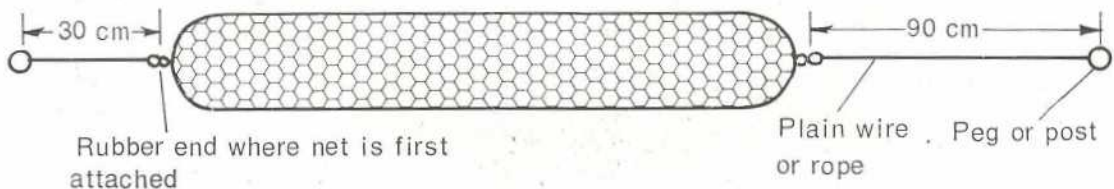

Plate 8.

### Centre support

Refer to plate 1. Fit a commercial or home-made swivel to each end of the chain. The swivel enables the operator to turn the rubber when repairs are needed. Also, when cattle use them, the swivels allow the rubber to roll slightly. However, Reid Brothers do not use swivels but simply add 15 cm of chain to either end.

### Rolling the felt

The underfelt is 1.83 metres wide. Six metres of felt is sufficient for three rubbers if cut according to diagram A.

Cut the felt with a sharp knife by using a board under the felt. Refer to plate 2. An area of felt 3 metres x 1.22 metres is sufficient for one rubber. Place the prepared chain and swivels on the 3 metre edge, so that the swivels are evenly jutting over the felt ends. At 300 mm intervals, fold the felt edge around the chain and tie tightly with the VB cord. Refer to plate 3 and 4. A bag needle is used to put the cord through the felt.

Roll the felt around the chain as tightly as possible. Refer to plate 5. Kneel on the unrolled portion of the felt while rolling. The roll can be tightened by pressing the roll away from the body but rolling towards the body. At least 3 people are needed to obtain the required firmness.

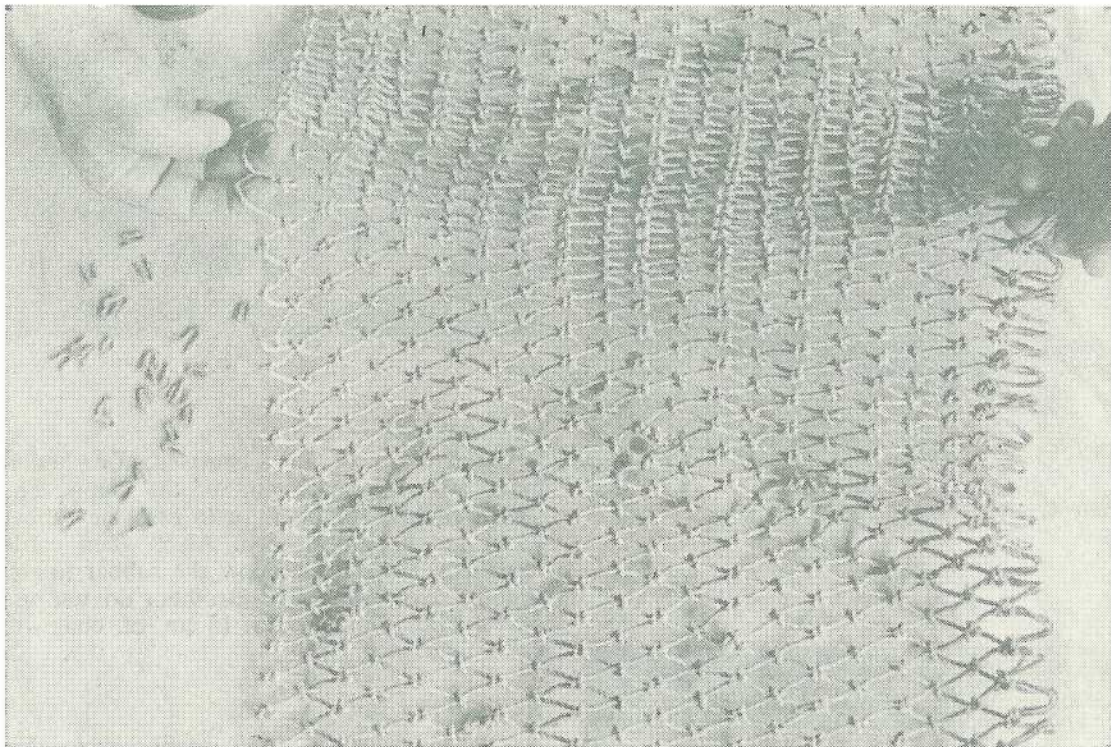

*Above. Plate 9.*

*Below. Plate 10.*

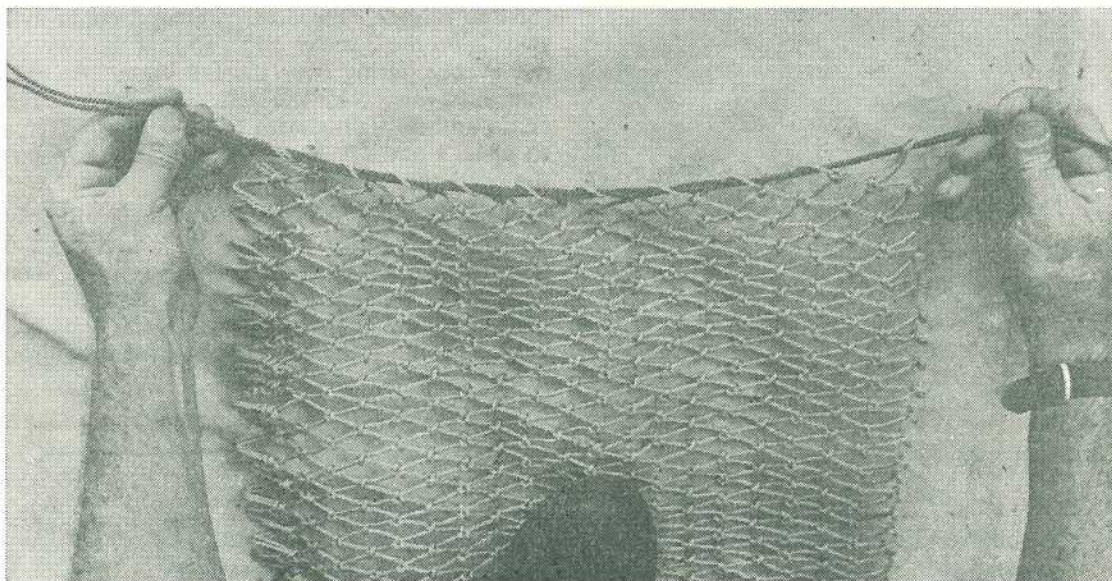

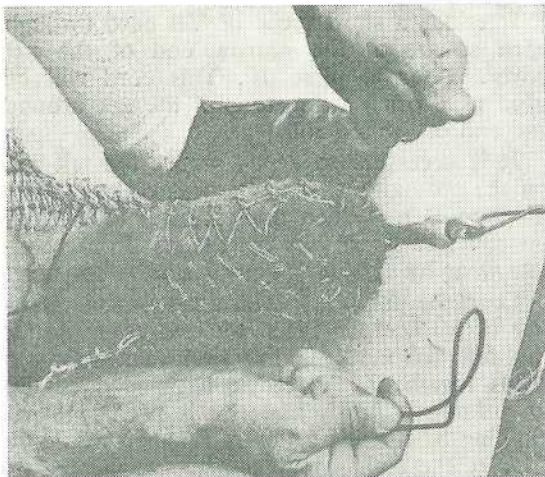

Plate 11.

To secure the roll, use a non-slipping knot to tie single ties of VB cord around the felt. Refer to plates 6 and 7. Finish off the knot with a half hitch. Each tie is approximately 300 mm apart with the end ties being 20 mm from the ends of the roll.

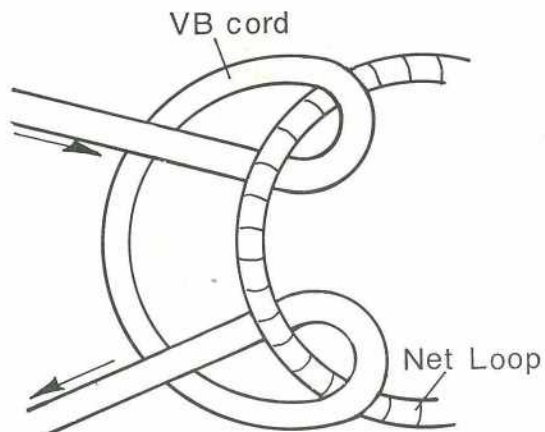

Diagram C (see plate 13).

### Attaching the net cover

Each cod end (100 x 100 squares) is sufficient for nine rubbers and the net required for each rubber measures 100 x 10 squares. Refer to plate 8. Count 10 squares and cut across the net after the tenth square. Remove the short cut ends so that each cover is boarded by loops for lacing purposes. Refer to plate 9.

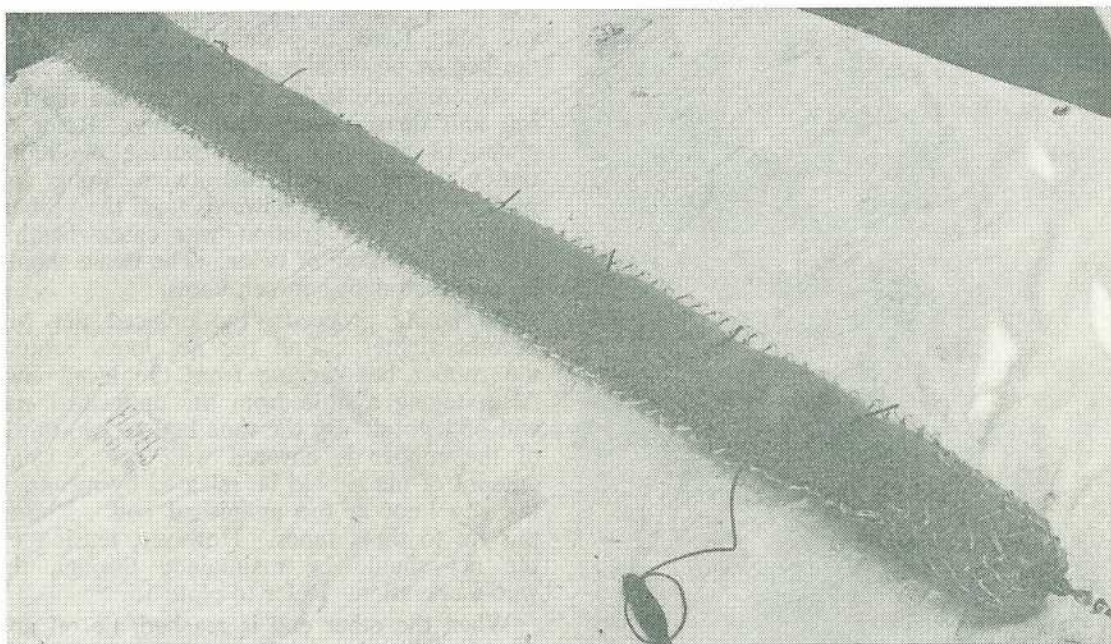
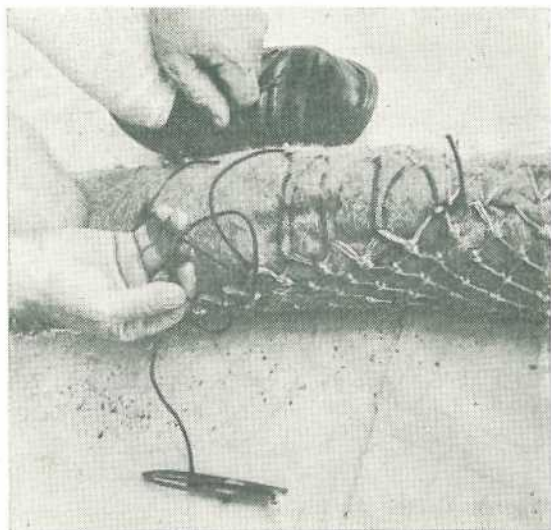

Plate 12.



Above. Plate 13.

Below. Plate 14.



Interlace a short piece of VB cord through each square at the narrow end of the net cover. Refer to plate 10. This cord will be used as a draw string to pull the net around the end of the felt roll.

It is necessary to firmly secure the felt roll on the ground between two pegs or posts (see diagram B.). When applying net to the felt on concrete floors, protect the net from needless wear by spreading canvas on the concrete.

Load the net needle with a reasonable quantity of VB cord. Place the net cover under the felt roll and tie the first two opposing loops together. Polyethylene twine does slip in a knot. If this material is used, prevent slipping by making an extra knot on the loose ends of the main knot.

Lace four opposing loops along the rubber and tie using the knot as shown in diagram C. Take up the slack twine and before tightening the knot, stretch this net section along the rubber.

While keeping knee pressure on the rubber, stretch the net around the end of the rubber. Pull the draw string tightly so that the ends of the net are pulled around the swivel and tie off. Refer to plate 11.

Stretch the remaining net along the felt roll to extend 60 cm or more past the other roll end. Refer to plate 12. Tie this net to the peg or post, using a slip knot.

Recommence lacing the net around the felt roll and tie off every four loops. Refer to plates 13 and 14. When pulling the loops tightly together, pull the twine along the rubber. Do not pull upwards from the rubber, otherwise excess friction will cause heating and thus breaking of twine. The twine should be pulled straight between knots.

As lacing proceeds, the unlaced net will become tighter. Pull the net loops around the rubber but tugging from the laced end. Also, tugging a little from the unfinished end will be helpful. By the time half to two-thirds of the rubber is covered with net, a small amount of net should be released by means of the slip knot at the unfinished end. Repeat this up to three times. However, tension on the net should be maintained through the whole operation. Refer to plate 15.

When the other end is reached, tie off and then insert a draw string of VB cord around the rubber but through the net squares. Pull



the net tightly around the rubber end to the swivel. Cut off the remaining net 2 to 3 squares away from the draw string. The loose net can be tied back to make a neat finish. Refer to plate 16.

It is important that the net is laced firmly around the felt roll. Increased firmness results in more net being left over after lacing. A few single ties around the finished rubber will increase durability.

## How to use rubbers

### Rubber distribution

One rubber is sufficient for 100 to 150 cattle but this would depend on the size of the paddock and the number of watering points. Watering points which are usually camping areas are the best rubber positions. In large paddocks, rubbers may have to be positioned at all main watering points. This may result in a distribution rate of one rubber to 100 cattle.

A rubber can be located a short distance from a watering point providing it is positioned on a main cattle pad. Some changes may be necessary to find the best spot.

In wet, tropical areas, a mound of gravel may have to be formed before erecting a rubber. Thus the formation of a bog will be prevented. In some situations, shelter sheds may be available.

### Erection of rubbers

The rubber is suspended above ground at a height whereby the cattle can rub the uppermost parts of their bodies. Trees or posts as supports are used for this purpose. Many ways can be chosen to attach the rubber ends to the supports but a simple method of using a railway line dog spike or bolt is quickest.

Chain or lengths of plain wire can be used to attach the swivel to the tree support. If the latter is used, wind the wire loosely around the spike. If the wire is tight on the spike, it will break at the twist due to constant moving of the rubber. Chain is preferred to prevent a rubber end from collapsing to the ground. Cattle will still continue to use a rubber in this collapsed position with one end still attached to a tree. However, this action increases damage to the net.

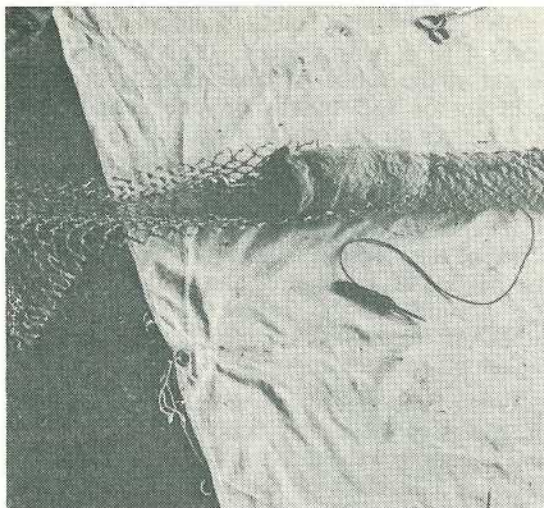

Plate 15.

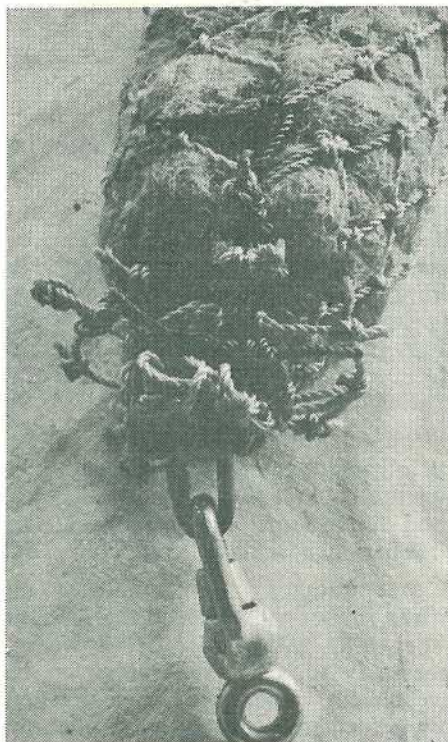

Plate 16.

To suspend the rubber, choose two supports 4 to 5 metres apart. For breeders, the height of the rubber is determined by marking a height of 1.5 metres on one support and 1.2 metres on the other. A spike is hammered into these positions. The rubber is suspended firmly between the two spikes.

If the rubber is too high for weaners, slacken the tension slightly. For bullocks, use heights of 1.5 metres and 1.2 metres from the ground to the respective ends of the rubber, thus making the points of attachment higher on the tree supports.

When rubbers are first introduced, a supply of molasses near the rubber attracts cattle and encourages them to use the rubber quickly. Hang a 5 litre tin of molasses in close proximity to one end of the rubber. The tin must be hung at a height above ground to prevent damage by cattle. It must have an air tight screw lid and a small hole (1.5 mm) in the bottom. The sun's heat during the day will counteract the vacuum in the tin and release a small amount of molasses on to a large, flat rock provided for the purposes.

### Charging of rubbers

While Ethion has been mainly used in back rubber trials, other chemicals may also be suitable except methionychlor.

Mix 1 part of Ethion to 60 parts of sump oil. This will ensure that there is 1% of Ethion active ingredient in the mixture. A 20 litre drum is a suitable container to transport the mixture around the property (mix 333 millilitres of Ethion with 20 litres of sump oil). Care must be taken to properly mix the chemical throughout the oil.

The first charging of a new rubber requires 11 litres of oil mixture which is poured on in strips along the rubber. Use a calibrated jug with a good lip. Some cattlemen prefer to soak the rubber in a shallow trough.

In the first instance, the amount of oil poured on the rubber must exceed the amount used by the cattle within the first 2 weeks. This is necessary to allow the rubber to be thoroughly soaked. Therefore, after the first week apply a further 2 to 4 litres of mixture. The quantity is gauged by the amount of oil retained in the felt roll.

Subsequently, only 2 litres of mixture should be necessary every 3 weeks during the 6 months of the fly season.

### Maintenance

The fly season is from November to April. From the 'Virginia Park' trial results, it was estimated that if rubbers are stored between these periods the net should last for three fly seasons providing repairs are regularly carried out. After such time, the net is renewed. Also, 20% of felt rolls may have to be renewed or repaired especially if the repairs to the net are poor.

On intensive properties, the net cover will probably need to be renewed after each fly season because of greater use of rubbers.

The durability of rubbers in western open downs country may be suspect. As there are no trees for cattle to rub on, rubbers and fence posts receive extra use which greatly reduces their life.

In all situations, regular inspections and necessary repairs are important to increase the life of the rubber. Broken net should be repaired by VB cord as early as possible to prevent felt damage. Serious damage can occur if horns are caught in the net when it is new. However, this would be unusual if the rubber is made properly with net firmly laced around the felt roll.

Blockage may occur to the hole in the bottom of the hanging molasses tin. Poke a piece of thin wire through the hole to release the molasses.

### Costs

The materials needed to make one rubber cost about \$18 using commercial swivels and \$16 with home-made swivels.

The cost of using rubbers on 'Virginia Park' was 99 cents per head in the first year. This cost comprises 55 cents per head to make and set them up and 44 cents per head to run them. For each year after that the cost is 44 cents per year. These costs include interest, labour, depreciation and vehicle operating expenses. The running costs assume 6 months of fly season and 6 months storage.

In intensive areas, the cost would be lower because the distance between rubbers is far less.

These costs could be compared with the higher cost of overspraying with methoxychlor. It would cost 54 cents per head per muster to overspray. Even three treatments per fly season would not control buffalo flies but simply give cattle relief for 1 week per treatment.

### **General comments**

Back rubbers are the cheapest form of fly control we have. Providing the rubber is designed and made properly, it will effectively control flies and save labour. But apart from the maintenance problem, they naturally are not without other problems. However, maintenance is significantly reduced with this design of rubber.

### **Rubber acceptance**

Weaners and bullocks quickly learn to use rubbers, but breeders are hesitant. This may be due to them being preoccupied with their calves. It takes some time for breeders to use them although it is seen that some cows do take an immediate liking to play with them. Perhaps the training of breeders from weaning age could improve this problem.

### **Climatic disadvantage**

Flooded water courses and boggy ground during the wet season restrict the servicing of rubbers by vehicle. Anticipating these conditions, a supply of chemical and oil mixture could be left beside each rubber. Inspections then could be made on horseback or motor-bike.

### **Storage of rubbers**

Due to the cost of the rubbers and the effort put into making them, it is worthwhile to store them between fly seasons to increase their life. To make the job of removing rubbers easier, use hooks to attach the rubber to the dog spike on the tree.

### **Where materials can be purchased**

Inquiries can be made through the Department of Primary Industries at Townsville—phone 71 4145.

### **Acknowledgement**

I extend my thanks to all those cattlemen who have been associated with trial work and supportive observations. In particular, I thank Mr A. Knuth for his co-operation and supply of equipment during the 2 years 6 months of trial work.

---

## **Agricultural Bank loan interest reduction approved**

The Minister for Primary Industries, Mr V. B. Sullivan, announced approval for a reduction in the interest rate charged on Agricultural Bank Loans from 10.325% to 9.325%.

He said the 1% reduction would apply to all advances made, and all moneys owing and unpaid, from the first day of May, 1978.

Mr. Sullivan added that State Cabinet had agreed to this variation in the interest rate on April 10.

# Pastures for the Gympie district

by B. G. COOK, Agriculture Branch.

## Establishment and management

### Seedbed preparation

THE aim in seedbed preparation is to provide a suitable medium for seedling emergence and survival.

This is best achieved in a clean, shallow, fine, firm seedbed. The precise sequence of tillage operations necessary to obtain this depends on the soil type, the soil moisture level and the cultural history of the land.

It is not always possible to obtain perfect seedbed conditions. The land may be too steep to plough, or unsuitable weather may prevent one or more of the tillage operations. In such situations, good establishment is still

possible, but increased seeding rates are necessary. Burning is a useful way of eliminating the bulk of native grass before commencing seedbed preparation or sowing with minimal preparation.

### When to plant

For tropical species, the best time to plant is November to January. February and March may also be suitable, but excessively wet conditions in these months can prevent vehicle movement on ploughed land.

For temperate species, mid March to May are the more successful planting months. Success may be achieved at other times, but adverse weather influences such as low early spring rainfall, early frosts or extremely low mid winter temperatures reduce the chances.

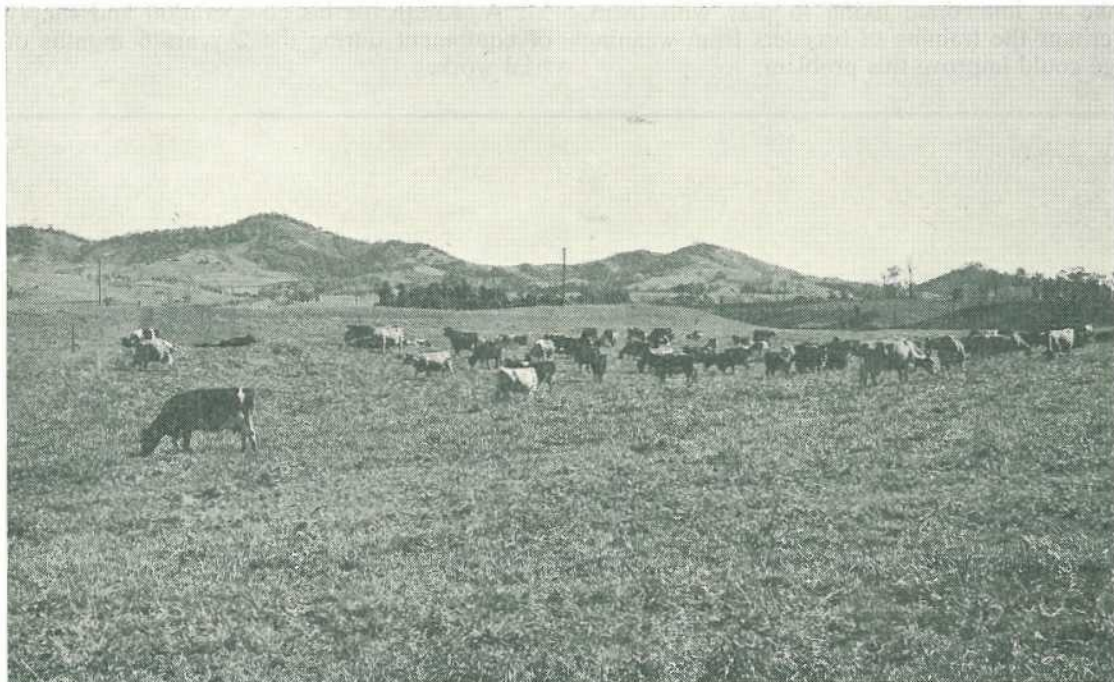

Dairy cows grazing nitrogen-fertilized ryegrass at Dagon.

# ... part 3

## Seed treatment

### (a) LEGUME INOCULATION

For legumes to fulfil their role as a nitrogen source, it is necessary for the legume seed to be inoculated with a suitable strain of rhizobium, the root nodule bacteria. Although many legumes will nodulate successfully on native rhizobium, it is advisable to use the correct commercial peat preparation. With some legumes (for example lotononis), it is essential.

Simple inoculation can be achieved using a water slurry or a dilute sticker technique. This is adequate if the seed is sown separately from the fertilizer. If the seed is to be mixed with fertilizer prior to planting, pelleting with lime (leucaena, lucerne, clover) or rock phosphate or bauxite (all tropical legumes except

leucaena) is necessary. Instructions are provided with the inoculum.

### (b) BEAN FLY TREATMENT

Siratro and phasey bean seedlings are subject to attack by bean fly, especially in plantings made later than December. Seed treatment with dieldrin or endrin at 2 gm active constituent per kilogram of seed gives effective control of this pest. To avoid adverse effects on the rhizobium, it is important that three rules be observed:

- The seed must be allowed to dry thoroughly after treatment with insecticide and prior to pelleting.
- A peat inoculant should be used.
- The inoculant should be applied after the insecticide treatment.



Young beef cattle grazing improved pasture near Kandanga.

### (c) MOLYBDENUM TREATMENT

Molybdenum trioxide may be incorporated into the pelleting material of the seed pellet as an alternative to mixing this element with the establishment fertilizer. Sodium molybdate should not be used for this purpose.

### Planting

Seed may be broadcast or placed, depending on the machinery available, the nature of the terrain, and individual preferences based on economics and experience. However, regardless of the method adopted, two basic rules always apply:

- Seed should not be planted too deeply, otherwise emergence is reduced. Adequate seed coverage can often be obtained by broadcasting the seed and then traversing the ground with branches or inverted diamond harrows.
- The ground should be rolled immediately after sowing. Rolling forces closer contact between seed and soil particles and also reduces evaporation from the soil surface, thus enhancing germination and establishment. The tyre roller comprising a spindle and a number of old tyres is a useful implement for this purpose, although more sophisticated implements are available.

### Establishment fertilizer

There are very few soils in this district without inherent or induced (for example, old cultivations) nutrient deficiencies. Most are deficient in phosphorus, nitrogen and molybdenum. Some (soloths, lateritic podzolics and podzols) are also deficient in potassium, and others (prairie soils on andesite) in sulphur.

How do we determine requirements? If the area has been under native or naturalized pasture, refer to the 'Planting Recommendations' table. If the intended area has a history of cultivation, it is best to utilize one of the soil testing services available. Interpretation of results should be made in consultation with a D.P.I. officer or fertilizer

company agronomist familiar with the area and competent in this field.

There are several factors that affect establishment fertilizer recommendations:

- **NITROGEN**—In general, nitrogenous fertilizers should not be applied with mixed grass/legume plantings, but can be extremely beneficial to pure grass plantings. However, in the former case with rapid seedbed preparation, a basal application of 20 to 30 kg of nitrogen per hectare ensures better grass establishment. Higher amounts can lead to early grass dominance, with a consequent reduction in legume stand.
- **MOLYBDENUM**—Molybdenum is an essential element for nitrogen fixation in the legume nodule. Deficiency is widespread in the district. Legumes vary from species to species in their responsiveness to molybdenum. Greenleaf desmodium and glycine need about 200 g of molybdenum per hectare every 3 years. Siratro may need up to 200 g of molybdenum per hectare. However, 100 g per hectare every 3 to 4 years is generally adequate. Lotononis and stylo are not very responsive to applied molybdenum, but an application of 100 g per hectare every 4 to 5 years ensures sufficiency.

Molybdenum can be supplied in the form of molybdenized superphosphate or incorporated in the pelleting material in the legume seed pellet. Mo 12 superphosphate at 500 kg per hectare or Mo 24 superphosphate at 250 kg per hectare delivers 100 g of molybdenum per hectare.

- **LIME**—Tropical legumes prefer a pH above 5.0 and temperate legumes a pH above 5.5. Responses to lime can be expected with pH values below these. Precise recommendations vary with the soil type and the pH shift required, but, as a general rule, 2 to 3 tonnes of lime per hectare will raise the pH by one unit.
- **TIME OF APPLICATION**—When lime is necessary this should be thoroughly incorporated into the soil well before planting, particularly when used at high rates.



*Harvesting seed of Safari clover, Boonooroo.*

Other establishment fertilizers can also be applied during seedbed preparation. It is sometimes more convenient, however, to apply phosphorus, potash, trace elements and nitrogen at the same time as the seed. For broadcast sowings, the seed and such fertilizers as single superphosphate or molybdenized superphosphate, and some mixtures, may be mixed and applied together, provided the legume seed is pelleted. There are some mixtures, however, which are not safe to mix with the seed at high rates. Your local advisory officer or fertilizer supplier can give specific advice on these.

### **Maintenance fertilizer**

The basal fertilizer dressing mostly serves to provide an initially high nutrient level in the soil for the developing seedling. However, it rarely raises the soil nutrient level to the optimum required. Subsequent fertilizer applications aim at attaining this optimum as quickly as possible and maintaining it.

In legume-based pastures, the nitrogen aspect is attended to by the legume, provided

no other deficiency is present. If phosphate levels are maintained using superphosphate (9.2% phosphorus, 10% sulphur), sulphur deficiency will not develop. Molybdenum deficiency is easily overcome by substituting molybdenized superphosphate every 3 to 4 years. This then leaves phosphorus and potassium maintenance as the prime considerations.

There are four bases for determining type and quantity of maintenance fertilizer:

- Tradition, whereby the landholder applies fertilizer at a given rate determined by research findings, experience or economic limitations.
- Plant symptoms, whereby a particular set of visual symptoms indicates a need for a particular nutrient.
- Plant analysis, where deficiency or otherwise as defined by plant levels as related to predetermined critical levels.
- Soil analysis, where once again levels are related to critical levels.

None of these in itself is adequate. However, when considered together, a suitable maintenance programme can be arranged. The general order of maintenance dressings where indicated are superphosphate at 100 to 250 kg per hectare and muriate of potash at 50 to 100 kg per hectare.

### Irrigation management

Irrigation is one of several practices available to the farmer to help maintain a continuous supply of high quality feed throughout the year. It is largely restricted to the flatter areas adjacent to the various watercourses, although some areas have been established on steeper, shallower land away from the streams.

Some basic principles affecting irrigation decision making are:

- Choice of soils—virtually any well-drained soil is suitable.
- Water supply—sufficient water of good quality for the envisaged project is necessary. To ascertain adequacy and suitability of the source, it is best to seek Department of Primary Industries or Irrigation and Water Supply Commission advice.
- Frequency and amount of irrigation—in very general terms, 50 mm of water (rainfall and irrigation) is required every 14 to 18 days in autumn, spring and winter and about every 10 days in summer. In extremely evaporative summer conditions, this interval may need to be reduced to 7 days. These values vary with soil texture, soil depth, humidity, wind conditions, temperature etc. The main requirement is that water should never be a limiting factor to plant growth.
- Fertilizer—desirable soil nutrient levels are the same under irrigation as in a dryland situation. However, the quantities of fertilizer required to maintain these levels are higher. There is a constant likelihood of potassium deficiency developing in those areas where recycling is minimal. With water non-limiting, more reliable and greater amounts of feed can be produced from applying fertilizer nitrogen to a pure grass sward than from a grass-legume pasture. The two grasses most commonly used for this purpose are kikuyu and ryegrass.

### Grazing management

The aim of grazing management is to provide and maintain a stable, productive system. To this end, we must present the animal with a good bulk of leafy forage, but retain sufficient leaf material on the pasture to provide for reasonable regrowth. In grass/legume pastures it is most important to maintain legume vigour, since the legume is the source of nitrogen for the grass. Grazing management must therefore favour the legume.

Some legumes tolerate and even prefer high stocking pressures. These are the prostrate group such as white clover, lotononis, Oxley stylo and Safari clover. The more erect legumes such as Cook or Endeavour stylo and the trailing, twining group such as axillaris, glycine, Greenleaf desmodium and Siratro, are susceptible to heavy grazing. If these are overgrazed, it is necessary to provide for a destocked recovery period.

There are two basic pasture management procedures—rotational and continuous. Rotational grazing is essential for persistence of lucerne and ensures higher productivity of irrigated pastures. It also assists in irrigation management, since the irrigation cycle is usually the same as the grazing cycle. The continuous system makes for ease of stock management with larger areas of improved pasture. However, under a continuous grazing system stocked to near capacity, permanent damage through overgrazing can be done in stress periods, particularly to susceptible legumes. Damage can be minimized if an area of grass-plus-nitrogen is available to lessen the pressure on the legume-based pastures.

### Conclusion

Pasture is still the cheapest source of animal feed. What is the value of improved pasture? The precise economics of pasture development must be evaluated on an individual property basis. However, its value in terms of improved animal production and improved carrying capacity has been well substantiated experimentally. In the dairying situation, increases of 50% butterfat per cow and twofold stocking rate increases are typical. In the beef situation, up to threefold increases in weight gain per animal and in stocking rate have been recorded.



The pasture programme must be planned carefully. Costs are too high to permit non-strategic development. The aim should be to provide as near as possible a continuous supply of high quality forage. This is not attainable from any one pasture mixture; however, by taking advantage of the different production patterns of a number of species, a fair continuity of feed can be provided.

An extreme case is that of H1 ryegrass and Nandi setaria. While the setaria commences growth in spring, peaks in summer, declines in autumn and is dormant in winter, the ryegrass commences in autumn, maintains fair growth in winter, peaks in spring and is dormant in summer. With careful selection of relative areas planted, these two species can complement one another, except for a slight autumn deficit. This could well be filled by kikuyu or Narok setaria, which have good autumn growth.

Once the pasture is established, the grazing management imposed can determine the success or otherwise of the venture. This has a strong effect on the productivity of the pasture and, in the case of tropical pastures, on their persistence. The most common cause of pasture decline in the area is over-grazing, although poor fertilizer maintenance frequently contributes.

### Further reading

Brands, L. E., and Cook, B. G. (1976). Whittet kikuyu in the Gympie district. *Queensland Agricultural Journal* 102: 429.

Bryan, W. W. (1973). A review of research findings concerned with pastoral development on the wallum of south-eastern Queensland. *Tropical Grasslands* 7:175.

Coaldrake, J. E. (1961). The Ecosystem of the coastal lowlands ('Wallum') of Southern Queensland. C.S.I.R.O. Bulletin No. 283.

Isbell, R. F., Thompson, C. H., Hubble, G. D., Beckmann, G. G., and Paton, T. R. (1967). *Atlas of Australian Soils* Sheet 4.

Kerridge, P. C., Cook, B. G., and Everett, M. C. (1973). Application of molybdenum trioxide in the seed pellet for sub-tropical pasture legumes. *Tropical Grasslands* 7:229.

O'Grady, R., and Cassidy, G. J. (1976). An irrigated pasture system based on annual ryegrass sowings. *Queensland Agricultural Journal* 102:3.

Pasture Improvements in the Gympie District, S.-E. Queensland field meeting—April, 1965. The Tropical Grassland Society of Australia Proceedings No. 6.

Rees, M. C., Minson, D. J., and Kerr, J. D. (1972). Relation of dairy productivity to feed supply in the Gympie district of south-eastern Queensland. *Australian Journal of Experimental Agriculture and Animal Husbandry* 12:553.

Stillman, S. L., and Ostrowski, H. (1976). Temperate pastures for dairying in south-east Queensland. *Queensland Agricultural Journal* Vol. 102 No. 6.

---

## CHANGING YOUR ADDRESS?

Please let us know as soon as possible if you intend changing your address.

Because the addressed wrappers and journals are printed separately, changes cannot take effect until the next batch of wrappers is printed.

This means that, in some cases, subscribers will receive the next issue at their old address.

If possible, two months' notice should be given to ensure your Journal is sent to the correct address.

# The lawn armyworm

## . . . a serious rural and urban pest

by R. H. BROADLEY, Entomology Branch.

THE lawn armyworm (*Spodoptera mauritia*) is a well known agricultural pest.

It is also common in urban areas where it may cause considerable damage to lawns, bowling greens, golf courses, lawn tennis courts and to commercial turf production. This pest is also found overseas and causes significant damage to crops such as rice, maize, sugar, wheat and barley.

### Distribution

The lawn armyworm is widely distributed in Queensland. Although it has been recorded as far west as Emerald, it is more commonly found in coastal and sub-coastal regions from north Queensland to the southern border. This distribution, however, may merely reflect

its impact in major centres of agricultural production, rather than illustrate the real geographic limits of the pest.

The species has also been recorded from the African mainland, Madagascar, parts of the Middle East, Pakistan, India, South-east Asia (including the Philippines, Indonesia and Papua-New Guinea), Hawaii and numerous Pacific islands.

### Plant hosts

The plant hosts of the lawn armyworm in Australia and overseas, shown in table 1, demonstrate that it is essentially a grass-feeding species, although it may also develop on certain sedges. The most important crop hosts are rice, sugar-cane and maize.

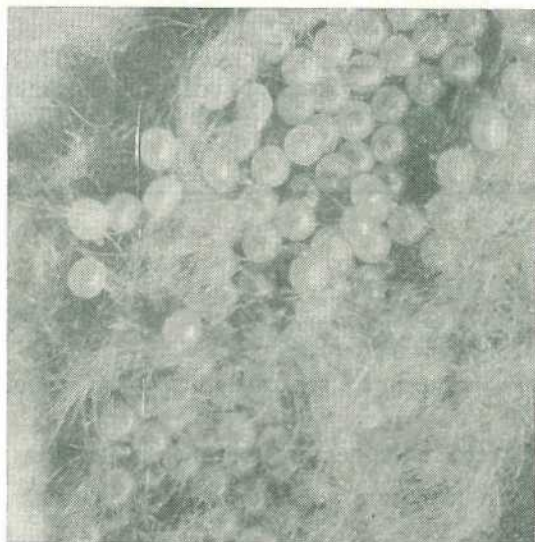

A cluster of lawn armyworm eggs. Note the hair-like scales.

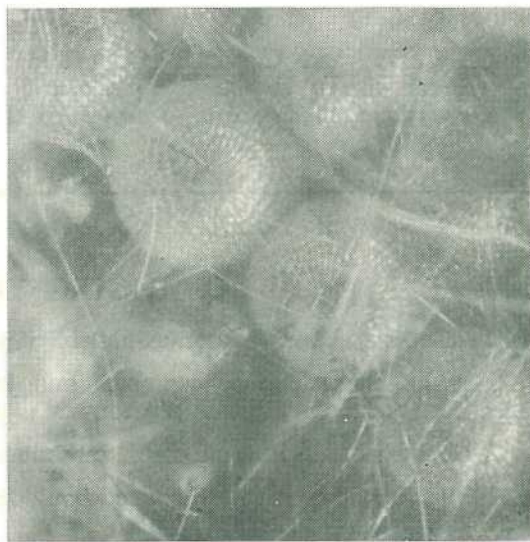

A close-up view of lawn armyworm eggs.

TABLE 1

## HOST PLANTS OF THE LAWN ARMYWORM

Plant type	Common name	Scientific name
Grasses	Rice	<i>Oryza sativa</i>
	Maize	<i>Zea mays</i>
	Sugar-cane	<i>Saccharum officinarum</i>
	Bermuda grass	<i>Cynodon dactylon</i>
	Orchard grass	<i>Agropyron repens</i>
	Kikuyu	<i>Pennisetum clandestinum</i>
	Ragi	<i>Eleusine coracana</i>
	Pangola	<i>Digitaria decumbens</i>
		<i>Isachne globosa</i>
	Paspalum	<i>Paspalum conjugatum</i>
	Paspalum	<i>Paspalum scrobiculatum</i>
		<i>Pennisetum typhoideum</i>
	Wheat	<i>Triticum aestivum</i>
Barley	<i>Hordeum vulgare</i>	
	<i>Chaetochloa verticillata</i>	
Sedges	Sedge	<i>Fimbristylis acuminata</i>
	McCoy grass	<i>Cyperus gracilis</i>
	Nut grass	<i>Cyperus rotundus</i>
	Kyllingia	<i>Cyperus kyllingia</i>

In addition to the hosts listed in table 1, feeding studies conducted in Toowoomba show that at least another nine common grass species are suitable for larval growth, the most important of these being oats (*Avena sativa*), para grass (*Brachiaria mutica*), and green panic (*Panicum maximum*).

### Armyworm life stages

The lawn armyworm passes through four distinct development stages. These are the egg, larval, pupal and adult stages.

- **ADULT.** The adult lawn armyworm is a greyish-brown moth, with a wing span of approximately 35 to 40 mm. Males have variable white and dark markings on the forewings, but these are more subdued in the female. The hindwings are a pale, shining white colour. When at rest, the wings of the insect are invariably folded in an inverted V over the abdomen.
- **EGG.** Mated female moths deposit eggs in clusters and cover them with buff-coloured, hair-like scales from the tip of the abdomen. This gives the egg mass a 'furry' appearance.

Individual eggs, approximately 0.5 mm in diameter, are shaped like a flattened globe and are light brown in colour. Up to seven

layers of eggs have been recorded in a single egg mass, but three to six layers are common. Although light tan when newly laid, egg colour deepens during embryo development. Shortly before hatching, an outline of the body and dark head capsule of the developing larva can be seen through the semi-transparent egg shell. Infertile eggs become metallic green with a pink spot at the apex.

- **LARVA.** During development, the larvae generally pass through seven growth stages or instars, each being larger than the preceding one. A growth stage is characterized by a moulting or shedding of the complete larval skin and head capsule.

Dark, spiky body hairs and a dark head capsule are the most obvious features of a newly-hatched larva. The slender, cream-coloured body attains a greenish hue after feeding commences.

Distinct changes in body colour occur during larval development. After the first moult, a number of thin, white longitudinal stripes appear along the top and sides of the body, and the head capsules of the second and later instars are brownish rather than black.

After further moults, two variable reddish marks, one on each side of the body, develop posteriorly. These may expand into pink or purplish bands and the larvae may possess an overall pinkish tinge.

Towards maturity, characteristic black triangular marks become more prominent. In the final instar, these dark triangles are a dominant feature of larval colouration, being superimposed on a background of brownish dorsal and lateral bands.

Fully grown larvae up to 45 mm in length and 7 mm in width have an inflated, sausage-like appearance with body width being much greater than that of the head capsule. They possess three pairs of walking legs on the thorax and five pairs of fleshy 'pro-legs' on the abdomen.

- **PUPA.** Pupae are formed in specially constructed chambers in the soil and constitute the transition from the larvae to the adult moths. They are deep brown in colour and measure about 15 mm in length and 5 mm in width.

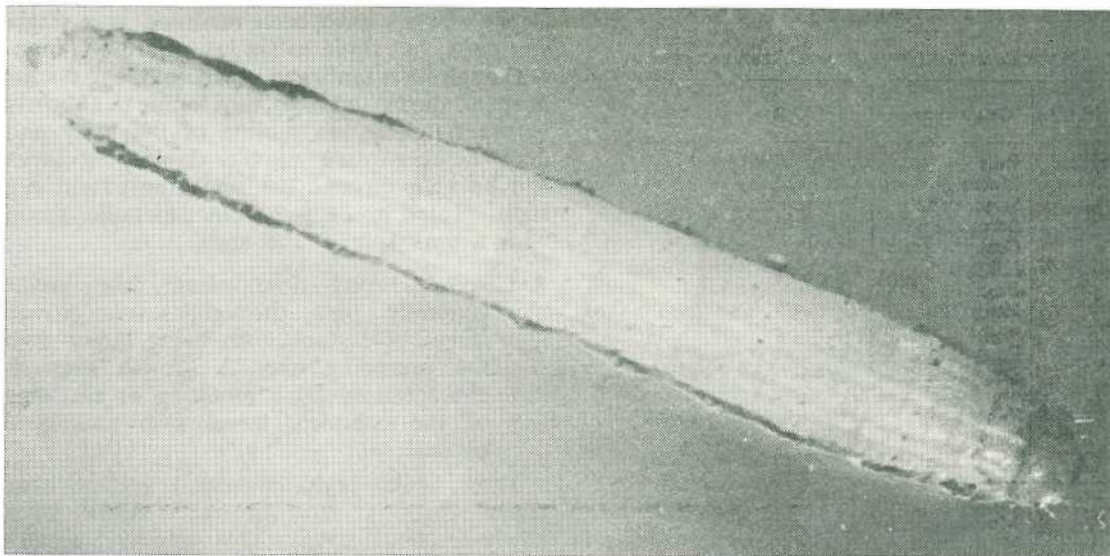

ABOVE. A young lawn armyworm larva.

BELOW. A mature larva. Note the two rows of 'triangles' along the back of the larva.

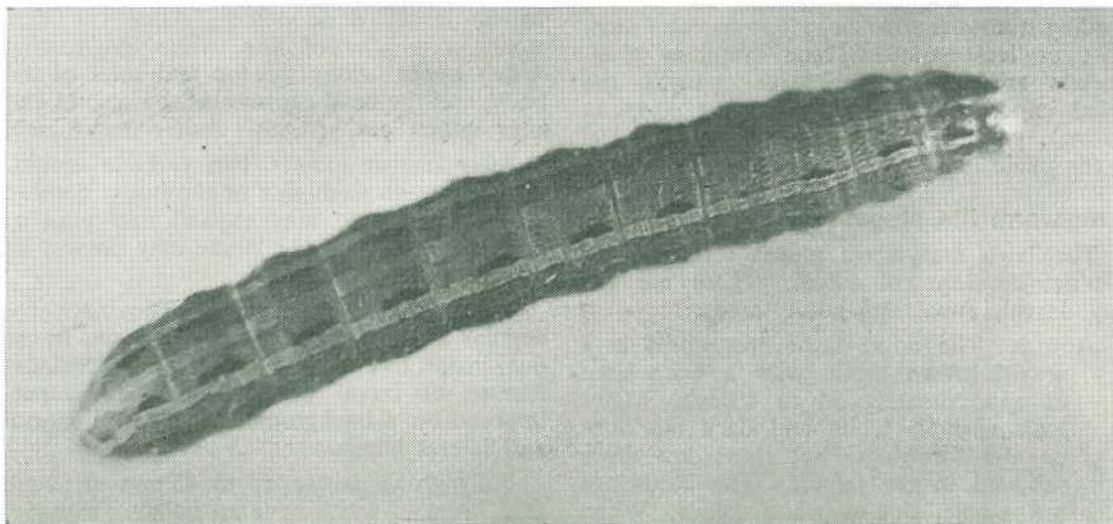

### Biology

After emerging from the pupal stage, moths tunnel to the soil surface. They mate from the first night after emergence and egg-laying may commence 2 nights later. Most eggs are deposited between dusk and midnight with individual moths laying up to 4 000 eggs; however, the average number per moth is about 1 700.

Egg masses are seldom laid directly on host plants, and are more commonly found on adjacent vegetation. Citrus, eucalypt, papaw leaves, etc., are favoured backyard oviposition sites but eggs may also be laid on the walls and under the eaves of buildings. Egg masses occur on both upper and lower surfaces of the leaves, usually within a few metres of the ground.

Egg development within a single batch is generally quite uniform. Consequently, larvae hatch more or less simultaneously. Young armyworms have well developed 'silk glands', and may use 'silk threads' to lower themselves to the ground.

They tend to prefer sheltered feeding sites. Feeding commences almost immediately after hatching and continues at night until larval maturity. If disturbed, they react by curling into a tight spiral.

Lawn armyworms spend most of the day in concealment near the soil surface. For this reason, a heavy irrigation or storm will often force larvae up on to plant stems and leaves during the day. They are not cannibalistic and exhibit a tendency to be gregarious (group together). An 'army type' movement along a front often develops from this habit.

### Damage

Crop damage is directly related to the size and number of larvae and the stage of plant development when attack occurs.

It is the final three larval instars which are responsible for the most severe damage. The last instar is particularly voracious. Only the aerial plant parts are affected, the root system being left intact. The root system forms the basis for fresh growth after armyworms have been controlled and, therefore, liberal nitrogen fertilization and irrigation will often assist plant recovery.

In practice, it is normally the sudden appearance of injured crop plants or brown patches of grass which initially attracts attention to lawn armyworm activity.

### Seasonal occurrence

The pest is undoubtedly most active in mid to late summer. However, it also occurs in small numbers during the cooler months of the year.

Warm conditions favour growth and development. At 27°C, eggs hatch in 2 to 3 days and the whole life cycle from egg to adult can occur in less than a month. Rapid development plus the ability to lay large numbers of eggs allows damaging armyworm populations to build up very quickly.

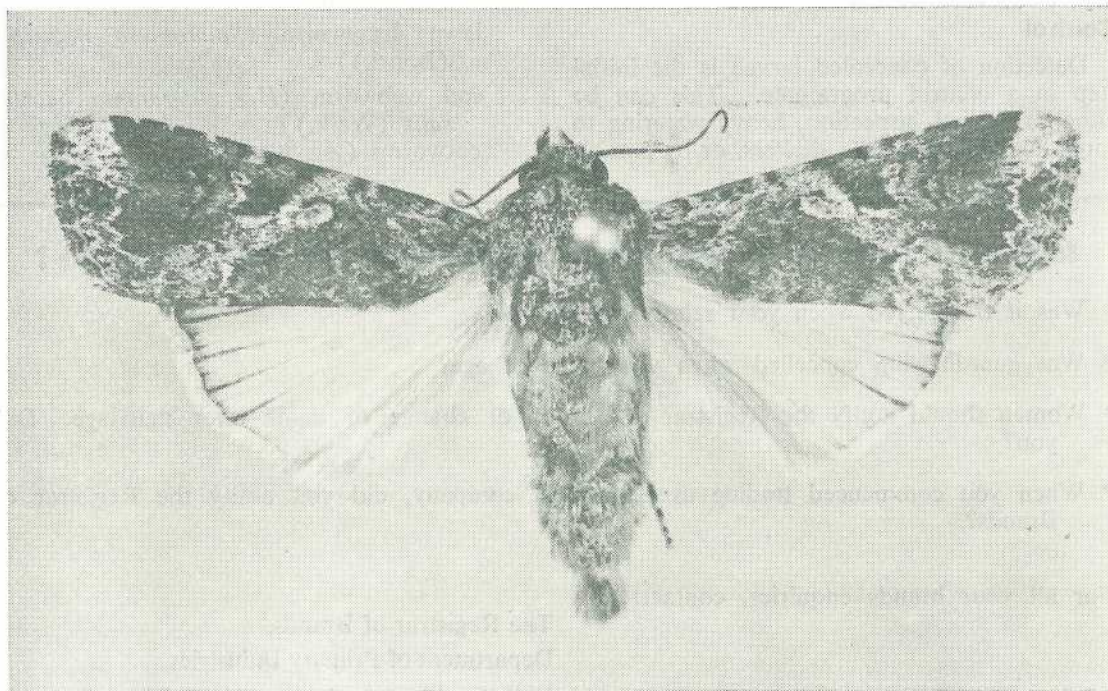

*The adult lawn armyworm moth.*

## Confusion with other species

Identification of the lawn armyworm is difficult as marked colour changes occur during larval development. The striped, younger larvae may not be readily associated with older armyworm larvae, which have two distinctive rows of dark triangles on their upper body surface. In addition, larvae of several other insect species feed in the same environment as the lawn armyworm, the most common being the sod webworm and cutworms. Neither of these, however, have the characteristic triangular lawn armyworm markings.

## Natural enemies

The armyworm has a number of natural enemies, which can often significantly affect armyworm populations. Among these are species of parasitic flies (family Tachinidae), and wasps (families Ichneumonidae, Scelionidae, Braconidae), and ants (family Formicidae), a fungus (*Spicaria rileyi*), a protozoan (*Nosema* sp.) and a nuclear polyhedrosis virus. In addition, cane toads (*Bufo marinus*) and many species of birds are active predators of larvae.

## Control

Detection of concealed larvae is the initial step in a control programme. This can be either by visual inspection, heavy watering to force larvae out of their shelters, or by placing

a moist bag on the ground surface overnight—in this case, larvae will congregate under the bag. In infested crops, inspection at night may reveal feeding larvae.

As larvae usually do not commence feeding until dusk, spraying during late afternoon may be more beneficial than pesticide application early in the day. Trichlorfon 550 g a.i. per ha, chlorpyrifos 350 to 450 g a.i. per ha, malathion U.L.V. 830 g a.i. per ha, and carbaryl 550 g a.i. per ha, will control lawn armyworms. Carbaryl 500 g a.i. per litre, a relatively non-toxic material, is registered for use in suburban areas at the following rates:—

Bowling greens—1 l in 500 to 1 000 l of water for a full-sized green.

Golf greens: 65 ml in 35 to 70 l of water for 100 square metres (that is, an average green of 372 square metres requires 250 ml in 120 to 140 l of water).

Tennis courts: 220 ml in 120 to 140 l of water for the court plus 1 metre outside the double lines.

Scientific names of pests mentioned in this article are as follows:

lawn armyworm (*Spodoptera mauritia* (Boisd.))

sod webworm (*Herpetogramma licarsalis* (Walk.))

cutworms (*Agrotis* spp.)

---

## Is the brand you are using registered in YOUR name?

- Was it transferred when your relative died?
- Was guardianship cancelled when you came of age?
- Women should notify the Registrar of Brands of change of name after marriage. Did you?
- When you commenced trading as a pastoral company, did you notify the Registrar of Brands?

For all your brands enquiries, contact:

The Registrar of Brands,  
Department of Primary Industries,  
William St.,  
Brisbane, Q. 4000.

# Electric fence controls wallabies



WALLABIES were successfully kept out of a green cereal crop during winter 1977 by a high-powered electric fence.

Graingrowers in many parts of Queensland have suffered heavy crop damage from wallabies in recent years. Because of this, the Queensland Graingrowers' Association provided the cost of fencing materials that were used in a small observation trial.

Approximately 12 wallabies were initially allowed to graze a 0.2 hectare area of barley and snail medic. The crop had been planted in a small clearing up on range country where the wallabies normally grazed.

The crop, contrasting with the adjacent dry native pasture, had been protected during growth by a chain wire fence. In July, this fence was taken down on two sides and replaced by a low five plain wire electric fence. The current was left off so that the wallabies were virtually unhindered in entering the crop area.

## Observations

When observed from a tower in the late afternoons and evenings, most of the 12 or so wallabies that were eating the crop entered through the second and third wire spaces from the ground.

The current was switched on while some wallabies were grazing the paddock. These went through the fence with apparently no difficulty.

However, when approaching the crop area from the outside, it was a different story.

*Photograph above. Inspecting an electric fence tester at the Hermitage Research Station Field Day are (from left): Dr. Graham Alexander, D.P.I.; Dr. Tom Kirkpatrick, National Parks and Wildlife Service; Ken Howard, D.P.I.; and graingrowers Messrs. Clinton Condon and David Wright.*

by K. F. HOWARD,  
Beef Cattle Husbandry Branch.

One wallaby was seen to touch the live fence with his fore paw and jump back about a metre. He tried three times at different spots. On each occasion he jumped back and then left the crop area.

After being switched on continuously for 7 days, only one wallaby was seen to enter the paddock. This was a small wallaby which always went under the bottom wire (earth) at a depression where the space was 175 mm (7 in.).

Of the wallabies that approached the fence, some were seen to receive a shock and move on while others simply looked and moved on—apparently having previously received one or more shocks.

During the second week of electrification, no wallaby was seen to enter the enclosure—except for the one going underneath.

After the third week (towards the end of August), the current was switched off as by this time all of the wallabies had lost interest in entering the enclosure though an attractive crop was still available.

A further 6 weeks passed before the wallabies ventured back into the crop through the still inactive wires.

The electric fence gave a high measure of control but emphasised the need for a uniformly

low bottom wire. If this earth wire is kept within 100 m (4 in.) from the ground, it forces the wallaby to consider the next two spaces which are 125 and 175 mm (5 and 7 in.).

A further trial is planned to observe if wallabies can be kept out with a much lower fence using only three wires.

### Fence details

Five plain wires. 12½ gauge galvanized, high tensile wire.

Wire heights from the ground were 100, 225, 400, 575 and 800 mm (4, 9, 16, 23 and 32 in.). Posts 1 350 mm long, driven 450 mm.

Earth and live wires alternate beginning with the wire closest to the ground being an earth. Sawn, light ironbark posts (25 x 38 mm) were used requiring no insulators. The cost of such a fence is approximately \$200 per kilometre for labour and materials.

The energizer was a Gallagher Bev. II with an output of 4,600 volt and a 30 to 40 amp pulse each second. This was donated by Toowoomba electric fence importers, Plant and Plant.

Pamphlets on the design and operation of electric fences are available from Department of Primary Industries' offices.

---

## Cattle earmarks

Did you know that:

- Cattle earmarks can only be registered **in conjunction with** a three piece horse and cattle brand?
- Cattle earmarks must not be made on a beast **unless** the beast has been branded with a three piece, or symbol, horse and cattle brand?
- Cattle earmarks are registered by district and cannot be used outside the district for which they are registered?

For further information on the registration and use of cattle earmarks contact:

**The Registrar of Brands,  
Department of Primary Industries,  
William St.,  
Brisbane, 4000.**



# Lupins in the South Burnett



by A. HODGE, Agriculture Branch.

A crop of *Unicrop lupins* in full flower on Mr Neil Johnston's Maidenwell property.

LUPINS are a relatively easy and trouble free crop to grow and should fit into most South Burnett farming programmes where there is a need for a legume phase or a cheap form of high protein palatable food.

Surplus lupins are readily accepted by local stockfeed manufacturers.

## Introduction

Lupins as a crop have a very long history. *Lupinus albus* has been cultivated as a grain legume for 3 000 years or more in the Mediterranean basin and parts of the Middle East.

*Lupinus angustifolius* although not cultivated was known in the Mediterranean region in the eighteenth and nineteenth centuries where it was used as a coffee substitute or adulterant. Our present day lupin owes much to the cultivation of *L. albus* and *L. angustifolius* because of experiments started in the eighteenth century in Germany.

Lupins were introduced into Australia early in our history and there is a record of a mill for grinding lupins in an early convict settlement in Western Australia. Modern breeding of lupins as grain and forage crops really started in 1928-29 when the first alkaloid-free or 'sweet' lupins were developed.

Dr J. S. Gladstones of Western Australia developed improved strains of the narrow-leaved lupin (*L. angustifolius*) releasing firstly Uniwhite, then Uniharvest and Unicrop during the last two decades. It is only recently that lupin growing has spread to the eastern States of Australia.

As a grain crop, lupins have been grown in south-east Queensland since 1972 when trials were conducted at Wyreema on the eastern Darling Downs. Testing of varieties was expanded to Biloela, Emerald, Kingaroy and the Granite Belt in 1974.

There has been a general expansion of the crop in the South Burnett since 1974. However, as a winter crop it only occupies a very small area when compared to barley and wheat.

Due to decreasing grain prices and the demand for a cheap source of protein, it appears that lupins can play an important part in the winter cropping programmes.

#### Varieties available

- *L. albus*. A broad-leaved lupin with white flowers tinged with blue. It has large white or pinkish-white, permeable flat seeds and non-shattering pods. Varieties available are:
  - Kiev—The quickest maturing variety available. The plant is normally shorter than other varieties and has a low vernalisation (the exposing of plants to periods of low temperature in order to induce them to develop rapidly when the temperature is raised) requirement.
  - Ultra—A quick-maturing variety well suited to the South Burnett that also has a low vernalisation requirement.
  - Hamburg—A slow-maturing variety with a medium vernalisation requirement.
- *L. angustifolius*. A narrow-leaved or New Zealand blue lupin. It has few hairs on leaf or stem and smooth, almost round seeds. The varieties available all have white flowers. The pods are non-shattering.
  - Unicrop—A quick maturing variety suitable for the South Burnett and having a low vernalisation requirement.
  - Uniharvest—A slow-maturing lupin with a high vernalisation requirement.

Marri—Similar to Uniharvest but resistant to brown leaf spot (*Pleichaeta setosa*).

Ultra and Unicrop being quick-maturing varieties are better suited to the South Burnett. Kiev may also be suitable but has not yet been adequately tested. If these preferred varieties are not available and the slower-maturing varieties have to be sown, planting must be a month earlier.

#### Soils

Lupins must be grown on well-drained soils. They will not tolerate waterlogging. The soil should be moderately acid to neutral (pH 5 to 7.0) in both surface and subsoil. Plough pans will restrict root penetration.

Lupins have been grown on very infertile soils when given adequate fertilizer but lupins respond well to high inherent fertility.

In the South Burnett, the heavier soil types, provided they are not subject to waterlogging, produce the best crops. This is because of their higher fertility and their higher moisture holding capacity.

#### Fertilizers

**Nitrogen** is not required when lupins are correctly inoculated. Lupins should be inoculated with the strain of *Rhizobium* bacteria recommended. As manufacturers use different codes, it is always advisable to order the inoculant by name rather than by the code.

**Phosphorus** in adequate quantities is essential for satisfactory lupin growth. Superphosphate is required when soil tests show less than 40 parts per million phosphorus. No phosphatic fertilizer should be required on most of the dark grey or black soils of the South Burnett, but up to 65 kg per ha may be required on other South Burnett soils.

**Potash** would be required on known deficient soils at rates of up to 25 kg per ha of potash.

#### Planting time

Lupins should be planted as early as possible to make use of the extra warmth at the end of the summer. This gives the lupins a strong initial growth which enables them to compete better with weeds and allows better growth during the winter period.



The seed size difference between *L. albus* and *L. angustifolius*. Forty seeds of each. *L. albus* is the larger seed.

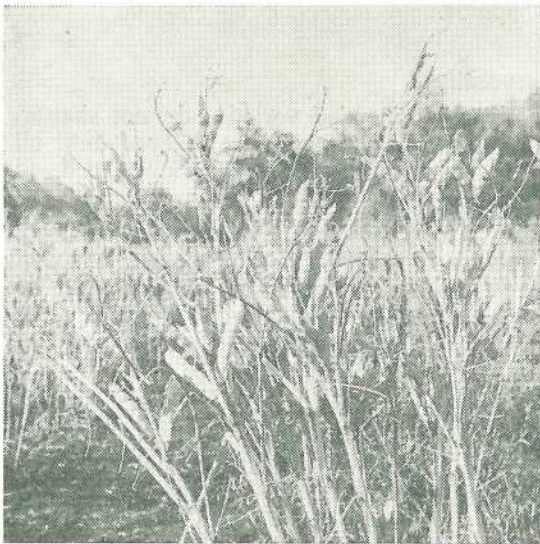

Plants of the variety *Ultra* ready for harvest. All leaves have been dropped and only the stalk and pods remain.

### Planting rate

Under dryland conditions, a planting rate of 60 to 75 kg per ha is adequate. Under irrigation, this rate could be increased by at least 25%.

The recommended dryland planting rate would give a plant population of 28 to 33 plants per m<sup>2</sup> in *L. angustifolius* and 15 to 18 plants per m<sup>2</sup> in *L. albus*. The planting rate is low when compared to other areas, but this is essential due to the poor moisture holding capacity of most soils in the South Burnett. The seeding rate can be increased where soil moisture reserves and the moisture holding capacity of the soil is high.

### Planting depth

Lupins should be planted at a depth of 50 mm in moist soil. Deep planting is not recommended as emergence will be reduced.

Lupins should not be rolled or the ground compacted in any way as this will also reduce emergence. Light covering harrows will help to level out any ridges of soil which can give a false depth of soil over the seed. If press wheels are used they should be of the split wheel type followed by light covering harrows.

Lupins can be planted through most planting equipment although some difficulty may be found with the larger-seeded *L. albus* varieties. These difficulties can be further aggravated as the seed has a tendency to bridge when covered with inoculant.

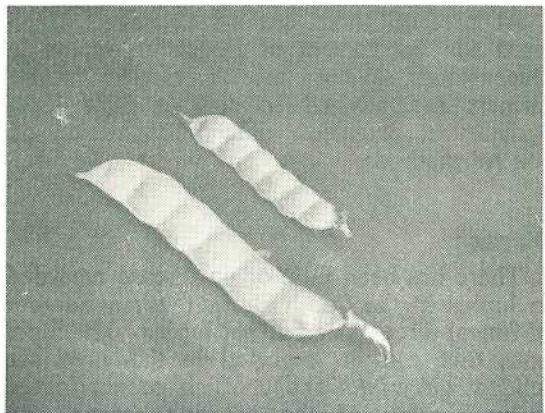

The difference in pod size between *L. albus* and *L. angustifolius*. *L. albus* is the larger pod.

Hamburg, Uniharvest and Marri should be planted before the end of April. *Ultra* and *Unicrop* should be planted in May and *Kiev* can be planted in late May.

Later plantings do not allow for sufficient growth before flowering commences.

## Row spacing and weed control

The main factor which governs row width is weed control. Lupins can be planted by a combine in 18 to 36 cm rows if the area is known to be weed free.

Where weeds can be expected and inter-row cultivations are necessary, the row widths should be adequate to allow the cultivations. This commonly gives a row spacing between 70 and 90 cm. Such row spacings can cause trouble with the larger-seeded varieties due to seed size and the close intra-row spacing required for optimum crop populations.

As yet, no herbicide is registered for use on lupins in Queensland. Trifluralin and Simazine are registered elsewhere for use in lupins.

## Insect pests

A number of insects can attack lupins but as yet there have been only limited cases in the South Burnett. The attacks were not so severe as to warrant control measures.

**Cutworms** (*Heliothis punctigera*) causes bleaching of the leaves but seldom warrants control. Aphids (*Aphis* spp.) seldom attack lupins and then only in patches.

**Green vegetable bug** (*Nezara viridula*) will cause damage to pods by stinging, causing pod shrinkage and discolouring the seeds, and lucerne seed web moth (*Etiella behrii*) larvae can cause extensive damage to the seeds.

At present, there are no chemicals registered for the control of insects in lupins in Queensland. When insects attack lupins, farmers are advised to contact their local agricultural extension officer for advice on control methods.

## Diseases

There has been little or no disease recorded in lupins in the South Burnett but a number of fungal diseases can attack lupins. The main ones that can be expected in this area are mildew (*Erysiphe* spp.) which occurs in the warmer parts of the growing season and *Sclerotinia* which occurs in cold, moist conditions. Other fungal diseases can be found

as seedling diseases of lupins and in older plants. In most cases, well grown lupins will be relatively free of diseases.

Two other diseases causing major losses elsewhere are brown leaf spot (*Pleiochaeta setosa*) which occurs in cool, damp conditions (the only variety available with resistance is Marri) and anthracnose (*Glomerella cingulata*) has a wide host range besides lupins. It is only serious under warm, moist conditions.

Of several viruses recorded as infecting lupins only two appear to be a field problem. These are bean yellow mosaic virus (BYMV) and to a lesser extent, cucumber mosaic. These viruses are transmitted by aphids. The recommended varieties are only slightly susceptible to aphids.

## Harvesting

The recommended varieties do not shatter. This allows harvesting to be delayed until all pods are ripe and the seeds have dried to a storage level of 12% moisture.

A normal combine harvester can be used. Comb front headers should have every second finger removed. The drum speed should be slow, concave opened to avoid damage to the seeds and the ground speed should also be slow.

If lupins are left standing in the field until all the seeds are dry, the pods tend to become brittle. This brittleness can be largely overcome by harvesting in the cooler part of the day.

Augers should be used as little as possible during harvest and storage as seed can be damaged and germination affected. Belt elevators which are used for navy beans and peanuts are ideal for handling lupins.

## Economics

In the South Burnett, a farmer can expect to grow 2 500 kg per ha of barley. Under similar conditions, a yield of 1 800 kg per ha of lupins could be expected. The cost of establishing 1 ha of lupins is about the same as planting barley over the same area and hence the return offered for lupins would have to be 54% greater than the price of barley. In most years, this could be expected.

## Lupins in feed mixes

Lupins can be considerably more valuable to a farmer who could use them to replace dearer protein feeds in his stockfeed mixes.

Lupin grain is high in protein content in the whole seeds (*L. albus* 36% and *L. angustifolius* 28%). The protein levels are higher than in the seeds of most grain legumes such as peas, beans, and vetches, but are lower than in most oilseed meals.

Lupin seeds have a fairly high level of crude fibre which is contained almost entirely in the seed coat. This crude fibre is highly digestible. The removal of the seed coat by commercial milling procedures (80 to 90% removal) can appreciably increase the crude protein level. *L. albus* has a fibre content of 13.4% and *L. angustifolius* 18.4%.

In most rations, it would be the soybean meal which is replaced by lupin meal. Soybean meal fluctuates in price but \$350 can be assumed as being the average price during the year.

The following rations have been formulated by officers of Dairy Field Services, Pig and Poultry and Beef Cattle Husbandry Branches stationed at Kingaroy:

## Dairy cows

A suggested feed ration containing 16% crude protein:

- 70 kg grain—barley, maize or sorghum at 10% crude protein.
- 20 kg lupin meal.
- 10 kg peanut meal.
- 1 kg bone char.

If acceptability problems arise, the ration could be altered to 10 kg lupin meal and 20 kg peanut meal.

A dairy cow requires 1 kg crude protein per day for maintenance plus 13.5 litres of milk.

## Pig rations

Rations for breeding stock and growing pigs are:

### • BREEDING STOCK

- Any grain .. .. . 50 kg
- Lupin .. .. . 50 kg
- Christmas Island phosphate .. 2 kg
- Ration fed at 1.8 kg per breeder per day.

### • GROWING PIGS

A number of rations are given to enable the farmer to formulate the cheapest ration available at the time of mixing. The rations are mixed as units of weight.

RATION No.

Ingredient	1	2	3	4	5	6
Wheat .. .. .	73			66.5		
Barley .. .. .		82			73.5	
Sorghum or maize .. .. .			67			59.5
Fish meal .. .. .	5	6	6			
Meal and bone meal .. .. .				9	9	9
Soybean oil .. .. .				4	7	6
Lupins .. .. .	20	10	25	20	10	25
Christmas Island phosphate .. .. .	1.5	1.5	1.5			
Methionine .. .. .	0.06	0.07	0.125	0.06	0.07	0.125
Salt .. .. .	0.25	0.25	0.25	0.25	0.25	0.25
Minerals and vitamins .. .. .	Add	Add	Add	Add	Add	Add

Ration fed at up to 2 kg per pig per day.

## Beef cattle

Daily rations that could be used using lupins: 270 kg liveweight yearling steer (expected daily weight gain 1 to 1.3 kg).

Sorghum stubble .. ..	1.4 kg
Lupins .. ..	0.7 kg
Sorghum—grain .. ..	6.0 kg
Limestone .. ..	0.03 kg
Salt and additives .. ..	0.045 kg
Urea .. ..	0.06 kg
Christmas Island phosphate	0.03 kg

450 kg liveweight steer (expected daily weight gain 1 to 1.4 kg)

Sorghum stubble .. ..	3.0 kg
Lupins .. ..	0.9 kg
Sorghum grain .. ..	8.0 kg
Limestone .. ..	0.045 kg
Salt and additives .. ..	0.045 kg
Urea .. ..	0.06 kg
Christmas Island phosphate	0.03 kg

Supplementary feeding on old standing grass.

Dry cattle ..	0.025 kg lupin/head/day
Lactating animals	0.4 kg lupin/head/day

---

## Joining wall to floor

Jointing poses the biggest problem in maintaining water-tightness of concrete tanks and dips. Whenever possible, make the placing of concrete continuous. Where a continuous pour is not possible, it is most important that the correct procedure be carried out to avoid bad joints between the concrete surfaces, such as wall to floor.

The old surface should be prepared by roughing it up with a stiff broom before it has set; the surface should be cleaned so that soft mortar is removed and coarse aggregate exposed. If the surface is already hard, it should be chipped and thoroughly cleaned. Before adding the new concrete, the old surface should be dampened and slushed with a coat of neat cement cream.

The next layer should be a mixture in which the coarse aggregate is about half the amount used in regular concrete. For instance, a water-tight joint mix is 3 sand and 1½ gravel. By laying it to about 12 cm, stone pockets can be avoided at the bottom of the new layer thus improving the bond with the hardened concrete. This must be placed in position before the cream sets.

When using a vibrator, place in the centre of concrete wall. Spading or rodding is against the mould surfaces only. This will not only consolidate the concrete but will avoid stone pockets on the finished concrete wall surface.

*by H. Woodings, formerly of Agriculture Branch.*

# Creeping bluegrass finds favour

by W. J. Bisset, Agriculture Branch and T. G. Graham, formerly of Agriculture Branch.

AN introduced grass which was discarded after official testing more than 30 years ago has since found favour with commercial producers.

Hardiness and ease of establishment are two key attributes of creeping bluegrass. There are now 2 000 hectares of it distributed over half a dozen properties near Rockhampton.

It is also showing promise in drier areas, where it readily establishes on heavy self mulching soils.

## Origin

Creeping bluegrass (*Bothriochloa insculpta*) is a native of tropical and sub-tropical Africa excluding West Africa. It is known as 'sweet pitted grass' in Kenya and as 'pinhole grass' in Rhodesia and South Africa. It occurs naturally in pastures over a range of soil types including heavy-textured black soils and hard-setting soils, and is recommended for planting on the former. The lower rainfall limit is claimed to be around 600 mm and the grass is reported to be tolerant of drought and heavy grazing.



A young stand of creeping bluegrass showing prolific runner development.

## History in Queensland

The creeping bluegrass present in Queensland is believed to have originated from seed introduced by C.S.I.R. (now C.S.I.R.O.) from Southern Rhodesia in 1931. Over the next few years it was grown by C.S.I.R. and the (then) Department of Agriculture and Stock (D.A.S.) in plots at St. Lucia (D.A.S.), Gatton College (C.S.I.R.), Toowoomba (D.A.S.) and Rockhampton (C.S.I.R. and D.A.S.). At Rockhampton, it was grown at the Fitzroyvale Field Station (C.S.I.R.) during the period 1936 to 1946.

Creeping bluegrass proved to be a vigorous grower, and at Fitzroyvale it outyielded all other grasses tested. However, it was finally rejected because of a poor showing in a palatability trial.

Towards the closure of Fitzroyvale, local producers were offered planting material of a number of grasses for testing on their properties. Mr O. L. Hassell, of the D.A.S. at Rockhampton, assisted them with their selections. One of the farmers involved was Mr

Garney Hatch of The Caves who planted his selections in some unplanted maize rows.

After several years, Mr Hatch observed that creeping bluegrass was the sole survivor of the six or seven grasses planted and was spreading of its own accord. Besides this, it was green and growing in early winter when the native grasses had hayed off. He then planted some in a cleared brigalow scrub area where a poor strike of Rhodes grass (*Chloris gayana*) had occurred. Within a few years this new grass had spread over a considerable area and had begun to invade adjacent speargrass (*Heteropogon contortus*) country. Neighbours became interested and established areas of 'Garney's' grass as it came to be called.

Mr S. Johnson was the first to harvest seed in quantity, and this was eagerly sought after by two graziers in the Rossmoya area for large scale planting. Mr A. Todd established 1 200 ha on a low phosphate red loam at 'Greenlake' after clearing and burning the scrub. The seed was sown aerially in a mixture with Rhodes grass and green panic (*Panicum maximum* var.



A pasture of creeping bluegrass and Siratro at Alton Downs.



*trichoglume*). These two grasses have since disappeared, but creeping bluegrass now forms a solid stand over most of the area. Mr W. Tennent has 400 ha on 'Doonside' and 'The Springs'. Another 400 ha is spread over four or five properties at The Caves.

Creeping bluegrass first became known to one of us (T. G. Graham) in 1959, and since 1964 it has been included in the range of grasses grown in observation plots in central and southern Queensland.

Favourable establishment and growth on brigalow soils near Rockhampton led to successful sowings on self-mulching black soils at Emerald in 1970, and this performance was soon repeated on the Darling Downs.

In 1976, creeping bluegrass was recommended for registration by the Queensland Herbage Plant Liaison Committee under the cultivar name 'Hatch'. Registration procedures are progressing.

## Description

In general appearance, creeping bluegrass resembles two well known native bluegrasses which are widespread in the better class forest country of sub coastal and inland areas of central and southern Queensland. These are forest bluegrass (*Bothriochloa bladhii*) and desert bluegrass (*B. ewartiana*).

A feature of all three grasses is the distinctive scent given off by the leaves, stems and seed-heads when crushed, and which persists in hay. Characters which distinguish creeping bluegrass from these native bluegrasses are its conspicuously hairy nodes (stem joints), the reddish-purple colouring of exposed stem portions, and the development of creeping (as well as upright) stems.

The upright stems can grow to a height of more than 1 m and the creeping stems (which finally turn upwards) to a length of more than 2 m. Under heavy grazing, the grass will form a close sward after the manner of pangola grass (*Digitaria decumbens*).

TABLE 1  
How to distinguish creeping bluegrass from angleton grass and sheda grass  
Refer also to the drawings.

Plant part	Creeping bluegrass	Angleton grass	Sheda grass
Crushed leaves and stems	scented	not scented	not scented
Hairs on nodes (stem joints)	long	short or absent	long
Seedheads	no hairs at base of branches	base of branches covered with short downy hairs	no hairs at base of branches
Seeds	hull has a pit on one side	hull not pitted	hull not pitted

The seedheads are reddish-coloured with from five to twenty branches. Each branch carries numerous paired spikelets (flowering units). The lower spikelet of each pair is fertile, carries an awn, and has a deep pit on one side. The upper spikelet, which is sterile, is carried on a short, hairy stalk and has two shallow pits on one side.

The spikelets of forest bluegrass and desert bluegrass are sometimes pitted but the pits are less conspicuous than in creeping bluegrass.

Two other introduced 'bluegrasses' which are naturalized in central Queensland can easily be confused with creeping bluegrass. These are angleton grass (*Dichanthium aristatum*) and sheda grass (*D. annulatum*). Table 1 shows how creeping bluegrass can be distinguished from these.

## Main features

### • Growth

Creeping bluegrass is a summer-growing perennial. It continues to grow into early

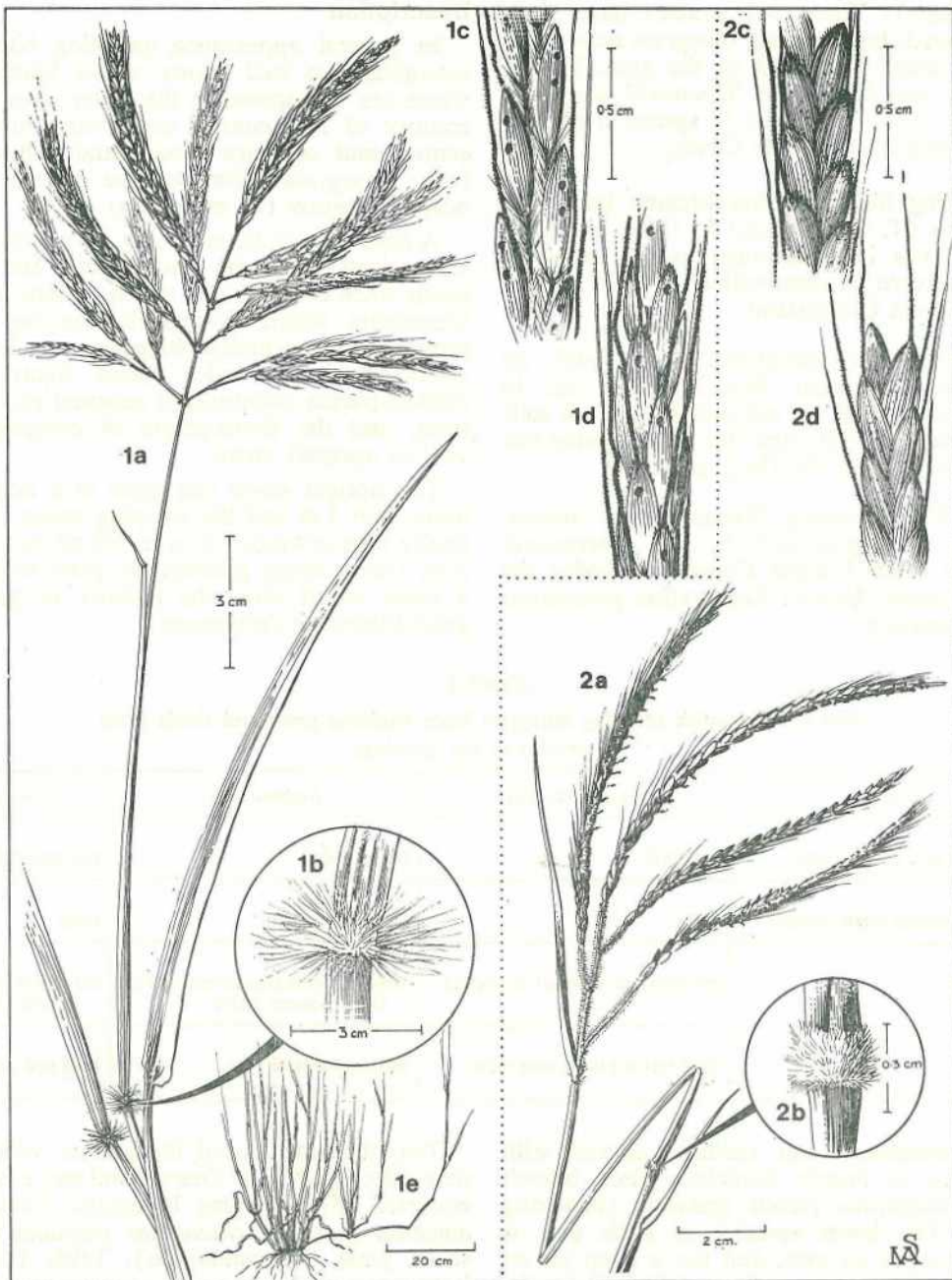

1—Creeping bluegrass (*Bothriochloa insculpta*)

2—Angleton grass (*Dichanthium aristatum*)

a—Upper portion of stem with seedhead. Note the fine hairs at base of seedhead of angleton grass.

b—Node (stem joint) showing long hairs in creeping bluegrass and short hairs in angleton grass.

c—Portion of branch of seedhead showing upper (sterile) spikelets. Note the pair of pits in creeping bluegrass.

d—View of c from other side showing lower (fertile) spikelets. Note the pit in creeping bluegrass.

e—Tussock of creeping bluegrass with a creeping stem.

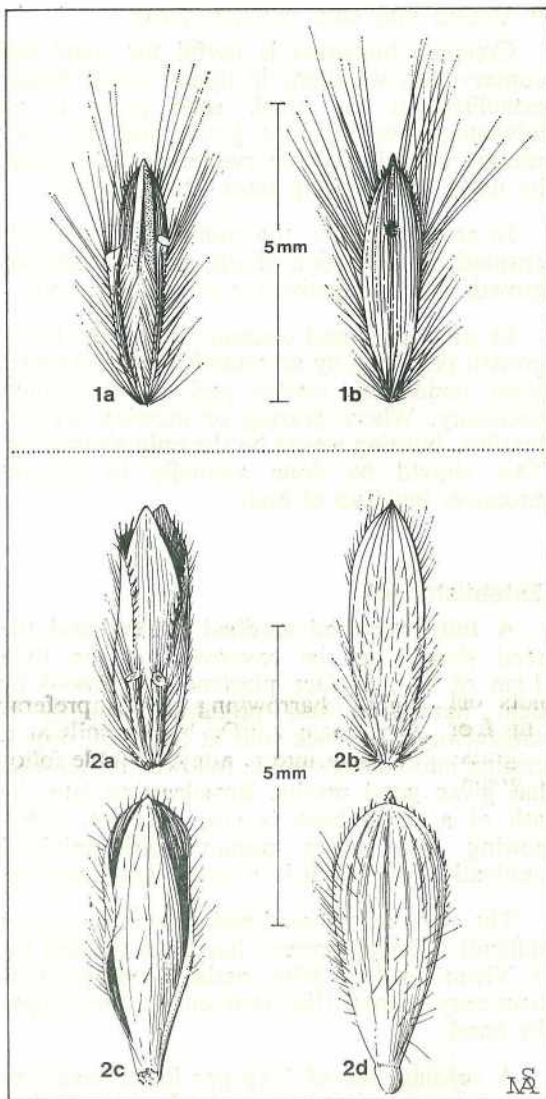

1—Creeping bluegrass.

2—Angleton grass.

a and b—Two views of seed.

c and d—Two views of sterile spikelet of angleton grass.

winter until cut by frost, but is slow in coming away in spring compared to Rhodes grass and green panic.

In contrast to Rhodes grass, the runners of creeping bluegrass do not take root readily,

even when lying on bare soil. Rooting is improved by prolonged wet weather, trampling by stock or coverage by soil.

The grass has two flowerings in a year; the main flowering commences in late April, and the second (on new season's growth) in late spring.

#### • HARDINESS

An outstanding feature of creeping bluegrass is its ability to compete with native grasses on forest country without nitrogen fertilizer. This is well illustrated by the results of an observation trial planting of creeping bluegrass and ten commercial tropical grasses on spear-grass country at Miriam Vale in 1965. The grasses were established in single rows after cultivation and application of superphosphate. Two years later all the commercial grasses (including angleton grass) had virtually disappeared, but creeping bluegrass was flourishing and had spread about 1 m on either side of the planted row.

Up to this time, grazing of the plots had been restricted. Then the fence was removed and the trial area has since formed part of a station paddock. After 10 years of preferential grazing, the patch of creeping bluegrass has remained intact among the surrounding speargrass.

Although able to tolerate a low soil nitrogen level, creeping bluegrass responds readily to nitrogen fertilizer. The response is evident in improved herbage yield, leaf colour, and seed production.

#### • SOILS

In Queensland, creeping bluegrass grows on a wide range of soils including eroded clays, scalded areas, and puggy soils. It grows better on loams and clay loams than on sandy soils and will not thrive under waterlogged conditions.

Creeping bluegrass shares with angleton grass a superior ability to establish on self-mulching black soils compared to Rhodes, green panic, buffel (*Cenchrus ciliaris*) and Makarikari panic (*Panicum coloratum*). In trials conducted over 4 years at Emerald and near Toowoomba, it has consistently outyielded these grasses with or without application of nitrogen fertilizer.

## • LEGUMES

There are many examples from commercial pastures around Rockhampton of successful combination of the legume Siratro (*Macroptilium atropurpureum*) with creeping bluegrass. These show an obvious benefit to the grass in improved colour. Siratro will spread into the grass from adjacent plantings. On a soil suited to Townsville stylo (*Stylosanthes humilis*), this legume has spread into creeping bluegrass under normal grazing.

## • PALATABILITY AND GRAZING VALUE

Digestibility trials carried out with sheep in Kenya showed that both creeping bluegrass and Rhodes grass are moderately digestible in the young growth stage, and that creeping bluegrass has a lower protein content than Rhodes grass at all growth stages. This is in line with the claim by Queensland farmers that it is a fattening rather than a milking grass.

The only grazing observations reported from 'Fitzroyvale' were made on mature growth. Cattle were admitted in August to plots of various grasses which had been locked up for the previous 12 months. Creeping bluegrass was found to be much less palatable than green panic, Gatton panic, (*P. maximum*), Makarikari panic, Rhodes grass and Gayndah buffel grass.

This was a severe test and it was biased against creeping bluegrass; all the other pastures had an effective legume content in the form of Schofield stylo (*S. guianensis*), which had failed to persist in the creeping bluegrass plots.

On the beef properties where creeping bluegrass is grown, palatability is not a problem. The reasons for this are:

- Creeping bluegrass is thriving on country which will not support green panic or Rhodes grass (for example 'Greenlake').
- Creeping bluegrass is certainly more palatable than speargrass and other native species and grows longer into autumn.
- It has been observed in trial plots that palatability of creeping bluegrass is markedly improved when grown with Siratro.

## • VALUE FOR SOIL CONSERVATION

Creeping bluegrass is useful for some soil conservation situations in inland areas. Ready establishment on black soils gives it an advantage over Rhodes grass, and the poor rooting capacity of the runners can be offset by using high seeding rates (9 kg per ha).

In erosion gullies, the rooting of runners is ensured by deposition of silt, and the vigorous growth is very effective for soil stabilization.

In waterways and contour banks, the bulky growth produced by an established stand under good conditions makes periodic defoliation necessary. Where grazing or mowing are not feasible, burning would be the only alternative. This should be done annually to prevent excessive build-up of fuel.

## Establishment

A fully prepared seedbed is best and the seed should not be covered by more than 1 cm of soil. Surface placement, followed by light harrowing and preferably rolling, is satisfactory. On black soils at Emerald, broadcasting into barley stubble followed by slashing has given good results. Broadcasting into the ash of a scrub burn is also effective. Overseeding into native pasture with minimal cultivation will result in a mixed grass pasture.

The awns on the seed make machine sowing difficult although success has been claimed for a Vicon seeder. With aerial seeding, it is necessary to push the seed out of the hopper by hand.

A seeding rate of 2 kg per ha of seed free of straw is recommended. In appropriate situations, Siratro, Townsville stylo or Verano caribbean stylo (*S. hamata*) may be included at 2 kg per ha.

The best time for sowing would appear to be from November to January inclusive, to take full advantage of the growing season and to enable seed to be set in the first season.

Superphosphate need not be applied unless the soil is grossly deficient in phosphorus. Where a legume is to be sown with the grass, however, the fertilizer needs of the legume have to be considered.



*ABOVE. Creeping bluegrass in seed on a brigalow soil on J. Hatch's property, The Caves.*

*BELOW. Cattle grazing creeping bluegrass on 'Greenlake' near Rossmoya.*



## Grazing management

As with most newly sown pastures, grazing should be withheld to allow quick development of the stand. On the other hand, trampling by stock when the runners are well developed will promote rooting down.

Because of its vigorous growth, an established stand of creeping bluegrass should be grazed well during summer to restrict the development of stemmy growth.

The pattern of grazing will vary with the legume component. In pure grass stands or where Townsville stylo is present, the pasture should be kept relatively short (no more than 10 to 15 cm high). Where Siratro is present, the pasture could be allowed to reach a height of 30 cm.

Carrying capacity of improved pastures based on Rhodes grass and green panic around Rockhampton is a beast to about 1.2 ha. Experience with creeping bluegrass is that it will carry and fatten just as well but will withstand more grazing pressure. Because of this, creeping bluegrass can be used to take the brunt of grazing during dry times, thus relieving the pressure on more sensitive grasses such as green panic and Rhodes.

The high yielding capacity of creeping bluegrass suggests the possibility of haymaking to utilize surplus growth. At present, the picture with regard to palatability of such hay is not clear. Hay made at The Caves has been rejected by dairy cattle but accepted by horses. On a property in the Emerald district, locally-grown hay is readily accepted by beef cattle (including weaners) and by horses, but rejected by sheep.

The best time to cut hay is in summer, before the growth becomes too stemmy. The hay would be a roughage rather than a high quality feed. However, the presence of Siratro would improve the quality.

## Freedom from harmful properties

There have been no reports of harmful effects in cattle or horses attributable to the grazing of creeping bluegrass, either in Queensland or in Africa.

It might be expected that the scent in the grass would taint milk, but this has not been reported over 25 years of use on dairy farms around Rockhampton.

There has been no suggestion of creeping bluegrass being a weed of crop or pasture land either in Queensland or in Africa.

## Seed production

For several years up to 2 000 kg of seed has been harvested annually on a casual basis by Messrs Hatch and Johnson. The pastures are grazed until late February and then locked up for development of the seed crop, which ripens in late May-early June. Harvesting is carried out by contract heading with yields of 10 to 30 kg per ha being obtained.

Yields are very low in years of poor March-April rain. In the very wet autumn of 1976, they were severely reduced by leaf rust (*Puccinia duthiae*). Early frosts are another hazard.

At the Department's Beerburrum Seed Production Unit, yields equivalent to 80 kg per ha have been achieved in small plots, using nitrogen fertilizer and strategic irrigation. As well, a second harvest is obtained in late November-early December.

Seed is ready for harvest when the branches of the seedhead start to close and their colour changes from reddish-purple to brownish-purple. Ripe seed falls readily, and losses can occur from wind, rain, and even heavy dew.

In practice, it is difficult to obtain a seed sample of greater than 50% purity even when all the straw is removed. Impurities consist of empty florets, bracts, and detached awns. These, plus the fact that the seeds contain short, hairy portions of seedstalk, make the seed mass light, fluffy and somewhat difficult to handle.

Tests have shown that the seed can be cleaned readily using a buffel seed cleaner and de-awned using a Townsville stylo 'de-awner'. To date, however, such processing has not been adopted by the present growers. While the awns may have some advantage for self-burial of surface-sown seeds on rough seedbeds, their removal would be a definite advantage for handling and machine sowing.

Germination tests have given a wide range of results, the best recorded to date being 71%. There are indications that germination can fall rapidly after 2 years under normal storage conditions.

## Contamination with angleton grass

A disability with seed produced in the Rockhampton area to date is contamination with seed of angleton grass.

Farmers around Rockhampton consider angleton grass inferior to creeping bluegrass, because of its shorter growing season and stemmier growth. On heavy-textured soils, angleton grass is aggressive and can compete strongly with creeping bluegrass, particularly in wet years. On lighter soils, creeping bluegrass will dominate angleton grass and on sandy soils the latter will not survive.

It is impossible at present to separate the seeds of angleton grass and creeping bluegrass from a mixed sample of the two. This emphasizes the importance of restricting commercial production of creeping blue grass seed to areas that are free from angleton grass.

In an effort to overcome the problem, the Department established a 'clean' seed plot at Beerburum in 1969. The seed used to establish this plot came from the dairy farm of Mr G. Tidcombe at Hervey Bay, who had been growing the grass since 1938. His original planting material (roots) came from Rockhampton (D.A.S.) via a neighbour, Mr R. Townsend.

Small quantities of seed produced at Beerburum have been distributed to various centres in central and south-east Queensland. Hopefully, this will result in production by some farmers of seed that is free of angleton grass.

## Prospects

Creeping bluegrass is firmly established on some 2 000 hectares in a 970 mm mean annual rainfall area near Rockhampton. It has proved successful in situations where green panic and Rhodes grass are either difficult to establish or fail to persist.

The grass seems adapted to a wide area of sub coastal central and southern Queensland especially on the heavier soil types. Its particular value in inland areas is establishment reliability on heavy soils. As yet we have no knowledge of its capacity to survive severe drought at centres as far inland as Emerald. However, its ability to survive droughts in the Rockhampton area has been amply demonstrated over the last 30 years.

It is worth mentioning that another introduced bluegrass naturalized in some areas of central Queensland is showing better promise for grassing contour banks and waterways. Its runners root down readily and its short stature poses no management problem. The name of this grass is Indian bluegrass (*Bothriochloa pertusa*) and it will be the subject of a future article.

The authors wish to express their thanks to (the late) Mr T. K. Kelly, Agriculture Branch and Mr C. C. Gillies, Soil Conservation Branch, for some of the information used in this article.

---

## Ginger Marketing Board election

Two of the three present grower members of The Ginger Marketing Board will continue in office for a further 3 years.

The Minister for Primary Industries, Mr V. B. Sullivan, said that when nominations of candidates for election to the new Board closed, Messrs H. C. Ham and N. A. Templeton had re-nominated.

Mr A. C. Frizzo did not seek re-election. Mr N. J. Kruger will replace Mr Frizzo on the Board.

Mr Sullivan said no election was necessary as three growers' representatives were required on the new Board, which will take office on July 16 next.

# Chemical weed control guide—winter cereals 1978

Compiled by S. R. Walsh and J. M. T. Marley, Agriculture Branch

THIS chart is a guide to the chemical control of weeds in winter cereal crops.

While chemical weedicides have a valuable part to play in supplementing mechanical weed control, they can never be used to replace cultural practices.

Each year, the number of chemicals commercially available increases. The successful use of these chemicals depends on a number of factors. These include the choice of the most efficient chemical, the correct timing of the spraying, and the rate and methods of application. Careful attention should also be given to applying the chemical at the correct stage of crop growth so that injury to the crop can be kept to a minimum.

It is important that the weed should be identified correctly before selecting the chemical to be used. The weeds listed in the guide are those that occur most frequently in winter cereal crops.

The explanatory notes below are most important and should be read in conjunction with this guide.

When applying weedicides, producers should take care to avoid spray drift.

Further information on weed control may be obtained from your local agricultural extension officer.

## Herbicide rates in millilitres per hectare

Cereal Weeds	Avadex BW	Treflan	Avenge 650 SP	Mataven	2,4-D Amine (50% W.V.)	MCPA (27% W.V.)	Tordon 50D	Tordon M	Brominil	Buctril MA Brominil M	Dicamba (20% W.V.)
Wild oats .. ..	*2 100	1 000	1.15 kg	3 000—4 000							
Paradoxa Grass ..		*1 000									
Climbing Buckwheat ..					1 100 (+W)	2 800	*470	*2 100	1 400	1 400	700
Wireweed .. ..		1 000			*1 700 (+W)		470+ 2,4-D (A)	1 400—2 100	1 400+ 2,4-D (C)	1 400	700
Turnip weed .. ..					*700	1 400	470+ 2,4-D (A)	1 400—2 100	1 400+ 2,4-D (C)	1 400	700+
Mustards .. ..					*1 100	2 100	470+ 2,4-D (A)	1 400—2 100	1 400+ 2,4-D (C)	1 400	2,4-D (C)
Radish§ .. ..											700+
Variegated thistle ..					*1 100	2 100	470+ 2,4-D (A)	1 400—2 100	1 400+ 2,4-D (C)	1 400	700
Saffron thistle .. ..					*1 700 (+W)	3 500				1 400	
Hexham-scent .. ..					*1 700 (+W)		470+ 2,4-D (A)			1 400	700
New Zealand spinach ..							*470				700
Spiny emex .. ..					1 700 (+W)		*470			1 400	700
Docks .. ..					1 700		*470	1 400—2 100			700



Cereal Weeds	Avadex BW	Treflan	Avenge 650 SP	Mataven	2,4-D Amine (50% W.V.)	MCPA (27% W.V.)	Tordon 50D	Tordon M	Brominil	Buctril MA Brominil M	Dicamba (20% W.V.)
Mintweed .. ..					*1 100		470+ 2,4-D (A)				700+ 2,4-D (C)
Sunflower .. ..					*1 100		470+ 2,4-D (A)				
Patterson's curse ..					*1 700						
Bindweed (perennial) ..					*1 700	3 800					
Hoary cress (perennial) ..					*1 700						
Mexican Poppy .. ..					*1 700					1 400	
<b>GROWTH STAGES FOR APPLICATION</b>											
Crop .. ..	pre-sowing	pre-sowing	not beyond mid tillering	early tillering to early jointing	tillering	tillering	early tillering	see note 24-25	2-leaf through tillering	3-leaf through tillering	tillering
Annual weeds .. ..	pre-emerge	pre-emerge	2½ leaf to fully tillered, prefer 2½-3 leaf	early tillering to jointing	young	young	young	young	young	young	young
Perennial weeds ..					pre-flowering	pre-flowering	pre-flowering		Not effective	Not effective	pre-flowering
<b>CROP TOLERANCE</b>											
Wheat .. ..	2 100	Not recomm.	yes	yes (see note 19)	2 200	5 600	tol	2 100	2 100	2 100	700
Barley .. ..	2 100	1 000	yes	no	1 700	4 200	tol	2 100	2 100	2 100	700
Oats .. ..	non-tol	non-tol	non-tol	non-tol	1 100	4 200	tol	2 100	2 100	2 100	700
Canary seed .. ..	non-tol	non-tol	N.A.	N.A.	1 100	N.A.	N.A.	N.A.	N.A.	N.A.	N.A.
Undersown lucerne ..	2 100	not recomm.	not recomm.	not recomm.	non-tol	non-tol	non-tol	non-tol	N.A.	non-tol	non-tol
Linseed .. ..		not recomm.	N.A.	no	not recomm.	1 400	non-tol	1 750	1 400	1 400	N.A.
<b>METHODS OF APPLICATION</b>											
Boom sprayer .. ..	yes	yes	yes	yes	yes	yes	yes	yes	yes	yes	yes
Aircraft .. ..	no	no	yes	no	yes	yes	yes	yes	no	MA no M yes	yes
Misting machine ..	no	no	no	no	no	no	no	no	no	no	no

NOTE:—

1. The treatment marked with an asterisk is the usual suggestion for cost efficiency.
2. (+W) indicates to add non-ionic wetting agent at 1 part of 50% to 60% product to 1 600 parts of spray mixture.
3. 2,4-D and MCPA formulations vary in the percentage of active ingredient—check the label and adjust the rate accordingly.
4. Tol. indicates the crop is normally tolerant at the suggested rates of application.
5. Not recommended indicates the chemical should NOT be used on this crop as crop damage may occur.
6. N.A. indicates crop tolerance data not available.
7. 2,4-D esters must NOT be used in declared hazardous areas.
8. +2,4-D (A) indicates add 470 ml per hectare of 50% 2,4-D amine.

9. +2,4-D(C) indicates add 700 ml per hectare of 50% 2,4-D amine. When 2,4-D is added to Brominil, application must be restricted to the tillering stage of the crop.
10. For linseed and safflower, Avadex at the rate of 2 100 ml per hectare is recommended as a pre-sowing application for wild oats control. It is cheaper than Avadex BW but **SHOULD NOT** be used on wheat or barley.
11. § For adequate control of radish extra 2,4-D above the rate indicated in this guide may be required. Consult your agricultural extension officer.
12. Some chemicals have a residual activity and may restrict the choice of the subsequent crop. Consult the manufacturers' labels.
13. For cereals undersown with lucerne, 2,4-DB may be used to control some broad-leaved weed species. Consult your agricultural extension officer.
14. Sprays should be thoroughly mixed before application.
15. To convert millilitres per hectare to pints per acre divide by 1 400.
16. Avenge or Mataven should not be mixed with any other weedicide.
17. The best results are obtained from post-emergence wild oat sprays if both the crop and the oats are growing vigorously. Crop competition is important for subsequent control.
18. It is important that the recommended rate of surfactant (wetting agent) be added to the Avenge. The required amount is contained in the commercial pack marketed by the company.
19. Do not spray Mataven on to wheat varieties Kite or Eagle after they have passed the full tillering stage. It may cause some stem shortening and yield loss.
20. Mataven should not be applied to barley.
21. Mataven should be applied by a ground boom spray.
22. After spraying with Mataven, the green crop should not be grazed or cut for stock fodder.
23. Do not use phenoxy type weedicides within one day of spraying with Avenge or 10 days of spraying with Mataven.
24. Tordon M is recommended for spraying linseed. The crop should be 8 cm–20 cm (3–8 in.) in height before spraying.
25. Some slight wilting may be noticed in linseed after spraying but this is only temporary.
26. Winter cereals should be in the early tillering growth stage.
27. **ALWAYS READ LABELS THOROUGHLY BEFORE USING CHEMICALS AND APPLY IN ACCORDANCE WITH THE MANUFACTURER'S RECOMMENDATIONS.**

# Macadamia pests . . .

## fruit-spotting bug and banana-spotting bug

THE fruit-spotting bug (*Amblypelta nitida* Stal) and the banana-spotting bug (*A. lutescens lutescens* (Distant)) are considered to be the most important pests of macadamia.

Their nymphs and adults feed by piercing and sucking and attacks cause serious premature nut fall and malformation of the kernels.

Feeding on the nuts can occur anytime during the development of the nut, but greatest losses result from attacks on young, soft-shelled nuts during the period October to December. The banana-spotting bug may also cause severe damage to the lush shoots.

### Host plants and distribution

In addition to macadamia, both insects attack a variety of horticultural crops including avocado, custard apples, guava, litchi, passion fruit, pecans and citrus. The fruit-spotting bug also attacks persimmon and is reported from peaches, plums and nectarines as far south as Sydney. *Guioa semiglaucum*, a native found in many south Queensland scrubs is one of its wild hosts.

Wild hosts of the banana-spotting bug are many and include umbrella tree, coffee apple, corky passion vine, white cedar, rough leafed fig, and palay rubber vine. Attacks by both insects are usually more severe in crops surrounded by natural scrub.

In Queensland, the fruit-spotting bug occurs in coastal areas from Rockhampton south, and the banana-spotting bug occurs in coastal areas

north of Buderim. The latter is particularly severe on papaws north of Gympie. Often they both occur together on macadamia.

### Life history and habits

Both insects pass through seven stages, namely, the egg, five nymphal stages and the adult.

- EGGS. The eggs of both insects are oval in shape, about 1.7 mm in length, pale green in colour with a slight opalescence. They are placed singly on the fruit, leaves or terminal branches, and often on the edges of leaves, in crevices or on the petioles of the fruit.
- NYMPHS. The nymphs change from one stage to another by moulting, and slight swellings representing the wing buds are evident at the third stage—becoming larger until the fifth stage. The second last joint of their antennae is black and conspicuously flattened.

The first stage nymphs are pear-shaped, greenish in colour with red to dark red legs and antennae. Later nymphal stages of the two insects can be readily separated. Those of the fruit-spotting bug are orange to greenish with reddish-black legs, antennae and abdomen. The pair of black spots marking the scent gland openings are larger and surrounded by a light red stippled zone.

The nymphs do not move far from their feeding site. They are very alert, however, and tend to escape observation by keeping fruit or leaves between them and the searcher. The first stage nymphs particularly, escape by 'parachuting' if they are disturbed sufficiently.

---

by D. A. IRONSIDE,  
Entomology Branch.

# Macadamia pests . . . fruit-spotting

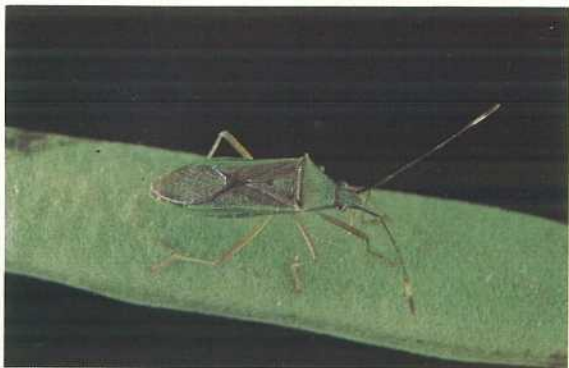

Adult female of fruit-spotting bug (about 15 mm long).



Eggs of the fruit-spotting bug at various stages of development prior to hatching.



Third stage nymph of the fruit spotting bug.



Fifth stage nymph before moulting to become the adult fruit-spotting bug.



Adult female of the banana-spotting bug (about 15 mm long).



Fifth stage nymph before moulting to become the adult banana-spotting bug.

# bug and banana-spotting bug

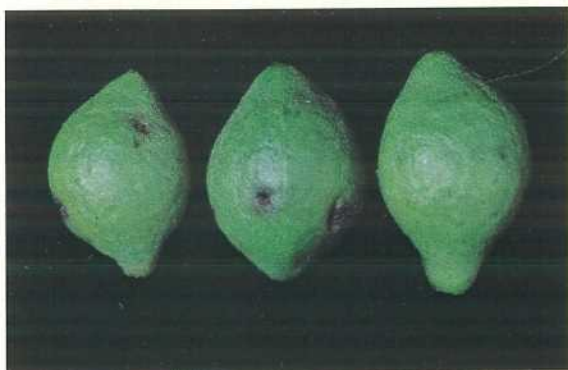

Dark spotting caused by feeding of fruit-spotting bug on nuts 12 mm in diameter.



Sectioned nuts showing brown lesions at feeding points on the inner husk.



Breakdown of the shell and translucency of the kernel caused by bug attack.



Varying degrees of fruit-spotting bug damage to the kernels of harvested nuts.



Fruit-spotting bug damage to the shell. Note the dark brown, sunken spots and the holes in the weakened shells.



Wilting and terminal dieback on young macadamia shoots caused by the banana-spotting bug.

- **ADULTS.** The adults of the two insects are fully winged, slender in build and up to 15 mm long. The fruit-spotting bug is usually a slightly darker green than the banana-spotting bug. Both insects are capable of mating within 5 days of adult emergence and repeated matings are necessary for the continued production of fertile eggs. Adults reared in the laboratory often live for more than 6 months.

The adult female lays only a few eggs each day but as many as 163 eggs have been recorded from a single female over the summer period.

The adults, like the nymphs, do not appear to move far once a feeding site has been selected. It is common to find trees with fruit heavily damaged while adjacent trees are untouched. During the warmer part of the day they fly readily, but usually only for short distances.

- **DURATION OF THE LIFE CYCLE.** During summer, the eggs hatch in 6 to 7 days and the period required for complete development of the fruit-spotting bug from laying of eggs to emergence of adults averages from 34 to 38 days. At 25°C, under laboratory conditions, the average duration for complete development is 45 days for the fruit-spotting bug and 50 days for the banana-spotting bug with an average of 7.5 days and 8 days being required for eggs of the respective bugs to hatch.

Breeding work has indicated that the insects pass through three to four generations each year, one in spring, one to two in summer and one in autumn. The adults of the autumn generation live through the winter and commence egg-laying in spring.

### Damage

It only takes comparatively few insects per tree to cause a lot of damage, particularly while the nuts are small. The banana-spotting bug also attacks the young lush shoots especially in the late summer and autumn after the nuts mature. Feeding by a single female is sufficient to cause the collapse and death of a shoot.

Both insects, while feeding, appear to secrete a toxin, probably an enzyme, which causes the extensive breakdown of the plant cells.

Natural thinning of macadamias can occur anytime during the development of the nut. However, about 2 months after initial set there is usually a noticeably heavy thinning. For most varieties this occurs during the period late October to early December. During this time, most nuts injured by the spotting bugs fall readily—but the older the nuts, the less readily they fall. Feeding during this period can be the cause of most of the kernel damage found in the nuts which mature on the tree.

Often, the first indication of spotting-bug activity is a patchy, heavy fall of green nuts under the tree. The fallen nuts need to be sectioned to determine whether the fall has been caused by natural thinning or by insect attack.

Green, freshly fallen nuts of some varieties, particularly Keauhou (246), show dark, slightly sunken spots on the husk. Cells of the inner husk and soft shell collapse and become discoloured in areas surrounding feeding points. The kernels may be mis-shapen and translucent instead of the normal milky white colour.

In older nuts in which the shell is beginning to harden and turn brown, only small depressions develop on the outer and inner surfaces of the shell or there may be only a pin point mark on the outer surface. Part of the kernel may become brown and shrivelled. On variety Kakea (508), many of the mature kernels can be mis-shapen and shrivelled without any sign of injury on either the husk or the shell.

### Natural enemies

Parasitism and predation is considered unimportant in Queensland in regulating the two species. The assassin bug (*Pristhesancus papuensis* Stal), spiders (*Ocrisiona* sp.), and coastal brown ants (*Pheidole megacephala* (Fabricius)), have been observed preying on fruit-spotting bug. A tachinid, *Pentatomophage bicincta* de Meij., is recorded parasitizing the fifth instar and adult stages of the banana-spotting bug and an unidentified wasp parasite has been recorded from the egg of the same species.

# Safflower variety testing what's happening?

by K. J. JACKSON, Agriculture Branch.

TODAY, safflower production in Queensland is almost entirely concentrated in the central Queensland region with the major production areas confined to the Central Highlands and the Callide-Dawson Valleys.

By far the greatest production is centred within the Capella and Springsure-Orion districts on the Central Highlands.

Varietal testing has formed a major part of the safflower research programme begun by the Department of Primary Industries at the Biloela Research Station in 1954. The variety Gila emerged as the most suitable variety from the initial testing of overseas material obtained mainly from the United States. This variety was grown exclusively in commercial plantings for a number of years.

In conjunction with the rapid expansion of safflower production on the Central Highlands in the early 1960s, Pacific Seeds Australia Pty. Ltd., started a plant breeding programme at Biloela.



*The author checking disease incidence. This is one of the many observations recorded in varietal tests.*

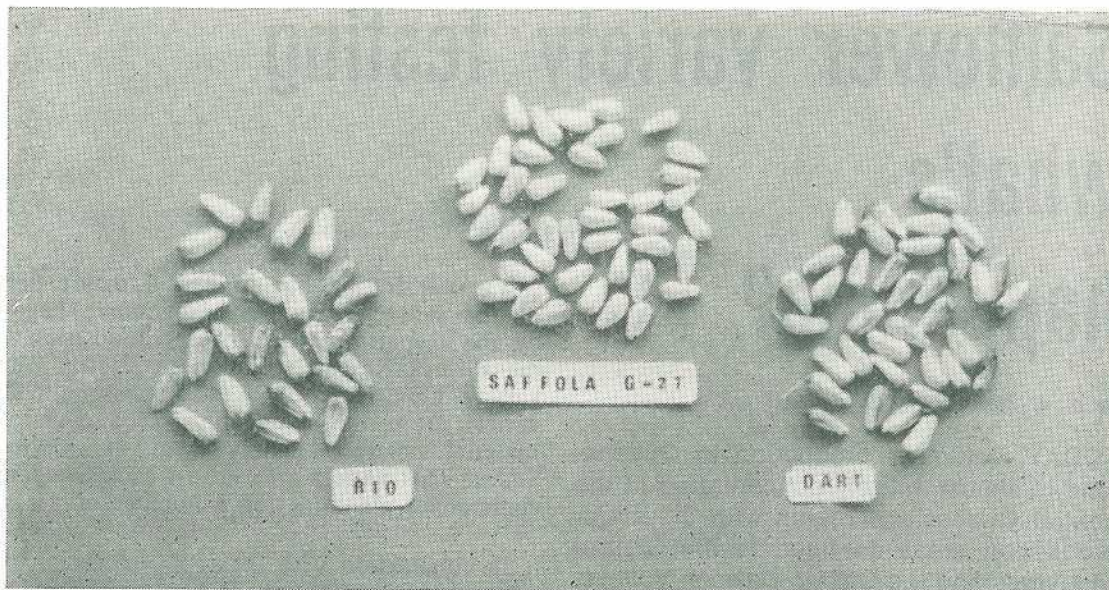

*Seed of the thin-hulled varieties Rio and Dart are larger and darker in colour than the seed of the commercial variety Saffola G-27.*

Varieties from the Pacific Seeds' programme provided most of the material for the Department's continuing variety tests. Two commercial varieties, Saffola G-27 for dryland production and Saffola 208 for irrigated production, were released by Pacific Seeds. Other lines are still being evaluated.

Further material has also been introduced by the D.P.I. and the C.S.I.R.O. from overseas areas particularly the United States, Mexico and Ethiopia.

### **Aims of programme**

As experience with the crop in this region increased, it became evident that varietal selection should be based primarily on increased earliness, cold tolerance, oil content and disease resistance.

For dryland production, the ultimate objective is to select a variety with a growing season approximately that of wheat while maintaining acceptable levels of oil yield and disease resistance.

### **Testing procedures and locations**

Until 1972, varietal testing was virtually confined to the Biloela Research Station. Since 1973, trials have been grown each year at both Biloela and Emerald. Trials were also grown on sites at the Brigalow Research Station near Theodore in 1974 and 1975, and at Capella and Fernlees on the Central Highlands in 1975.

All varieties available in 1973 were tested under dryland conditions at Biloela and under irrigation at Emerald. Detailed measurements of yield, oil content, volumetric weight, 1000 grain weight, flowering and maturity dates as well as disease ratings were recorded for each variety. They were compared with the standard commercial varieties Gila and Saffola G-27 in the dryland trial, and with Gila and Saffola 208 in the irrigated trial. On the basis of these comparisons, varieties were selected for further testing at the sites described above.



TABLE 1 (a)  
DRYLAND SAFFLOWER SEED YIELD MEANS (kg per ha)

Variety	Biloela R.S. 1973-75	Brigalow R.S. 1974-75	Capella 1975	Fernlees 1975	Variety mean
Rio .. .. .	880	1 126	693	662	892
Saffola 2-47 .. .. .	910	1 028	851	575	887
Saffola 208 .. .. .	927	971	782	585	870
Saffola G-27 .. .. .	813	940	817	666	829
Gila .. .. .	907	896	785	586	840
Dart .. .. .	737	1 036	725	607	802
Leeds .. .. .	703	932	682	648	757
Site mean yield* .. .. .	801	963	739	606	..

\* Site mean yield is the mean of all the varieties in the trial at each site.

TABLE 1 (b)  
IRRIGATED SAFFLOWER SEED YIELD MEANS (kg per ha)

Variety	Emerald			Variety mean
	1973	1974	1975	
Rio .. .. .	2 003	1 344	1 117	1 418 (3 yr.)
Dart .. .. .	1 710	887	†	1 298 (2 yr.)
Saffola 208 .. .. .	1 855	945	1 079	1 293 (3 yr.)
Gila .. .. .	1 940	574	1 346	1 286 (3 yr.)
Saffola G-27 .. .. .	1 564	746	†	1 155 (2 yr.)
Leeds .. .. .	1 574	995	895	1 154 (3 yr.)
Saffola 2-47 .. .. .	†	1 205	991	1 098 (2 yr.)
Trial mean yield* .. .. .	1 715	915	1 086	..

\* Trial mean yield is the mean of all the varieties included in the trial for each particular year.

† Variety not included in the trial.

### Trial results

Yield results of the top seven varieties tested are presented in table 1 (a) for dryland trials and table 1 (b) for irrigated trials. Average oil content percentage and volumetric weights for the same varieties are included in table 2 (a) for dry land trials and table 2 (b) for irrigated trials.

Winter rainfall in 1973 and spring rainfall in 1974 and 1975 were above average. Climatic conditions in 1974 and 1975 were very favourable for the development of the disease *Alternaria carthami* which severely affected the trials at Biloela and Emerald. This is indicated

in table 2 (a) and table 2 (b) by the abnormally low oil contents and volumetric weights recorded.

In the dryland trials, no variety consistently outyielded the current commercial varieties Gila and Saffola G-27.

Although Saffola G-27 had a lower mean yield over all trials, its yield did not vary from trial to trial as much as that of Gila.

Similarly, Saffola 208 the recommended variety for irrigation, was not significantly outyielded in the irrigated trials. The variety Rio which produced the highest yields in all three irrigated trials would be a worthy alternative variety.

TABLE 2 (a)  
OIL CONTENT AND VOLUMETRIC WEIGHT MEANS FOR DRYLAND SITES

Variety	Oil content (%)					Volumetric weight (kg per hl)				
	Biloela R.S. 1973-75	Brigalow R.S. 1973-74	Capella 1975	Fernlees 1975	Variety mean	Biloela R.S. 1973-75	Brigalow R. 1974-75	Capella 1975	Fernlees 1975	Variety mean
Saffola 2-47 .. ..	30.8	34.9	34.8	32.5	32.79	42.9	50.0	55.8	51.3	47.99
Leeds .. .. .	29.0	34.0	35.9	33.3	32.03	40.7	50.7	55.8	52.4	47.40
Saffola 208 .. ..	29.4	33.8	35.2	32.6	31.93	41.7	48.9	55.3	50.5	46.97
Dart .. .. .	26.6	33.8	36.1	36.0	31.37	41.0	46.9	53.6	49.2	45.67
Rio .. .. .	29.0	32.4	34.6	32.4	31.27	41.5	48.3	53.9	50.6	46.51
Saffola G-27 .. ..	28.8	32.6	34.0	30.2	30.80	41.1	48.2	52.9	47.1	45.66
Gila .. .. .	27.0	32.4	34.2	29.9	29.99	42.7	48.8	54.3	45.9	46.54
Site mean .. ..	28.5	32.2	34.2	31.4	..	41.7	48.8	54.2	49.6	..

TABLE 2 (b)  
OIL CONTENT AND VOLUMETRIC WEIGHT MEANS FOR IRRIGATED SITES \*

Variety	Oil content (%)				Volumetric weight (kg per hl)			
	1973	1974	1975	Variety mean	1973	1974	1975	Variety mean
Dart .. .. .	35.1	32.1	†	33.6 (2 yr.)	48.5	40.1	†	44.3 (2 yr.)
Saffola G-27 .. ..	34.1	29.3	†	31.7 (2 yr.)	48.6	40.0	†	44.3 (2 yr.)
Saffola 208 .. ..	34.8	31.4	26.4	30.9 (3 yr.)	50.6	43.2	41.3	45.0 (3 yr.)
Rio .. .. .	35.3	30.9	25.8	30.7 (3 yr.)	49.5	40.9	41.2	43.9 (3 yr.)
Leeds .. .. .	34.3	31.7	24.9	30.3 (3 yr.)	49.3	42.4	40.7	44.1 (3 yr.)
Gila .. .. .	34.5	27.5	26.9	29.6 (3 yr.)	51.7	38.8	42.3	44.3 (3 yr.)
Saffola 2-47 .. ..	†	32.7	26.2	29.5 (2 yr.)	†	44.6	41.1	42.9 (2 yr.)
Trial mean .. ..	34.8	29.6	25.3	..	48.9	41.6	41.5	..

\* Oil percentages and volumetric weights calculated on grain moisture percentage of 8 %.

† Variety not included in the trial.

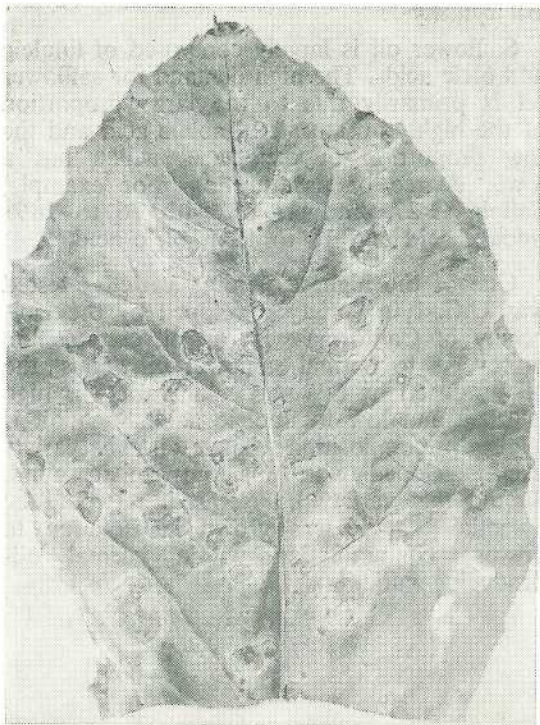

Safflower leaf showing a severe infection by the disease *Alternaria carthami*. Note the concentric rings within the lesion—these give the name of 'target spot'.



Lesions of the leaf disease *Alternaria carthami* eventually result in complete destruction of the leaf.

Overall, there were very few differences among the varieties tested. The following discussion describes the major recorded variations.

### Disease resistance

- **ALTERNARIA** leaf blight. The leaf, stem, and head blight, *Alternaria carthami*, which was first recorded in Queensland late in 1972 has become the most serious disease affecting safflower in the region.

By 1975, the disease was widespread and favourable weather conditions for its development resulted in substantial yield reduction in trials as well as in the majority of commercial crops.

All varieties that have been tested are susceptible. The greatest degree of resistance has been observed in the Ethiopian variety, Aklilou. Unfortunately, this variety is approximately 8% lower than Gila in oil content. Other varieties to show some degree of resistance were the selections of Saffola 208 which included Saffola 2-47, Saffola 2-3 and Saffola 2-30. The current commercial varieties Gila and Saffola G-27 are particularly susceptible.

- **PHYTOPHTHORA** root rot. Until 1973, the major disease affecting safflower in this region was the root rot caused by *Phytophthora drechsleri*. This disease presents problems in poorly drained areas of dryland crops such as gilgaied or melon hole areas in cleared brigalow land. In irrigated crops, losses from the disease may occur if correct furrow levels are not maintained. No occurrence of the disease was noted in any of the varieties tested at Emerald provided that ponding in furrows was avoided and plants were not stressed before irrigating.

### Earliness

Time to flowering in the majority of varieties tested was either similar to or longer than that recorded for Gila. However, two experimental lines developed by Pacific Seeds demonstrated an advancement in maturity of one week over Saffola G-27 which is approximately a week earlier than Gila. Unfortunately, these experimental lines were inferior to Gila in oil content, yield and disease resistance.

## Oil content

A number of introductions made from the United States including the varieties Dart, Rio and Frio were released in the United States as thin-hulled, high oil content varieties. The thin-hulled characteristic which is associated with high oil content is denoted by a light brown seed coat marked by distinct dark brown stripes. These varieties have produced significantly higher oil contents than Gila in the United States, but have not performed as well here. Negligible differences have been recorded between the oil contents of these varieties and Gila in the central Queensland trials.

The varieties producing the highest oil contents in the trials have been selections of Saffola 208. Of these, Saffola 2-47 has consistently produced the highest oil content. In some trials, it has been as high as 41% on a moisture free basis.

## Oil quality

Safflower oil is largely composed of linoleic and oleic acids. The high demand for safflower oil is primarily due to the large proportion of the highly unsaturated linoleic acid and the low proportion of oleic acid which has a lower degree of unsaturation. For example, Saffola G-27 produces oil with 76 to 78% linoleic acid and 10 to 12% oleic acid.

One of the highest yielding varieties tested was U.C.-1, a variety developed by the University of California with an oil composition in reverse to normal safflower oil. Thus, the oil produced by this particular variety is high in oleic and low in linoleic acid. Such oil is similar in composition to olive oil. The variety was developed with this purpose in mind. Should this variety be released, it would be essential that it was grown in isolation to prevent contamination within normal oil-producing varieties.



*Safflower at peak flowering. Little variation occurred within the varieties tested for the time taken to reach this stage.*

## Future programme

As a result of the devastating effect of the disease *Alternaria*, the testing programme will concentrate on screening all available material for resistance to this disease. Evaluation of crosses made at the Biloela Research Station between lines that show a degree of resistance to the disease as well as evaluation of introduced material will be carried out.

If tolerant or resistant varieties can be developed or isolated, testing will be resumed in the major production areas. Until this stage is reached, irrigated production involves a high risk because the humid conditions created within the crop canopy by irrigation favour the rapid development of *Alternaria*.

Dryland production, especially large areas, must also be contemplated with caution as there is no suitable variety available that can

escape a severe outbreak of the disease as occurred in central Queensland in 1975. The disease may present little problem in dryland production in a season with low rainfall between July and November. However, should wet conditions develop during this period, some loss from this disease is very likely to occur.

## Acknowledgements

The author wishes to thank the co-operators, Mr J. White of Capella and Mr J. Braitling of Fernlees, and the Research Station managers for providing land.

The following officers of the Department of Primary Industries provided valuable assistance: Messrs E. S. Uridge, R. G. H. Nielsen, C. A. Ladewig and J. D. Churchett.

---

# Brand returns

Did you know that:

- The brand return and stock return you have been submitting are two entirely different returns required by different Acts of Parliament and used by different sections of the Department of Primary Industries?
- Brand returns are still required and should be submitted on January 1 each and every year?
- There is no fee associated with a brand return?
- If a brand return is not submitted for three consecutive years, your brand can be cancelled under Section 18 of the Brands Act, 1915-1975?

For further information on brand returns contact:

**The Registrar of Brands,  
Department of Primary Industries,  
William St.,  
Brisbane. 4000.**

# New fertilizer distributor

by P. E. Page, Horticulture Branch.

D.P.I. officers have built a prototype improved fertilizer distributor which can supply nitrogen, phosphorus and potash separately and at independently variable rates.

This machine has been developed co-operatively by officers of the Redlands Horticultural Research Station and the Agricultural Engineering Development Unit in Toowoomba.

This new-style fertilizer distributor which will reduce fertilizing costs can place fertilizer at two positions within the one plant row. It also has other technical advantages.

A commercial three hopper fertilizer distributor has been modified so that a separate gear train operates each hopper. The three separate hoppers are used to apply nitrogen, phosphorus and potassium separately, and the gearing is such that a wide range of application rates can be used for each nutrient.



The distributor displayed at a recent field day.

# ... a cost saver

Two smaller hoppers are used to either apply a second or 'starter' band in each row or, alternatively, may be used for the application of trace elements. A delivery point from each side of the hoppers allows two separate rows to be fertilized at the one time or combined to apply fertilizer to a single row.

## Advantages

The advantages of the new distributor are:

- LOWER FERTILIZER COSTS. The distributor uses straight nitrogen, phosphorus and

potash fertilizers such as urea, superphosphate and muriate of potash, instead of mixtures. This results in an immediate cost saving because NPK mixtures are dearer than an equivalent amount of fertilizer applied as straight nitrogen, phosphorus and potash fertilizer.

This saving is approximately 30% for a 12:14:10 NPK type mixture. If the N, P and K are applied separately, a further cost saving is possible if the amount of any nutrient can be reduced because a soil analysis shows it is adequate.

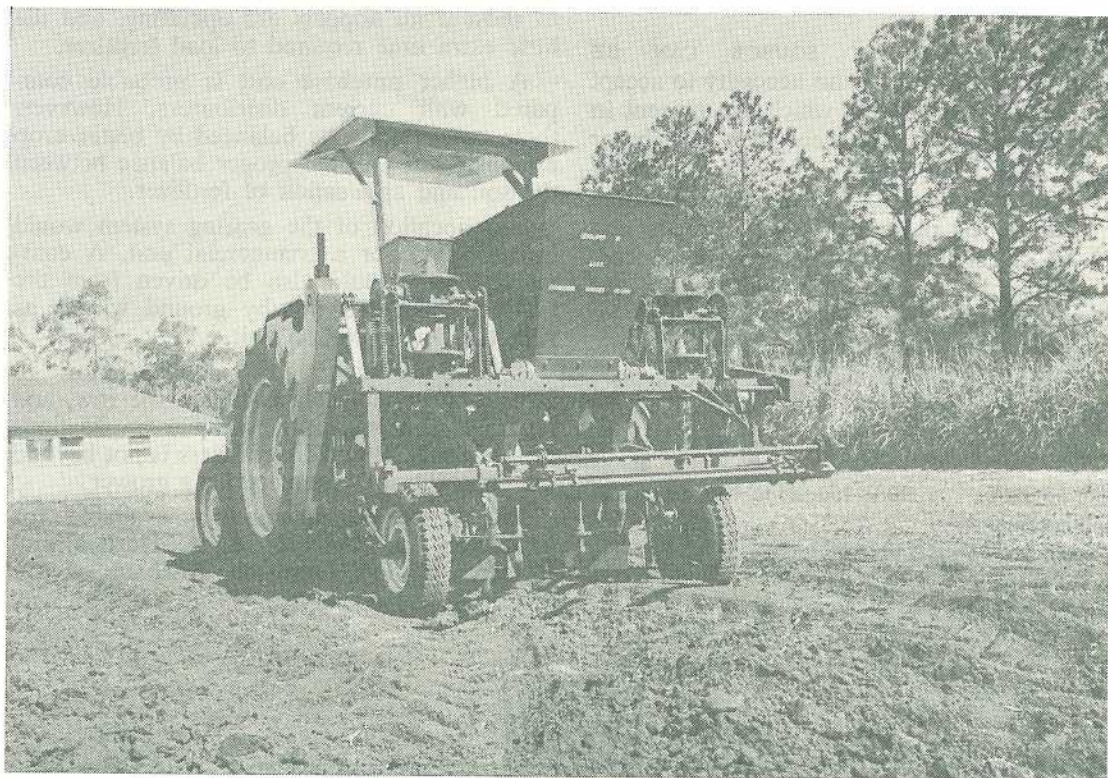

*The distributor mounted on a tractor at the Redlands Horticultural Research Station.*

- **DOUBLE PLACEMENT WITHIN THE ROW.** The ability of the distributor to place fertilizer at two positions within the plant row, that is, a starter application plus a basal band, has important advantages in many direct-seeded and transplanted vegetable crops. Tomato plants, which have a poor ability to forage for nutrients when small, are particularly responsive to starter fertilizer applications.
- **APPLICATION OF TRACE ELEMENTS.** The two additional hoppers on the distributor may be used to apply essential nutrients other than N, P and K when they are not required for starter band applications. Sulphur, manganese, zinc, copper and molybdenum could be applied through the additional hoppers. Very low rates of trace elements must be used if being banded, and care is necessary to avoid applying toxic quantities.
- **CORRECT NUTRIENT SOURCE CAN BE SELECTED.** There is no necessity to accept the nutrient sources which are present in mixtures when the new style distributor is used. Therefore, either urea, nitram, sulphate of ammonia, calcium ammonium nitrate, or di-ammonium phosphate can be selected to suit the nitrogen need. Similar choices are available for phosphorus and potassium.

### Current capabilities

	output kg per ha		
	N	P	K
Major hoppers ..	10 to 160	25 to 400	15 to 230
Small hoppers—			
urea ..	10 to 80		
D.A.P. ..	4 to 19	4 to 20	

### Comparative costs

(i) 12-14-10 type mixture. Cost \$200 a tonne.

1 tonne contains 120 kg of N  
140 kg of P  
100 kg of K

To supply these quantities using urea + superphosphate + muriate of potash as straight fertilizers, the costs are \$146. Thus, the mixture costs 36% more.

(ii) 5-6-4 type mixture. Cost \$102 a tonne.

1 tonne contains 50 kg of N  
60 kg of P  
40 kg of K

Again, to supply these quantities using urea + superphosphate + muriate of potash the costs are \$64. The mixture therefore costs 59% more. The use of other sources of N and K slightly increases the cost of application of straight fertilizers.

Further costs may be involved in machine maintenance, the purchase of a warning system to show if all hoppers are operating, and the little extra time required to load fertilizer.

A higher purchase cost is probable compared with current distributors. However, these costs should be balanced by better crop establishment and the proper balance between the soil and application of fertilizer.

Simplification of the gearing system would be necessary for a commercial unit. A commercial unit would also be driven from the tractor wheel and not by ground wheels as with the demonstration unit.

The construction of a distributor to incorporate double placement in the row, and separate, independently variable applications of straight N, P and K fertilizers is not beyond the capability of an enterprising grower.

The prototype machine is available for inspection at the Redlands Horticultural Research Station, Ormiston, Brisbane.





# Home ram breeding

THE aim of a home ram breeding project is to produce at a cheaper cost rams of comparable or better quality than purchased rams.

## Prerequisites

### Property qualifications

The property must be suited to sheep breeding and growing.

### Manager qualifications

The manager must appreciate that any breeding programme is a long term project and necessitates extra work and management decisions. The manager must be keen and well organized.

### Flock standard

The ewes to be used in the ram breeding flock must be equal to the average stud ewes of the district. If the flock is not as good as the average stud ewes any gains made by ram breeding will be less than those obtained from purchased rams.

### Facilities

Some paddocks adjacent to the shearing shed yards are required. These are used for year-round management and selected joining of top rams to top ewes. More small paddocks are essential if progeny testing is undertaken.

### Size of breeding flock

To be economical, the ram breeding flock should be readily incorporated into existing

by D. M. ALLISON and D. J. JORDAN,  
*Sheep and Wool Branch.*

facilities. If additional fencing, water points and yards have to be provided the cost of producing rams may exceed the benefits and savings obtained.

## Principles Involved

The main factor affecting gross wool return is clean fleece weight. Clean fleece weight is determined by fibre density, fibre length and skin area. Selection is based on clean fleece weight.

The main determinant of skin area is body size. A sheep with good body length, breadth and depth has a large skin area.

The other determinant of skin area is the degree of skin wrinkling, but wrinkly sheep are more subject to flystrike and more difficult to shear.

Sheep with excessive body wrinkles, muffled faces, breeding and conformation faults (for example, devil's grip, bad backs, etc.) are automatically culled.

After the 'off-type' sheep are culled, the remainder are fleece weighed. Fleece weighing ensures the accuracy of the selection procedure. As rams have a greater influence on the genetic progress than ewes, they undergo more testing than ewes.

## Rams

Having a large number of ram lambs from which to select is one of the secrets to success in ram selection. Because only a small percentage of the ram lambs dropped are required, only a few of the best producers have to be selected. Ram lambs of undesirable type are castrated at lamb marking or weaning.

All the rams are identified and at shearing their fleece is weighed and a mid-side sample of approximately 100 grams (4 ounces) is taken. This sample is tested at a laboratory for yield and fibre diameter. The clean fleece weight is calculated from the greasy fleece weight and yield.

The average clean fleece weight is then calculated and the rams can be ranked in order of merit.

The average fibre diameter for each ram is calculated by the laboratory.

The top sires are selected from the rams which cut the highest clean fleece weight and are within the desired fibre diameter range. As fibre diameter varies with seasonal conditions the actual diameter selected will vary from year to year. In most cases, the rams selected have average fibre diameters which lie within 1 micron of the average fibre diameter of that group of rams.

Restricting the selection of rams close to or finer than the average fibre diameter means that the extra weight obtained comes from fibre length, more fibres or greater skin area and not increased fibre diameter.

The stronger wools (that is, thicker fibre diameter wools) suffer a price penalty but the advantage of extra weight can offset the lower price. Excessively fine-wooled sheep more readily suffer a break in fleece (tender wool) under poor nutritional and drought conditions. Tender wool is penalized in the sale room.

The top selected two-tooth rams are used in the nucleus flock. The next highest cutting group is joined to the general flock ewes. If selection is accurate and improvement is taking place, two-tooth rams should be better than the average of the older group of rams. Therefore, the higher the proportion of two-tooth rams in the ram flock, the faster the improvement. A suggested composition of the ram flock is 33% each of two-tooth and four-tooth rams and the remaining 33% comprising the best of the older rams.

### **Ewes**

In most of the breeding programmes about 33% of the older ewes are culled each year and replaced by the top cutting two-tooth ewes.

### **Problem of inbreeding**

Because of the large number of ewes and rams in the ram breeding flock, inbreeding is rarely a problem. It mostly occurs where there has been heavy use of the progeny of one particular sire in the breeding programme. Inbreeding occurs faster in a small nucleus flock, and advice from a geneticist should be sought if this is suspected.

### **Practical ram breeding principles**

The above principles have been used by a number of stud and non-registered ram breeders.

The number of ewes and rams used varies from flock to flock depending on the breeder's own requirements and whether or not he offers rams for sale. Flocks of between 400 and 1 000 ewes are common and in flocks of this size inbreeding is not likely to be a problem for many years.

After their initial success, some home breeders have registered as stud breeders and continue to breed rams on these principles.

### **Conclusion**

Home ram breeding flocks can be successfully developed to produce top quality sheep. It is important that the ewe and ram flocks are of a high standard, the breeder keen, capable and well organized, the country is sheep breeding country and the necessary facilities are available.

Selection must be based on visual selection, fleece weighing and measurement. This maintains a high efficiency in selection of top producing sheep.

---

## **Use of symbol brands and earmarks**

- An earmark may only be used on a beast which already bears a three piece or symbol brand.
- A symbol brand must be registered in conjunction with a three piece brand. However, either may be used alone to denote ownership.

# Sunflower growing —a changing industry

by N. E. Delaney, Agriculture Branch.

THE introduction of oilseed sunflowers into Queensland at a time of strong market demand for vegetable oils and the introduction of wheat quotas caused a rapid expansion in sunflower growing in the early 1970s.

Sunflower production had previously been restricted to supplying the limited and unpredictable birdseed market.

Tables 1 and 2 indicate sunflower production trends in Queensland. The three major sunflower districts have accounted for 88 to

96% of the State's annual production for the years recorded in the tables. The Darling Downs produced more than half the State's sunflowers until 1973-74 but now the Central Highlands is a more important production area.

Oilseed sunflowers performed spectacularly in the first season of extensive plantings in the Darling Downs. Crops were planted with excellent soil moisture reserves but little or no effective rain fell during the growing period.

Grain sorghum crops produced poorly with many failing completely while most sunflower



*Hysun 30 was one of the first hybrid sunflower varieties introduced to Queensland. Even height and uniform maturity together with rust resistance have been the main advantages of these first hybrids.*

TABLE 1  
QUEENSLAND SUNFLOWER PRODUCTION BY MAJOR PRODUCING DISTRICTS

Year	Area (ha)				Production (tonnes)			
	A*	B*	C*	D*	A	B	C	D
1954-55 .. ..	2 389	23	23	2 798	1 542	..	20	1 754
1959-60 .. ..	2 317	265	36	2 711	1 760	116	19	1 958
1964-65 .. ..	3 872	426	..	4 311	2 289	145	..	2 443
1969-70 .. ..	12 892	360	1 302	15 581	5 501	57	282	6 297
1970-71 .. ..	16 599	895	1 537	10 086	12 028	446	1 096	14 193
1971-72 .. ..	37 036	5 183	6 994	53 676	16 763	3 467	1 980	23 965
1972-73 .. ..	50 416	17 761	4 269	80 119	33 231	8 455	1 898	45 428
1973-74 .. ..	36 947	23 067	4 379	67 487	22 577	16 924	1 972	43 189
1974-75 .. ..	27 999	56 588	12 896	104 923	19 282	36 320	6 463	68 402
1975-76 .. ..	21 442	32 838	2 473	62 393	13 803	18 952	1 614	38 197

\*A—Darling Downs statistical division.

\*B—Central Highlands—Shires of Belyando, Peak Downs, Emerald and Bauhinia.

\*C—Callide Dawson—Shires of Banana and Duaringa.

\*D—Queensland total.

Source: Australian Bureau of Statistics.

TABLE 2  
QUEENSLAND SUNFLOWER YIELDS AND NUMBER OF GROWERS BY MAJOR PRODUCING DISTRICTS

Year	Yield (kg/ha)				Number of Growers			
	A*	B*	C*	D*	A	B	C	D
1954-55 .. ..	646	..	..	627	..	..	..	..
1959-60 .. ..	760	438	..	722	..	..	..	..
1964-65 .. ..	591	341	..	567	..	not available	..	..
1969-70 .. ..	427	159	216	404	..	..	..	..
1970-71 .. ..	725	498	713	707	..	..	..	..
1971-72 .. ..	453	669	283	446	678	44	88	856
1972-73 .. ..	659	476	445	567	998	110	55	1 246
1973-74 .. ..	611	734	450	640	777	137	54	1 042
1974-75 .. ..	689	681	501	652	611	239	151	1 198
1975-76 .. ..	644	577	653	612	518	189	35	991

\* Districts as for Table 1.

Source: Australian Bureau of Statistics.

crops. The superior sunflower performance was due to its earlier maturity and ability to use soil moisture from considerably greater depths than sorghum.

The crop has limited application in the wetter agricultural areas such as the South Burnett and coastal regions. Likewise, there is limited potential for irrigated sunflower production. There will however, always be some interest in sunflowers for high rainfall and irrigation areas due to their frost tolerance and short growing period. These two characteristics allow the crop to be grown when other crops are impractical.

The future of the Queensland sunflower industry will be mainly determined by market prospects and varietal improvement. Any

expansion will be in the extensive areas where grain sorghum and winter cereals are the main alternatives.

At present, sunflower yields are about one-third those of grain sorghum. Hence, it is only when sunflower prices approach three times the on-farm price of grain sorghum that they become more profitable. Varietal improvement may improve this ratio and make sunflowers a more attractive crop financially.

The first hybrid sunflowers introduced into Australia have shown little if any yield advantage over open pollinated varieties in most situations. They are, however, rust resistant. Some recent trials have produced more promising results from new hybrids.



*Sunflowers are a potential weed of subsequent crops. Careless harvesting accentuates the problem as shown here.*

The sunflower is considered an inefficient plant because it has a low harvest index. This means that the weight of seed produced is a lower proportion of the total plant weight than for most other crops. Despite this disadvantage, sunflowers deserve a place in our agriculture for the high quality oil they supply. Vegetable oil prices are fairly closely linked but sunflower oil commands a premium for its higher quality.

### **Varieties and breeding**

Higher yielding varieties would considerably improve the longer term prospects for the local sunflower industry. Spectacular increases in yield and oil percentage through breeding have been reported from Russia and Rumania.

Experience suggests that those varieties would be lower yielding here and that we will have to depend mainly on Australian sun-

flower breeding efforts to produce varieties with broad adaptation. The main aim of plant breeding in sunflowers is obviously higher yields but other characteristics such as oil content, oil quality and disease resistance are also important breeding objectives.

An adequate insect population is necessary to provide the cross pollination necessary for seed set in sunflowers. Reduced seed set in wet weather has been attributed to reduced bee activity. Hybrids have been selected for increased self compatibility. Research work has shown that normal insect levels on the Darling Downs are adequate for sunflower pollination.

The oilseed sunflower varieties presently available in Queensland show little difference in yield and agronomic performance. However, the hybrids are more uniform in flowering, height and head size, and exhibit a resistance to rust which is desirable for later plantings in the more humid areas.

The bird-seed variety, Polestar, yields similarly to the open pollinated oil-seed varieties. This seed is easily distinguished from the black oilseed types by the light stripes on its seed coat.

### Where to plant

Sunflowers should only be planted into a deep soil, wet to at least 1 metre unless average annual rainfall exceeds 750 mm or irrigation is available. Sunflowers are resistant to frosts in the seedling stage and also at maturity. They can be grown earlier or later than other summer crops.

This can spread the farm labour requirements and justify planting even if the potential return is less than for other summer crops. This frost resistance, together with quick maturity, and rapid stubble breakdown also make the crop attractive for double cropping and opportunity cropping systems.

Sunflowers often leave the soil in a good tilth for succeeding crops but on some heavy soils it can take a long time to replenish the subsoil moisture removed by sunflowers. This has often limited the yields of the following crops. Bird damage can be extremely serious, especially if trees are located near the crops. This problem has virtually stopped sunflower production in some districts.

The crop should not be planted where weeds cannot be adequately controlled by inter-row cultivation as there are no herbicides available for post emergence use. Trifluralin can be used as a pre-emergence herbicide but the cost restricts its use in sunflowers. The crop is very sensitive to hormone-type herbicides and considerable care is needed to ensure that none drift on to the crop.

The crop itself is a potential weed of subsequent crops although care when harvesting can reduce the problem. Self-sown sunflowers often need to be sprayed with 2,4-D in subsequent winter cereal crops. This characteristic deters many farmers from growing the crop.

### Fertilizer requirements

The present sunflower varieties have often shown little response to fertilizer in situations where other crops have responded well. On other occasions, the crop has responded well to fertilizer application. One explanation of



*Seed set commences at the outer edge of the head and continues steadily towards the centre.*

this behaviour is the difference in crop root systems and the consequently deeper soil exploitation by sunflowers.

While soil testing is a useful guide in making fertilizer recommendations, caution in interpretation is warranted when sunflowers are grown. Local experience of sunflower response to fertilizer is the best guide to soil test interpretation. Where this is not available, about 12 kg phosphorus per ha should be tried on deficient soils. It is preferable that phosphate fertilizer be banded with or near the seed. Nitrogen rates vary widely according to conditions but generally are less than for other crops. Nitrogenous fertilizers should not be placed in contact with the seed.

Other nutrient disorders are not often recognised in Queensland but the crop is highly susceptible to boron deficiency. Sunflowers seem less sensitive to zinc deficiency

than many other crops but this deficiency can cause considerable yield reduction without obvious symptoms other than reduced growth and delayed flowering.

Manganese toxicity has been confirmed at Camden in New South Wales but not in Queensland. Potassium deficiency could be expected in very deficient soils.

### Planting time

In southern Queensland, sunflowers are planted from late August until October and from late December until early March. The

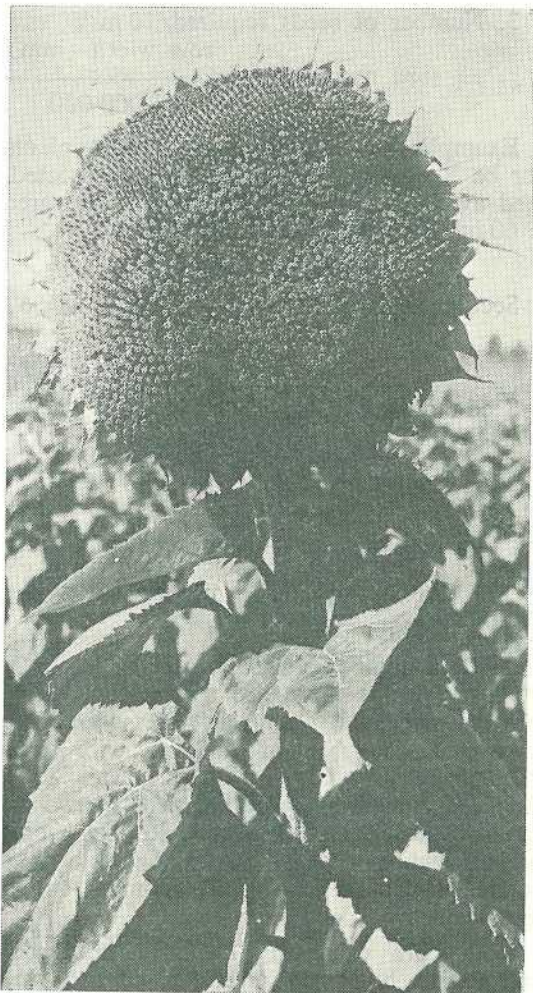

*Seed fill is well under way in the outer part of the head before seed set is complete in the centre. The centre may fail to set seed in dry conditions.*



*Large sunflower heads can look impressive but the optimum head size is about 15 cm in diameter.*

earlier plantings tend to produce higher yields but lower seed oil percentage and poorer oil quality.

These earlier plantings are more likely to experience difficult harvesting conditions—either too wet or too hot and dry. November plantings are not encouraged as they are likely to encounter very difficult growing conditions.

In some years, good results have been obtained from abnormal planting times due to unusual seasonal conditions. Individual crop performance is very dependent on actual temperatures and soil moisture, whereas recommended planting times are based on expected seasonal conditions. In Central Queensland, the crop is sown from late December until early March.

### Seed placement

Both local and overseas experience has shown that sunflowers are extremely susceptible to uneven plant spacings.

It is very difficult to achieve even plant spacing in sunflower crops sown with a combine. If a combine is used to plant sunflowers, use every second run of the machine which gives about 35 cm row spacings. Small seed is preferable for planting through a combine as the larger grades are difficult to plant.

Sunflower seed is a difficult seed to mechanically handle for precision planting. Reasonable results are possible when using well-graded seed in an inclined plate-type planter but the recently introduced air planters are the best type currently available for sunflower planting. Modern row crop planters achieve precision in both planting depth and seed placement better than combines which mostly tend to scatter the seed through much of the cultivated layer of soil.

The optimum is to place the seed at about 5 cm depth on to a firm, moist soil with the cultivated top soil lightly pressed by a press wheel or roller. Sunflowers will not tolerate deep planting and should not usually be planted deeper than 7 cm, the smaller grades of seed being particularly susceptible.

### Plant populations

A number of experiments have been conducted in Queensland to determine optimum sunflower populations. Recommendations vary from about 30 000 plants per ha in the drier areas to around 60 000 planted per ha for the best dryland conditions. 100 000 plants per ha are recommended for fully irrigated crops.

Head size is a good indicator of population suitability to that season in evenly spaced crops. Head diameters of less than 10 cm suggest either a below average season or too thick a population because they are usually caused by a fairly severe moisture stress. Head diameters in excess of 20 cm in an even crop suggest that a higher population could have been used to advantage. These larger heads are much more difficult to harvest than those about 15 cm in diameter. Uneven plant distribution causes a wide range of head sizes and uneven crop maturity.

Seeding rates need to be above the desired plant populations. Under most conditions, a 70 to 75% establishment can be expected. It is unusual to get much above 50% establishment when planting sunflowers into a heavy soil with a combine.

Current commercial seed grades run from 13 000 to 26 000 seeds per kg. The following three formulae can be used to estimate seed requirements and to check seeding rates.

$$1. \text{ Seed number/ha} = \frac{\text{desired plant population/ha} \times 100}{\text{expected germination percentage}}$$

$$2. \text{ Seed required (kg)} = \frac{\text{seed number/ha} \times \text{area to be planted (ha)}}{\text{seed number/kg}}$$

$$3. \text{ Number of seeds required/10 m of row} = \frac{\text{row width (mm)}}{1000000} \times \text{seed number/ha}$$

Example: A population of 50 000 plants per ha is desired, 75% germination expected, seed available has 20 000 seeds per kg, area is 60 ha and row width is 300 mm.

$$\text{Seed number/ha} = \frac{50\,000 \times 100}{75} = 66\,667$$

$$\text{Seed required} = \frac{66\,667 \times 60}{20\,000} = 200 \text{ kg}$$

$$\text{Number of seeds required/10 m row} = \frac{66\,667 \times 300}{1\,000\,000} = 20$$

### Insect pests

While a number of insects may be found in sunflower crops there are few circumstances where chemical control measures are warranted. If a problem with false wireworms is anticipated, an application of insecticide in the seed furrow is recommended. Cutworms can also cause severe damage to seedling crops. An application of 550 g per ha of trichlorphon is recommended for their control when significant crop damage is seen.

Both corn earworm (*Heliothis armigera*) and native budworm (*Heliothis punctigera*) are common in sunflowers, initially feeding mainly on foliage and then on the backs of the sunflower heads. They usually do little feed-



ing on the seeds and do not defoliate the plants sufficiently to affect yields. By feeding on the backs of the sunflower heads they do allow later development of head rots but insect control to reduce head rot development substantially seems impractical.

Green vegetable bug (*Nezara viridula*) is considered a pest of sunflowers overseas but is not a significant pest of sunflowers in Queensland.

Rutherglen bug (*Nysius vinitor*) is a sporadically serious pest of sunflowers in Australia, and again control measures are rarely justified because of their ineffectiveness. Serious infestations are usually associated with dry weather and a good general rain usually results in their disappearance.

If insecticides are used in sunflower crops, care should be taken that no commercial bees are in the vicinity, or that they are at least confined to their hives. Spraying in the late afternoon could minimize the damage to native

bee populations. Indiscriminate spraying will reduce sunflower yields because of the crop's dependence on insects for pollination.

Sunflower seed has been attacked in storage by Indian meal moth (*Plodia interpunctella*), tropical warehouse moth (*Ephesia cautella*) and rust red flour beetle (*Tribolium castaneum*). Cleaning of harvesting, handling and storage facilities is as essential for sunflowers as for other grain and oilseed crops.

## Diseases

A good general disease control measure is to rotate sunflowers with gramineous crops. Legume crop rotations are less effective because they are alternate hosts for some sunflower diseases. Such rotations can cause serious disease problems in both the legume and sunflower crops. Disease problems are aggravated if sunflowers are planted immediately after sunflowers.



As the sunflower matures, the stem bends over and the head curves back at the rim. Head rot can spread rapidly from infections in the exposed back of the head after this stage in humid conditions.

Rust is probably the most important sunflower disease in Queensland. It can reduce yields by more than 50%. It has attracted the attention of plant breeders and a form of rust resistance has been bred into some local varieties. The resistance is of single gene type that is likely to be over-come by the rust and attention is now being directed towards a more reliable multi-genic resistance.

Rust is not a problem with early plantings but later plantings can be seriously affected. Increased plantings of sunflowers could be expected to increase the seriousness of the disease later in the season unless resistant varieties are used. In areas such as the Central Highlands and the Western Downs, the incidence of rust seems more variable than in milder areas such as the Eastern Downs and South Burnett.

Leaf, stem and head spot (*Alternaria helianthi*) presents a threat in the wetter areas of Queensland. The disease was initially recorded in north Queensland in 1972 and quickly spread to other areas of the State. This disease can reduce yields seriously. The fungus causes dark brown to black lesions, which can be rounded or angular. The lesions sometimes have a yellow halo around them.

Head rots are caused by *Rhizopus oryzae*. It requires some prior sunflower head injury and high humidity before infection occurs. While this injury is most commonly caused by insects; birds, mice and hail have also been responsible. Losses from head rots can be quite severe in periods of prolonged wet weather but there are no effective control measures.

Base and stalk rots are of minor importance overall but an occasional crop may be severely attacked.

White blister rust (*Albugo tragapogonis*) is often quite conspicuous in Queensland sunflower crops but it mainly affects the older, less useful leaves and does not affect the crop sufficiently to warrant control.

## Harvesting

Timely harvesting of sunflowers is very important. If harvesting is delayed until the plants become very dry, they break up in the

header and the trash cannot be properly separated from the seed. Delayed harvesting also reduces the seed oil content. Harvesting should be attempted when 80% of the heads are brown. Crops can dry out quickly from that stage.

Sunflowers in good harvestable condition will pass through a header with little break up of the stems or backs of heads. This allows much faster heading and less crop loss or damage from excessive repeat material.

Header fronts must be fitted with trays which are available commercially or may be made in the farm workshop. Earlier versions were wide to suit set row widths such as 75 cm or 1 metre. The trays are now usually much narrower so that any row width crop can be handled easily. The very low drum speed required may necessitate the purchase of special drive pulleys or sprockets.

The concave clearance should be wide and very little wind should be applied to the sieves. Repeats to the drum should be reduced to a minimum to avoid excessive cracking. On some headers, repeats can by-pass the drum. A plain round hole lower sieve is more effective than the adjustable type supplied in many headers. The hole diameter should be 9.5 to 11 mm depending on seed size.

A final screen fitted to the header can further improve the sample by removing fine material which is a fire hazard in heated air driers. Some farmers have found that fitting 8 or 9.5 mm square woven wire mesh over the straw-walkers eliminates most of the blockages that otherwise occur.

A further header front modification which is very effective especially in harvesting uneven sunflower crops, consists of a curved shield over the sunflower trays and a beater over the knife. The curved shield pushes the sunflowers gently forward and down until little more than the head is left at the header front level and cut by the knife. The beater then ensures a smooth flow of sunflower heads to the front auger and consequently to the drum. This modification greatly reduces the quantity of plant material taken into the header and consequently allows faster harvesting.

## Drying

Sunflowers will need to be dried if they are harvested at the optimum time. Due to their

This diagram of a header front modification which has proved very useful in tall or uneven crops was first published by the Queensland Graingrowers' Association. Sunflower trays must always be fitted for efficient harvesting.

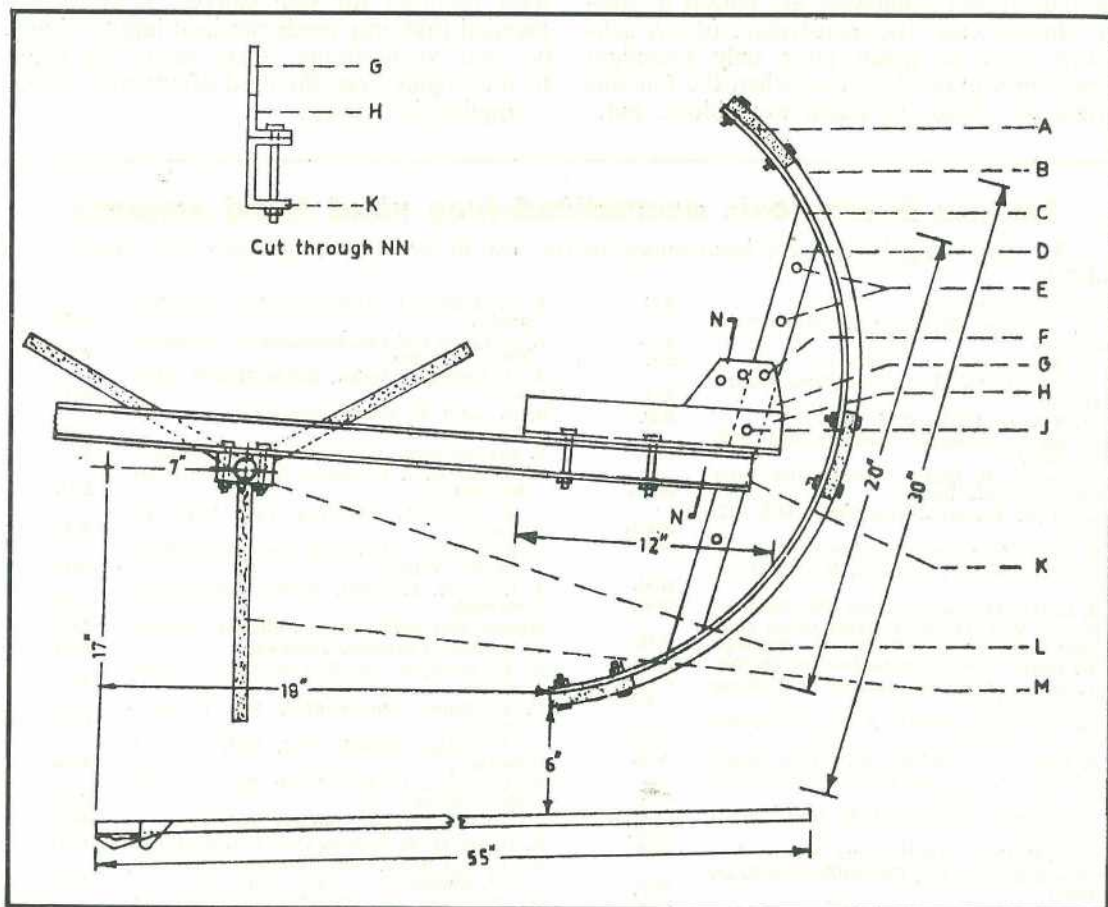

#### KEY TO LETTERS

- A. 1 in. x 4 in. board, full width of header.
- B. 28 gauge sheet metal shield.
- C. 1 in. x  $\frac{1}{4}$  in. strap iron, 36 in. long, shaped to an arc 30 in. across.
- D. 1 in. x  $\frac{1}{4}$  in. angle iron, 20 in. long, welded to C.
- E. Holes 3 in. apart, permitting adjustment of shield height relative to beater.
- F. Holes in an arc, which, with pivot hole J, permit adjustment of shield slope.
- G. Small  $\frac{1}{4}$  in. iron plate welded to H.
- H.  $1\frac{1}{2}$  in. x  $\frac{1}{4}$  in. angle iron, 12 in. long.
- J. Pivot hole, which, with F, permits adjustment of shield slope.
- K. Channel iron support for original reel.
- L. Reel boxing.
- M. Reel arm of 1 in. x 12 in. board.

high oil content, they present a considerable fire risk in a high temperature grain drier. Spontaneous combustion can occur within a few days if wet sunflowers are placed in storage. In one case, the temperature of wet sunflowers rose so much after only overnight storage in a grain drier that when the fan was turned on, clouds of steam were blown out.

High temperatures could adversely affect oil quality as well as increase fire risk. As sunflowers are easily dried to the 9% moisture level required for safe storage, it is recommended that only moderate heat inputs, if any, be used when drying. Care should be taken to thoroughly cool the seed afterwards if heat is applied for drying.

## Bovine brucellosis accredited-free stud herd scheme

The following herds have been added to the list of certified brucellosis free herd as at 1-4-78.

Agar Pastoral Co., P.M.B. 3, Murgon	<b>S.G.</b>	A. J. Kinbacher, Garthowen, P.S. 1216, Biggenden	<b>D.M.</b>
N. D. Bahnsch, Brafield Stud, Orchardvale, Guluguba	<b>B.F.</b>	S. G. Knight and Co., Baalgammon, Manumbar Road, Nanango	<b>A.I.S.</b>
H. A. Blake, Balhaven, Westbrook	<b>J.S.</b>	A. F. Krinke, Plainview, G.P.O. Box 92, Pittsworth	<b>H.F.</b>
D. J. and E. M. Beal, Tara Park, Gowrie Junction	<b>M.G.</b>	B. R. and J. H. Kummerfield, Lonley, c/- P.O. Box 7, Goovigen	<b>G.S.</b>
M. G. Bell, Heatherlea Stud, Dulacca	<b>B.F.</b>	F. Lax and Sons, Wyroona, M.S. 212, Oakey	<b>F.S.</b>
T. G. and M. K. Black, Hazeldean Stud, M.S. 692, Nanango	<b>S.G.</b>	R. S. and R. I. Learmont, Scotlea, P.O. Box 102, Monto	<b>S.G.</b>
N. J. and E. B. Blumel, Willow Glen Farm Stud, Farm Rd., Bunya	<b>D.M.</b>	L. K. Lostroch, Shamrock Vale, M.S. 212, Oakey	<b>A.I.S.</b>
Estate of W. Bourke, College Green, M.S. 422, Clifton	<b>A.I.S.</b>	C. R. and J. L. Marquardt, Cedar Valley Stud, Box 69, Wondai	<b>A.I.S.</b>
R. R. and I. A. Bowen, Pine Tree Farm, Roma	<b>H.F.</b>	S. J. and H. E. Miller, Nardoo, Miller Street, Warwick	<b>S.M.</b>
R. B. Clarke, Allawah, P.O. Box 476, Theodore	<b>B.M.</b>	Mimosa Stud and Cattle Co., Mimosa, Gayndah	<b>D.M.</b>
S. H. and V. I. Davidson, Cedar Grove Stud, Cedar Creek Road, Wolfdene, via Beenleigh	<b>B.M.</b>	L. R. Pain, Cabandah, Jandowae	<b>B.F.</b>
K. W. Davis, Walkah, Carpendale, via Helidon	<b>P.H.</b>	A. F. Paton, Warragah Stud, M.S. 30, Millmerran	<b>S.G.</b>
G. F. and A. M. Dean, Gadfield Stud, Home Creek, Wooroolin	<b>J.S.</b>	C. F. Paton, Glenroy Stud, M.S. 30, Millmerran	<b>S.G.</b>
E. O. and L. A. Dorries & Son, Panorama, M.S. 212, Oakey	<b>C.H., S.M.</b>	E. A. Paton, Sherdale Stud, M.S. 30, Millmerran	<b>S.G.</b>
L. J. Drew, Bluevale Stud, M.S. 1116, Haden	<b>A.I.S.</b>	A. V. Peters, Gladwyn Cattle Co., M.S. 892, Meringandan	<b>A.G.</b>
J. A. and D. P. Ferguson, Dorallah Stud, Veresdale, via Beaudesert	<b>A.Y.</b>	C. and E. L. Prosser, Thuruna Stud, Tara	<b>H.F.</b>
G. C. Fischer, Karalee Stud, 68 Hume Street, Pittsworth	<b>J.S.</b>	R. D. and G. R. Radunz, Cool Hill, Wooroolin	<b>S.G.</b>
F. and I. C. Fraser, Dundee Stud, Richmond	<b>M.G.</b>	W. E. and R. M. Rose, Rosevale Stud, M.S. 1184, Murgon	<b>F.S.</b>
Garryowen Pastoral Co., Corolla Stud, M.S. 29, Clifton	<b>B.M.</b>	W. Ross and Co., Starview Stud, M.S. 23, Rosewood	<b>A.I.S.</b>
C. Gauld, Moongana, Broooveena	<b>H.F.</b>	Estate of W. T. Savage, White Park, M.S. 852, Toowoomba	<b>A.I.S.</b>
Gayway Pastoral Co., Gayway, Anduramba	<b>S.G.</b>	B. and T. Schmidt, Bando, Wyandra	<b>B.M.</b>
W. W. Gibson, Glencrest, Mooloo via Gympie	<b>B.M.</b>	N. K. and S. B. Shelton, Vuegon, Hivesville	<b>B.F.</b>
Goondicum Pastoral Co., Goondicum, Gin Gin	<b>G.S.</b>	F. H. and E. Smith, Sommerville Stud, Brahmeadows, M.S. 1883, Rockhampton	<b>B.M.</b>
R. N. and L. M. Graham, The Homestead Stud, Couper's Road, Westbrook	<b>H.F.</b>	L. W. and K. J. Smith, Judi-Jindi Stud, M.S. 501, Dalby	<b>B.F.</b>
G. A. Greenup and Co., Benroy, Kingaroy c/- Rosevale, Jandowae	<b>F.S.</b>	M. T. and B. R. Smith, Pamalyn, Wellcamp	<b>F.S.</b>
D. H. and P. O. Guilford, Mooloolah Stud, Richmond, Allora	<b>S.G.</b>	A. H. and B. J. Springall, Beralan Stud, Imbil	<b>B.F.</b>
N. D. and A. V. Hams, Shandah, P.O. Box 89, Nanango	<b>H.F.</b>	N. L. Stiller, Vine Veil, Guluguba	<b>P.H., H.F., C.H. Cross</b>
H.M. State Farm, Palen Creek, Rathdowney	<b>S.G.</b>	J. R. Williams, Forest Glen, Columboola	<b>B.F.</b>
H.M. State Prison, Wolston Stud, Station Road, Wacol	<b>J.S.</b>	A. R. and G. G. Wockner, Durn Stud, MacLagan	<b>A.G.</b>
N. T. and M. A. Hoey, Merrawah Stud, M.S. 371, Greenmount	<b>D.M.</b>	J. B. Wyatt, Rokeby, Warwick	<b>H.F.</b>
B. C. Juers, Mimosa B.J. Stud, Mimosa, Gayndah	<b>SH-CH</b>	Dr. B. R. Yeates, Ugarapul, Boonah	<b>D.M.</b>
J. T. and F. Kelman, Mt. Tabor Station, Warwick	<b>Cross</b>	R. and J. Ziesemer, Belbar Stud, Bell	<b>H.F.</b>

### KEY

Angus  
Australian Illawarra Shorthorn  
Ayrshire  
Braford  
Brahman  
Chianina  
Droughtmaster  
Friesian

A.G. Guernsey  
A.I.S. Hereford  
A.Y. Jersey  
B.F. Murray Grey  
B.M. Poll Hereford  
C.H. Santa Gertrudis  
D.M. Shorthorn  
F.S. Simmental

G.S.  
H.F.  
J.S.  
M.G.  
P.H.  
S.G.  
S.H.  
S.M.

# Sugarcane mosaic virus in sorghum

by D. M. Persley, Plant Pathology Branch.

A JOHNSON grass strain of sugarcane mosaic virus can be a serious problem in sorghum crops in southern and central Queensland.

Resistant breeding lines have now been released by the Queensland Department of Primary Industries for the production of resistant hybrids.

## Symptoms

The symptoms shown by affected plants depend on the cultivar and environmental conditions and can be divided into three characteristic types.

**MOSAIC.** The most common symptom is a pattern of light green and dark green lines parallel to the leaf veins (plate 1). These symptoms are most evident on the young whorl leaves and fade as plants mature. The majority of commercial cultivars show mosaic symptoms.

**RED LEAF.** In some cultivars, the mosaic pattern changes to a severe red leaf symptom after a period of cool, overcast weather. Red leaf is characterized by severe leaf reddening followed by the formation of red spots, streaks and areas of dead tissue (plate 2). Severe symptoms at flowering can cause head blast.

If conditions suitable for red leaf development persist, death of plants often occurs. Otherwise, mosaic symptoms reappear on the new growth when higher summer temperatures return.

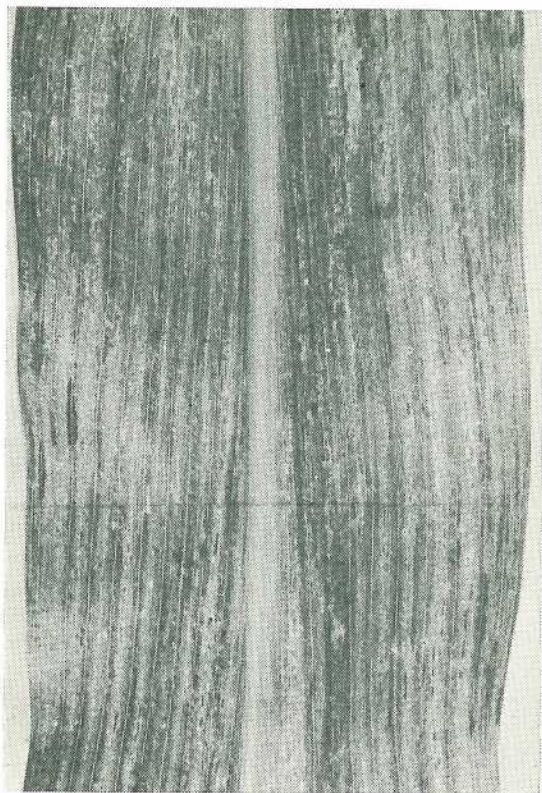

Plate 1. Mosaic pattern of light green and dark green lines parallel to veins.

**RED STRIPE.** A few cultivars produce conspicuous red or tan stripes parallel to the veins. Early infection results in severe stunting or death with surviving plants often showing prominent yellow mosaic symptoms on the new growth.

Red stripe occurs in susceptible cultivars under all weather conditions while red leaf occurs in some other cultivars only after cool weather.

## Cause

The symptoms described are the result of infection by a Johnson grass strain of sugarcane mosaic virus. This strain survives between seasons in Johnson grass (*Sorghum halepense*) or in standover forage sorghum plants. Diseased Johnson grass occurs throughout southern and central Queensland.



Plate 2. Severe red leaf symptoms on a sorghum cultivar.

A number of related virus strains are associated with other grass species but only the Johnson grass strain occurs in sorghum. This strain also causes maize dwarf mosaic disease. (*Queensland Agricultural Journal*, November 1976).

Sugarcane mosaic virus affects many grasses. All grain and forage sorghums, sorghum-sudan grass hybrids, *Sorghum almum*, *S. verticilliflorum*, *S. sudanense*, broom millet and native *Sorghum* species are susceptible.

### Spread

The virus is spread from plant to plant by several species of aphids. The corn aphid (*Rhopalosiphum maidis*) is the most prevalent carrier (vector) in sorghum crops. Winged aphids from outside a crop play an important role in virus spread. As these

winged insects often feed for only short periods, insecticides are of little value in disease control.

### Importance

Sugarcane mosaic virus commonly infects sorghum crops in south-eastern Queensland, the Darling Downs, and central Queensland.

The infection level in crops varies from a trace to total infection. Grain sorghum crops commonly have 20 to 30% of affected plants although levels in excess of 50% do occur and total infection of ratooned grain and forage sorghum crops is common. The effect of the virus on yield depends on the time and level of infection, cultivar and weather conditions.

A high incidence of early infection can cause serious yield reductions, particularly in cultivars susceptible to the red stripe and red



Plate 3. A sorghum plant showing severe red stripe.

leaf symptoms. In field trials at the Hermitage Research Station, the yields of cultivars producing these symptoms were more than halved. The effects on mosaic reacting cultivars were less and varied considerably between cultivars and seasons. Two of the ten cultivars tested showed little yield reduction from the virus.

### **Control**

Severe yield losses can be prevented by avoiding cultivars susceptible to the red stripe and red leaf symptoms. Information on the reaction of commercially available cultivars to sugarcane mosaic virus appears in the Grain

Sorghum Planting Guide published each year in the July issue of the *Queensland Agricultural Journal*.

The use of resistant cultivars is the best means of control. A breeding programme aimed at producing breeding lines and hybrids with high resistance is nearing completion at the Hermitage and Biloela Research Stations. Four resistant lines were released in 1972. Further lines with uniform resistance and agronomic characters have recently been released by the Department and are being used by commercial companies for the production of virus resistant hybrids.

---

## **New director of Dairy Research Branch**

The new Director of the Dairy Research Branch in the Department of Primary Industries is Miss Ailsa Gillies, M.App.Sc. (Med.), who has been assistant Director since October, 1974.

Miss Gillies replaces Mr W. C. T. Major, who retired in March.

Announcing her appointment, the Minister for Primary Industries, Mr V. B. Sullivan, said Miss Gillies first joined the Department in 1952 as a laboratory assistant in the Dairy Research Laboratory at Toowoomba.

Miss Gillies had been transferred to Brisbane in 1957 as an assistant Dairy Technologist and appointed a Special Bacteriologist in 1965. She was appointed Senior Bacteriologist in 1971.

'During recent years, Miss Gillies has played a major role in the development of new dairy foods at the Otto Madsen Dairy Research Laboratory at Hamilton, Brisbane,' Mr Sullivan said.

'A number of these products have been manufactured and marketed commercially.'

Mr Sullivan added that, during her long period of service with the Department, Miss Gillies had carried out extensive research on dairy products, particularly milk and cheese, and had contributed a number of scientific papers relating to this work.

# Milkfat . . . what is it?

ONE of the earliest characteristics of milk observed by man was its tendency to settle into two layers.

Examination of the top layer or cream showed that it contained a large proportion of fat (up to 50%). It was soon discovered that this fat could easily be manufactured into concentrated food products (such as butter and ghee) that had higher food value and longer storage lives.

For many years, milkfat was considered to be a single substance. However, observations by farmers, buttermakers and scientists indicated that its composition could vary widely. The most noticeable differences were changes in colour, taste and smell, but buttermakers also observed changes in softness and spreadability. It became obvious that milkfat was not a single substance.

It has since been found that a number of factors can influence the composition of milkfat. Among these are: breed of cow and type and amount of feed. Obviously then, if we are to be able to manufacture the best possible products from milkfat, we will need to understand the effects of these factors on its composition. But before this is possible we will require a sound knowledge of the composition and structure of milkfat.

## What is milkfat?

Milkfat like all other fats such as tallow and lard consists chiefly of chemical units called triglycerides. There are many other important constituents in milkfat such as cholesterol and vitamin A but these are in very small amounts and do not usually affect the properties of the milkfat. One exception to this is beta-carotene which is responsible for the yellow colour of milkfat.

## What is a triglyceride?

A little understanding of basic chemistry is required at this point. A triglyceride is a chemical unit (called a molecule) that is formed by the union of four other chemical units. One

of these is the commonly encountered glycerine (glycerol). The other three are called fatty acids. Each fatty acid contains a chain of carbon atoms. The number of carbon atoms in its chain determines the type of fatty acid.

In other words, one type of fatty acid contains four carbon atoms linked together while another contains six carbon atoms and so on. These are usually written as C4, C6, etc. There are approximately 20 fatty acids of importance in milk and these have carbon chains extending from 4 to 20 long.

To form a triglyceride, one glycerol unit must join to three fatty acid units, not necessarily the same type). See figure I. Because there are over 20 different fatty acid types, it is possible to have over  $20^3$  ( $20 \times 20 \times 20 = 8000$ ) different triglyceride structures in milkfat. It is the composition of these triglycerides that governs the properties of milkfat and makes it different from all other fats.

It is important to realise that when union of one glycerol unit and three fatty acid units occurs, the properties (taste, smell, appearance, etc.) of the triglyceride unit are no longer the same as those of the individual components. For example, a milkfat which is a creamy, almost odourless solid at normal temperatures is produced from glycerol which is a thick viscous liquid, and fatty acids some of which have very strong, pungent odours.

## Where do triglycerides come from?

Milkfat triglycerides are made in the udder (mammary gland) of the dairy cow where the glycerol and fatty acids are brought together. Glycerol is not usually consumed directly by the cow but is mainly produced from glucose by a complex set of chemical reactions. The fatty acids are obtained from two major sources and can be split on this basis into three groups:

- **GROUP 1.**—Contains the short chain acids, C4 to C10, which are produced in the mammary gland from other chemical compounds (acetic acid for one) consumed by the cow or produced by bacteria in its first stomach (or rumen).

---

by J. W. Aston, Dairy Research Branch.



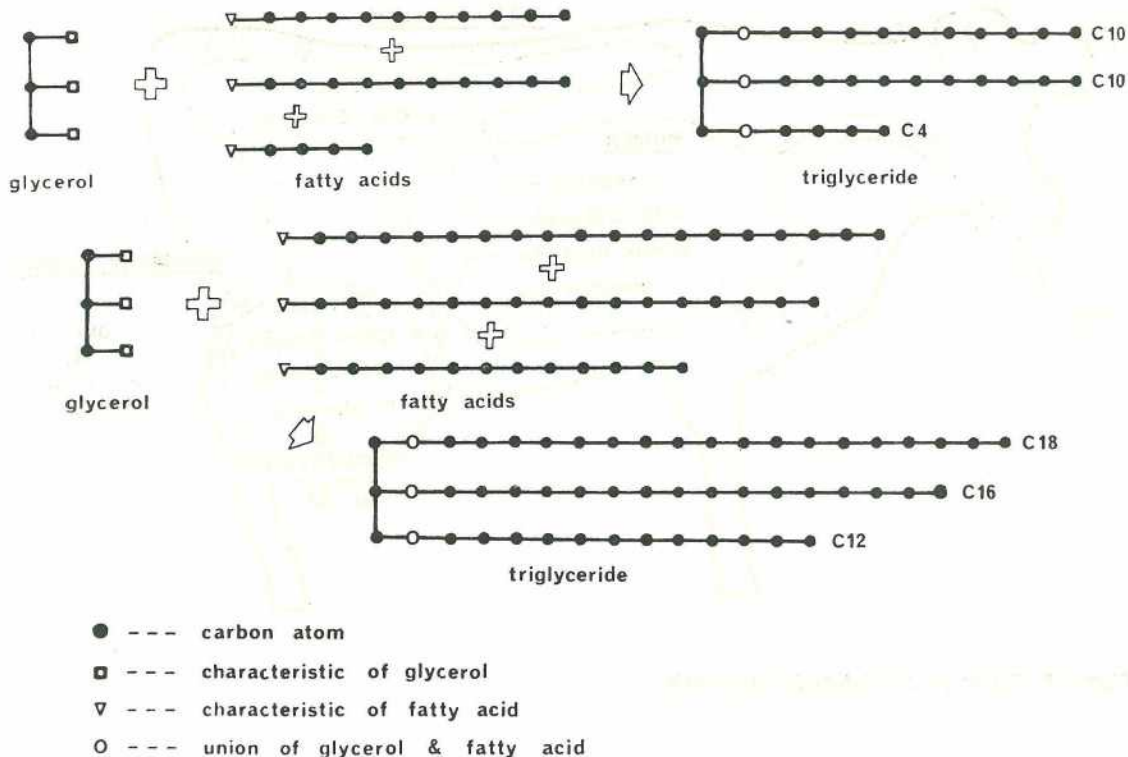

Figure 1. Diagrammatic representation of triglyceride formation.

- **GROUP 2.**—Contains the long chain acids, the major ones of which contain 18 carbon atoms. These acids cannot be produced within the cow and therefore have to be consumed in her diet. The cow is able to store these acids in her fatty tissues for later use.
- **GROUP 3.**—Consists of the intermediate length acids, that is, C12 to C16. These acids can be derived from either of the above two sources.

### How and why does the composition of milkfat vary?

There are several consequences arising from the fact that there are two different sources of fatty acids for milkfat. The major one is the effect that diet can have on the fatty acid composition of the milkfat. For example, in

winter when only low quality pasture is available to dairy cows, the supply compounds for the synthesis of C4 to C16 acids is reduced and consequently the levels of these acids in the mammary gland are reduced. To maintain a consistent level of fat in the milk, the cow can call on her body fat reserve to make up the fatty acid deficiency.

As pointed out earlier, it is mainly the long chain acids (C18 etc.) that are stored in the fatty tissues and therefore the milkfat produced will have increased levels of C18 and decreased levels of C4 to C16. Any occurrence that reduces the quality of food intake has a similar effect on the composition of milkfat and, in fact, scientists are now determining the ratio of short chain acids to long chain acids to estimate the levels of nutrition of animals on different feeds.

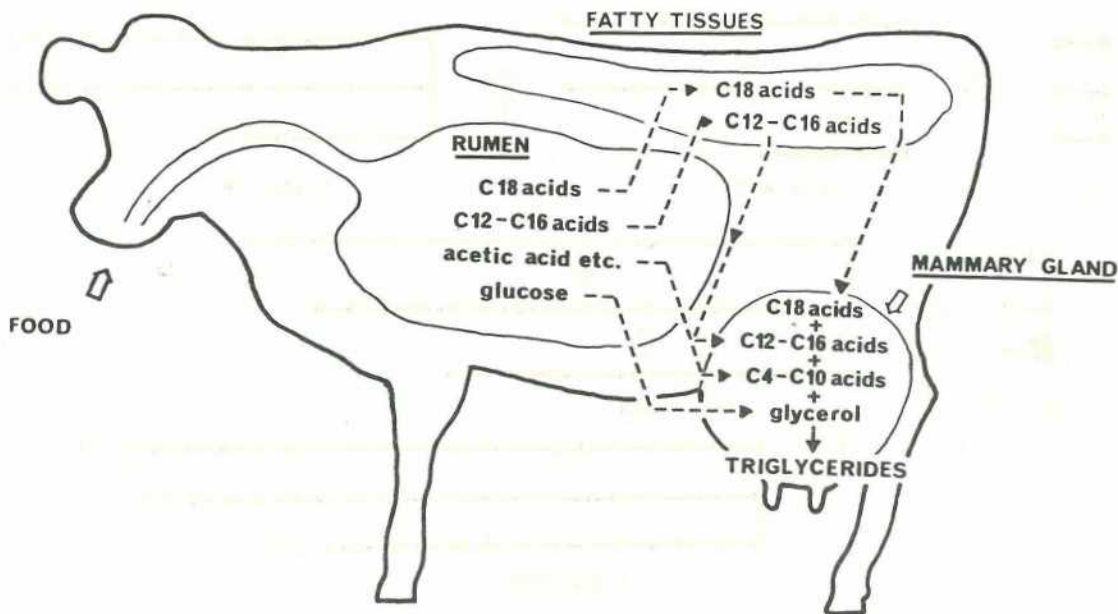

Figure 2. Pathways of triglyceride synthesis.

### To summarize

- Milkfat consists chiefly of triglycerides.
- A triglyceride is a chemical compound formed from the union of one unit of glycerol with three units of fatty acids.
- There are 20 major fatty acids in milkfat having carbon chain lengths of from 4 to 20.
- Because there are over 20 types of fatty acids in milkfat, it is possible to have over 8000 different triglyceride structures.
- The triglycerides are produced in the mammary gland from glycerol and fatty acids.
- The C4 to C10 acids are manufactured within the mammary gland from simpler compounds consumed by the cow.
- The C18 acids are consumed as such and stored in the cow's fatty tissue until required.
- The C12 to C16 acids are derived from both of these sources.
- Any event that reduces the availability to the cow of the compounds from which the C4 to C6 acids are produced reduces their levels in milkfat.
- To maintain a consistent fat level in the milk, the cow calls on its fat reserves (C18) to make up the deficiency.
- The result is that the milkfat produced has reduced C4 to C16 levels and increased C18 levels.
- Scientists can measure the ratio of short chain acids to long chain acids in milkfat to estimate the level of nutrition of an animal.

In the past few years, there has been much publicity given to terms such as saturated fat, unsaturated fat and polyunsaturation. All of these are relevant to milkfat and have considerable effect on its properties (softness, keeping quality, flavour defects, etc.).

In a future article, the meaning of these and their effects on milkfat properties will be discussed.

# Wheat and barley variety testing

## In central Queensland

PRIOR to 1971, wheat and barley variety testing in central Queensland were mainly carried out at the Biloela Research Station, where such work commenced in the 1930s.

Over this period, variety trials were also occasionally conducted on properties in both the Dawson-Callide and Central Highlands areas.

In 1971, the Queensland wheat variety testing programme was expanded to compare promising new lines from various wheat breeding programmes with commercial varieties over a wider range of locations. New lines showing superior performance in respect of grain yield, quality, rust resistance or other agronomic characteristics over a 2 to 3 year period are considered for release as commercial varieties. Results obtained from the programme are also used to assist in forming district varietal recommendations.

Under this scheme, 20 to 25 trials containing quick-maturing wheat varieties are planned for Queensland wheat growing areas each year, with approximately eight of these in central Queensland. A smaller number of trials containing varieties of midseason maturity are also conducted each year, with one or two being located in central Queensland.

The number of barley variety trials in this region has been increased to five a year since 1971 as part of the varietal evaluation programme in this crop which is centred in southern Queensland.

by G. A. THOMAS and J. H. LADEWIG, Agriculture Branch.

The wheat and barley variety trials contain up to 15 entries. To overcome site variability, a number of plots of each variety are planted in each trial. The data collected from each trial are analysed statistically to obtain a measure of the variability associated with it.

A small plot autoheader with a 1.8 m front is used to harvest the grain from the plots. The grain from each plot is weighed to enable yield to be calculated.

Grain samples from all wheat and barley variety trials undergo quality evaluation by the cereal chemistry section at the Queensland Wheat Research Institute.

Since 1969, evaluation of large numbers of early generation and more advanced lines from the Queensland wheat breeding programme, as well as of introduced wheat lines from interstate and overseas, has also been carried out in both the Dawson-Callide (Biloela Research Station) and Central Highlands (Capella or Gindie) areas.

This work has been carried out by members of the plant breeding team from the Queensland Wheat Research Institute, who also conduct similar trials in the southern wheat belt. Officers stationed in central Queensland have also given assistance with these trials in their area. The most promising strains from these trials are subsequently included in the wheat variety testing programme for evaluation at a wider range of locations.

### Wheat variety trials

- RAIN-GROWN. Over the five years 1972 to 1976, 23 quick-maturing wheat variety trials were harvested in the Dawson-Callide area and 14 in the Central Highlands. The time of planting ranged from early May to mid July, depending on the occurrence of adequate planting rain.

Grain yield results for present commercial varieties included in these trials are shown in table 1.

TABLE 1  
GRAIN YIELD OF QUICK-MATURING WHEAT VARIETIES IN CENTRAL QUEENSLAND 1972-1976  
GRAIN YIELD (tonne/per ha)

Variety	Dawson-Callide						Central Highlands					
	1972	1973	1974	1975	1976	Mean	1972	1973	1974	1975	1976	Mean
1. Kite .. .. .	1.62	2.19	2.45	2.08	2.25	2.12	1.41	2.05	1.53	1.21	1.29	1.58
2. Gatcher .. .. .	1.72	2.29	2.31	1.81	2.18	2.08	1.23	2.23	1.48	1.12	1.14	1.56
3. Timgalen .. .. .	1.57	2.11	2.12	1.75	2.12	1.93	1.29	2.12	1.41	1.10	.99	1.50
4. Spica .. .. .	1.22	1.93	2.01	1.81	2.28	1.84	1.42	1.82	1.31	1.25	1.22	1.45
5. Mendos .. .. .	1.50	1.85	2.09	1.58	2.10	1.82	1.19	1.83	1.31	1.05	.98	1.36
6. Gamut .. .. .	..	2.00	2.30	..	..	..	..	1.91	1.48	..	..	..
7. Songlen .. .. .	..	..	2.27	1.76	2.23	..	..	..	1.42	1.02	1.14	..
8. Cook .. .. .	..	..	..	1.91	2.24	..	..	..	..	1.15	1.32	..
9. Oxley .. .. .	..	1.99	..	..	..	..	..	1.57	..	..	..	..
MEAN VARIETIES 1 TO 5 ..	1.53	2.07	2.20	1.81	2.19	1.96	1.31	2.01	1.41	1.15	1.12	1.49
NUMBER OF TRIALS ..	5	6	4	4	4	..	2	4	4	3	1	..

Over the 5 years, Kite and Gatcher have given similar mean yields, slightly higher than that of Timgalen, in both areas. However, Kite has performed better in relation to Gatcher since 1974 than it did in the first 2 years of its inclusion.

Kite, Gatcher and Timgalen, together with the new varieties Songlen and Cook are the currently recommended quick-maturing varieties for central Queensland. All are presently resistant to field strains of stem rust, but only Songlen is resistant to leaf rust.

The non-bearded, semi-dwarf variety Kite has shown a marked yield advantage over Mendos, which it replaced as a recommended variety for the region. Kite appears to withstand weather damage to the grain better than other varieties, but has the disadvantage of not being acceptable as a Prime Hard variety because of certain deficiencies in quality. It is not as free threshing as the other recommended varieties, but is less prone to lodging.

Gatcher and Timgalen are both awned varieties of medium height and good grain quality.

Songlen, a semi-dwarf, awned variety which has been included in the trials since 1974, has generally given similar yields to Gatcher

and Timgalen. However, compared with Timgalen, it has an additional gene protecting it from stem rust.

Cook, in the 2 years in which it has been included in the trials, has generally yielded slightly better than the other Prime Hard varieties, Gatcher, Timgalen and Songlen. Cook is an awned, semi-dwarf variety of slightly later maturity (2 days) than Timgalen and of excellent grain quality.

Spica has performed relatively well in some years, particularly in the Central Highlands, while Mendos did not generally yield well in relation to the recommended varieties. Gamut yielded relatively well in the trials in which it was included. These three varieties are no longer recommended for the region because of their susceptibility to stem rust.

Oxley was included in this series of trials in 1973 and did not generally yield as well as Kite, Gatcher and Timgalen. It was evident that the longer growing season of Oxley (average of 20 days later to flower than Gatcher) was a disadvantage under the dry conditions experienced in a number of trials. Most trials were also planted in June, later than the optimum time for a variety of mid-season maturity such as Oxley.

Four rain-grown midseason wheat variety trials were conducted at the Biloela Research Station from 1972 to 1975. Planting times were late April-early May for all except the 1974 trial, which was planted in late May.

Grain yield results for this series are given in table 2.

TABLE 2

GRAIN YIELD OF MIDSEASON WHEAT VARIETIES,  
BILOELA RESEARCH STATION 1972-75  
GRAIN YIELD (tonne/per ha)

Variety	1972	1973	1974	1975
Oxley .. ..	1.60	3.37	4.75	3.99
Festiguay ..	2.29	2.46	3.68	..
Tarsa .. ..	1.69	2.58	3.54	3.33
Timson .. ..	..	2.66	3.60	3.31

Oxley, a semi-dwarf, awned variety of Prime Hard quality has been the outstanding entry in this series of trials and has outyielded the previously recommended midseason varieties, Festiguay and Tarsa, by an average of 15% (3 trials) and 23% (4 trials) respectively. Most of these trials have been under good conditions, where the yield advantage of Oxley appears to be more pronounced. Oxley is now susceptible to stem rust, but has a useful level of resistance to leaf rust. It is also noted for its resistance to lodging.

Timson, a new awned, semi-dwarf variety of midseason maturity has not yielded as well as Oxley in trials, but is resistant to both stem and leaf rust.

TABLE 3

GRAIN YIELD OF WHEAT VARIETIES IN EMERALD IRRIGATION  
AREA 1972-1974  
GRAIN YIELD (tonne/per ha)

Variety	1972	1973	1974
Kite ..	2.82	3.17	..
Gatcher ..	2.34	2.30	..
Timgalen ..	2.38	2.97	2.84
Oxley ..	..	3.69	4.66
Timson ..	..	..	3.27

If a planting opportunity occurs in the mid-April to mid-May period, sowing a variety of midseason maturity such as Oxley can reduce the risk of frost damage to the crop, particularly in the Dawson-Callide area.

• IRRIGATED. Since 1972, a number of irrigated wheat variety trials have been conducted in the Emerald Irrigation Area and yield results are summarized in table 3.

Oxley has also been the outstanding variety in these trials and yielded an average of 44% higher than Timgalen over the 2 years 1973 and 1974.

Kite has also given higher yields than Timgalen and Gatcher in these trials by an average of 13% and 30% respectively over 2 years. However, Kite was significantly outyielded by Oxley in 1973, the only year in which both varieties were included in the trials.

The high yield potential of Oxley and Kite together with their good standing ability, make them very suitable for growing under irrigation.

#### Barley variety trials

Barley produced in central Queensland is mostly used as a feed grain as the grain protein content of barley grown in this region is generally too high for malting classification. The grain is also often pinched due to dry finishing conditions and this also makes it unsuitable for malting.

However, Clipper, the recommended malting variety, has also been the only variety recommended for central Queensland in recent years. Although other varieties have outyielded Clipper in trials, their widespread use has not been encouraged because of the possibility of their being accidentally included in the malting supplies.

The recently released feed grain variety Corvette, which has been included in the trials since 1974, has outyielded Clipper by an average of 20% in 13 trials in central Queensland over the 3 years 1974-1976 (table 4). Corvette has a very large seed with a distinctive blue colouration which makes it easily distinguishable from the registered malting quality varieties. Corvette has some resistance to the races of powdery mildew prevalent in Queensland and is also less susceptible to lodging than Clipper.

TABLE 4  
GRAIN YIELD OF BARLEY VARIETIES IN CENTRAL  
QUEENSLAND 1974-76  
GRAIN YIELD (tonne/per ha)

Variety	1974	1975	1976	Mean
Corvette ..	1.93	2.21	2.50	2.17
Clipper ..	1.51	1.68	2.15	1.81
Prior .. ..	1.83	1.62	2.14	1.81
MEAN .. ..	1.76	1.84	2.26	..
NUMBER OF TRIALS ..	5	5	3	..

### Wheat-barley comparison

Over the 5 year period 1972 to 1976, wheat and barley variety trials have been carried out adjacent to each other at 21 sites in central Queensland.

In these trials, the commercial wheat varieties Kite, Gatcher and Timgalen have outyielded Clipper by an average of 15%, 13% and 6% respectively.

The yields obtainable from the latest barley release Corvette (20% greater than Clipper) make barley more competitive with wheat as a feed grain, provided markets are available which will give comparable returns to wheat.

### Acknowledgements

Irrigated wheat variety trials at Emerald were supervised by G. D. Keefer, E. S. Uridge and L. J. Wade, Agriculture Branch. Dr P. S. Brennan and M. C. Cox, Queensland Wheat Research Institute, supervised a number of wheat variety trials in the Central Highlands area.

## Water-tight concrete

One very important factor in making concrete which is impervious to water is to keep the amount of water used in the 'mix' down to a minimum.

It is necessary that concrete used in the construction of structures such as tanks and dips should contain no more than 23 to 27 litres of water for every bag of cement. Thin sections demand that this should be reduced to 20 to 25 litres to the bag.

If too much water is used, air voids form as the concrete dries. This leaves it porous. A recommended water-tight mix is 3 parts gravel (not to exceed 3 cm diameter), 1½ parts medium sharp sand. Water-tight concrete necessitates the use of aggregate which is non-porous and it is better for the aggregate to be on the sandy side rather than a harsh nature.

When building walls for tanks and dips, a uniform consistency is vital. In the pour do not allow the mix to be dropped more than 150 to 180 cm to avoid segregation. Do not allow concrete to flow horizontally for any distance. It is important to distribute it in uniform layers 30 to 45 cm thick. Rodding or vibrating is necessary for each layer to consolidate the concrete.

by H. Woodings, formerly of Agriculture Branch.

## Identifying insects

# Order Lepidoptera—butterflies and moths

## Part 2—moths

MOTHS make up by far the greatest part of the order Lepidoptera with more than 10 500 described species (butterflies total about 360) in Australia.

Adult moths are naturally similar in structure to the butterflies. The wings and bodies are clothed in scales and they feed on liquids in the same way as butterflies. In contrast to butterflies, however, moths rest with their wings folded along the body. During flight each pair of wings is coupled by means of a strong bristle on the hind wing called the frenulum which is held under a series of short, curved bristles (the retinaculum) on the fore wing. Such a mechanism is necessary since the moths move their wings much more rapidly than butterflies, and the movement of the two wings would become un-coordinated if they were not locked together.

Like the butterflies, the immature stage of moths is also a caterpillar and it is largely the destruction due to their feeding that has resulted in moths being ranked as one of man's most serious insect enemies. Almost every plant crop is attacked in some way by moth larvae, be it in the field or after harvest; they invade our homes to attack clothing and carpets, and ravage lawns and ornamentals in our gardens.

In short, many moths can be a nuisance, but just as 'it's an ill wind that blows no good' we can be eternally grateful to the cactoblastis moth which liberated millions of hectares of Queensland from the grip of prickly pear during the 1920s and 1930s.

However, looking at the moths more closely we find that not all of them are drab. There are many individuals of great beauty

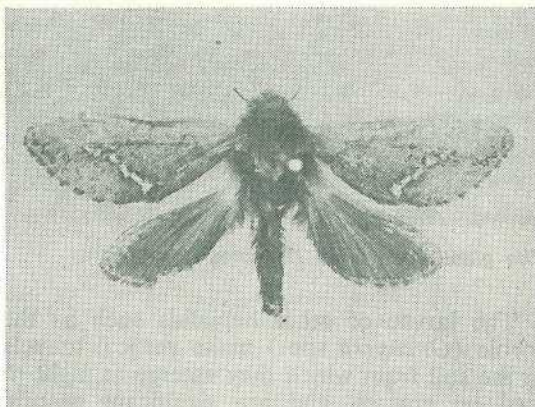

*The corbie (Oncopera brachyphylla).*

and there is a fascinating diversity of habits, shape and size which can be illustrated only briefly in this article.

### Family Hepialidae—swift moths

The swift moths are among the most primitive of all lepidoptera, but also include some of the most beautiful, with bright green and pink individuals being common in the genus *Aenetus*. Most are robust, fast-flying moths which do not feed.

They are short-lived and subsist on reserves accumulated in the larval stage. The larvae chew vertical tunnels in the stems of living trees. However these are not feeding tunnels but merely serve as day-time resting sites and for pupation. The real food of the larva is bark regrowth around the entrance to the tunnel which the larva covers with a curtain of frass and wood particles webbed together. These brown mats are quite obvious against the bark, and a short walk around almost any piece of bushland will reveal surprising numbers of these larvae.

---

by B. K. Cantrell, Entomology Branch.

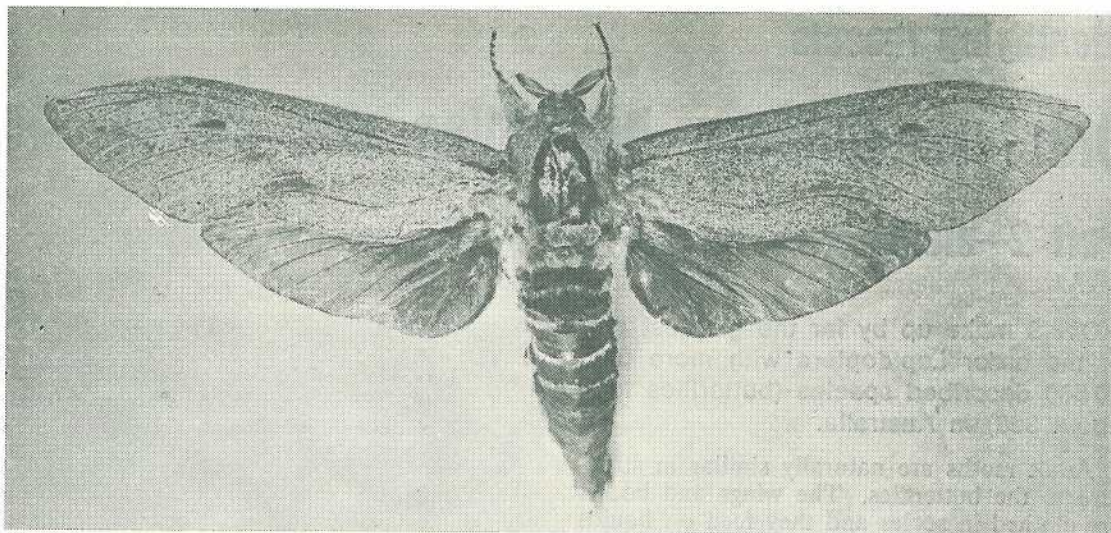

*The giant wood moth (Xyleutes boisduvali).*

The larvae of other hepialids such as the corbie (*Oncopera* spp.) make vertical tunnels in the soil from which they emerge at night to feed on grasses, and are significant pasture pests on the Atherton Tablelands. Severe infestations can leave large, bare areas of dead grass, considerably reducing yield, and allowing the invasion of weeds.

#### **Family Cossidae—wood moths**

The cossids include some of the largest moths which are mostly mottled grey in colour and can attain a wing span of more than 20 cm. The larvae bore in the heartwood and larger roots of living trees and development may occupy 2 to 3 years.

The wattles are particularly susceptible and trees may become so weakened by tunnelling larvae that they snap off at the base during strong winds. The adults do not feed and are short-lived. The genus *Xyleutes* has many species of very large moths, the females of which may lay enormous numbers of eggs (in one recorded instance a single female laid more than 18 000 eggs).

#### **Family Tortricidae—leaf rollers, bell moths**

Most tortricids are small moths with a wing span seldom exceeding 2.5 cm and are generally drab browns and greys although some are attractively patterned. The habits of the larvae are so diverse that it is not possible to

list them all. Many species are found on the forest floor where they feed on fallen leaves and are important in humus production. Others web living leaves together or roll them up to form a feeding shelter, a few are flower feeders and some attack developing seeds in pods still on the plant, to give but a few examples.

The family includes several economic pests such as the lucerne leaf roller (*Merophyas divulsana*), the macadamia nut borer (*Cryptophlebia ombrodelta*) and the apple pests, codling moth (*Cydia pomonella*) and light brown apple moth (*Epiphyas postvittana*).

One useful species is the lantana flower caterpillar (*Epinotia lantana*) which was introduced from overseas to assist other insects in the control of this weed.

#### **Family Psychidae—bag moths**

The bagmoths are generally better known by the larvae which drag along their portable cases wherever they go. Most feed at night on the leaves of shrubs and trees and their cases can often be seen hanging from branches. Others feed on mosses and lichens and are less obvious since they ornament their case with fragments of their food and are difficult to detect. The adults are seldom seen and, in fact, the females of some species are wingless and never leave the larval case.



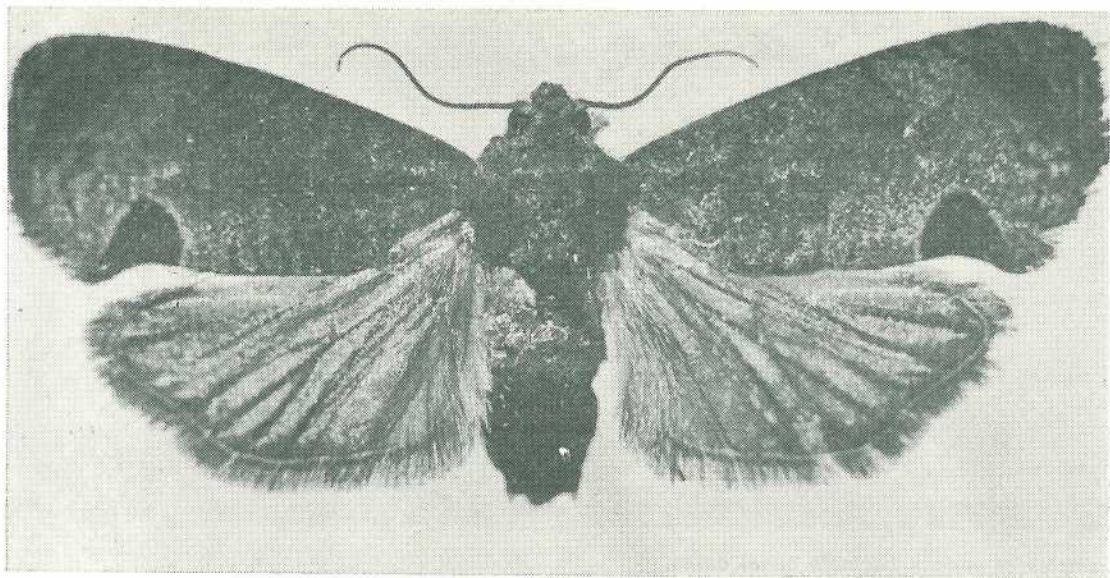

*The macadamia nut borer (Cryptophlebia ombrodelta).*

Bagmoth larvae spin for themselves a tough, silken case which they ornament with sand, fragments of twigs, leaves, moss, etc. and which is enlarged as they grow. The bags have a hole through which the larva feeds and a smaller hole at the other end through which the faeces are expelled. Each species has its own special way of case making so that they can usually be recognized very easily.

Wingless females attract males with chemical lures and mating is accomplished inside the case since the males have highly elastic abdomens, which are pushed through the smaller opening. The eggs are laid inside the case and the larvae crawl out after hatching.

The feeding of larvae normally does not cause economic loss although outbreaks of *Hyalarcta huebneri* have been a cause for concern in forestry pine plantations in recent years. The adult males have almost transparent wings devoid of scales and very dark bodies.

#### **Family Tineidae—clothes moths**

Mention of clothes moths to most people conjures up a vision of an expensive woollen garment discovered in the wardrobe with

just enough damage to render the item useless. The damage is the work of the larvae of two tiny silver-grey moths, the case-making clothes moth (*Tinea pellionella*) and the webbing clothes moth (*Tineola bisselliella*) which were probably brought to Australia with the first fleet in 1788.

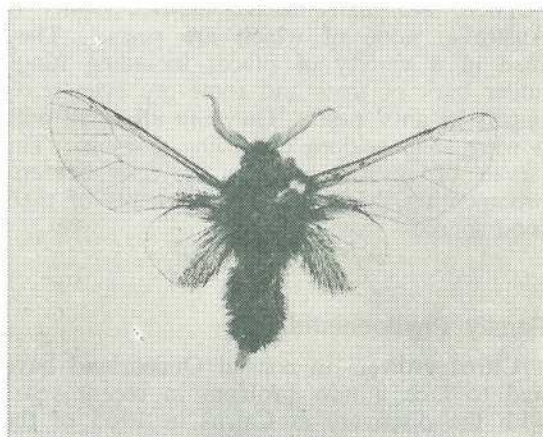

*Male bagmoth (Hyalarcta huebneri).*

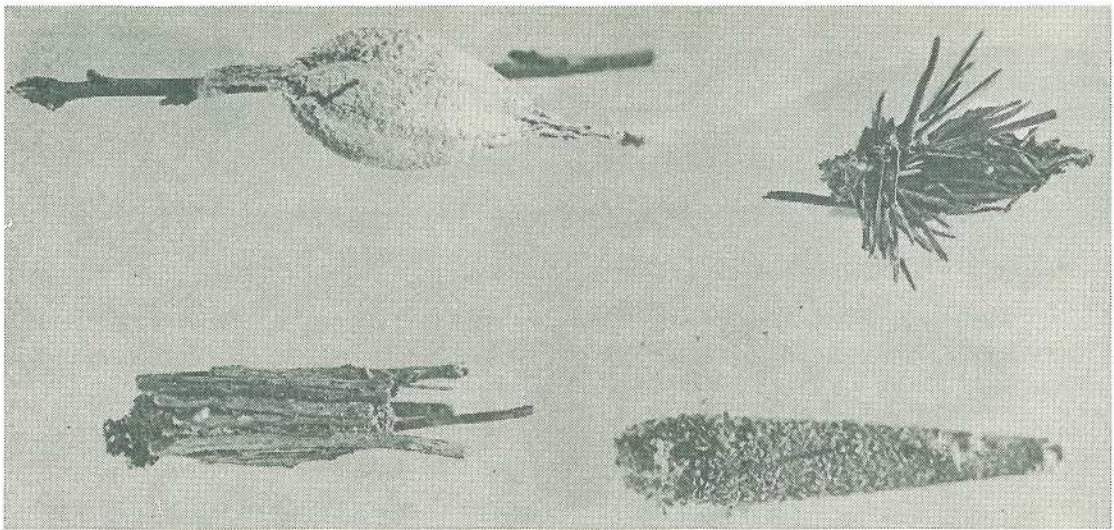

Examples of various bagmoth larval cases.

The clothes moths belong to a group of insects who have learnt to utilize the protein in animal fibres. As a result, only woollen items are attacked, cotton and synthetic materials being quite safe. It is recommended that each spring, winter clothes be cleaned and stored in air-tight plastic bags containing naphthalene flakes. After a thorough airing, the garments will be ready for use when needed next season.

There are many native clothes moths in Australia, none of which are pests. They feed in a variety of places including fungi, under bark of trees and some are even scavengers in ants' nests. They are all small with a wing span seldom exceeding 1.5 cm. The larvae of several species are case bearers, ornamenting the case with fragments of their food source.

### Family Phyllocnistidae

Citrus growers in coastal Queensland have had to face a new problem in recent years with the discovery at Cairns in 1965 of the citrus leaf miner (*Phyllocnistis citrella*). Since then, the insect has spread southwards to the south-east portion of the State.

The adult insect is a very tiny, shining, white moth which lays its eggs on the soft new growth of all varieties of citrus trees. The larvae enter the leaves and feed between the upper and lower leaf surfaces, producing transparent mines which wander erratically over the leaf surface as the larvae grow. As a result of this activity the leaves usually wrinkle and curl up at the edges. Young trees are most affected as they are less able to withstand the reduction in effective leaf area, their vigour is reduced and the plants are consequently set back.

### Family Yponomeutidae

Although lacking a common name, the yponomeutids contain some of the most attractive moths, many of which are white or yellow with dark markings or spots.

One economic species is the cabbage moth (*Plutella maculipennis*) which feeds on crucifers. The larvae feed under the leaves leaving a 'window' of intact cells on the top layer of the leaf. They pupate within a loosely-spun cocoon. The adult moth has a wing span of about 1.2 cm, and is a white moth with black, diamond-shaped markings.

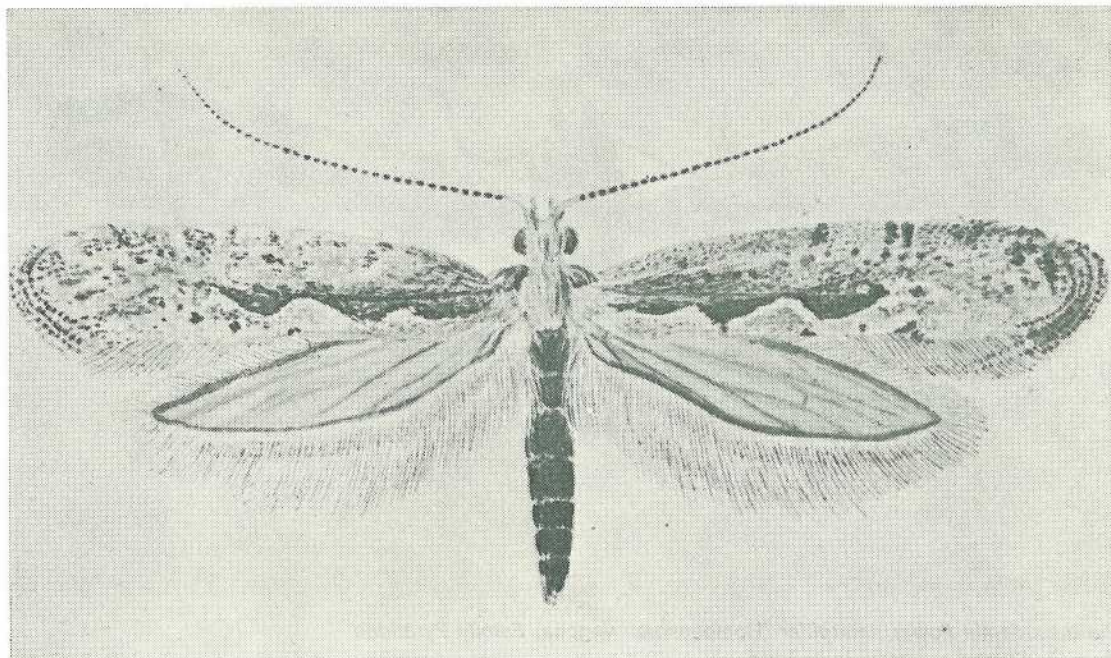

*Cabbage moth (Plutella maculipennis).*

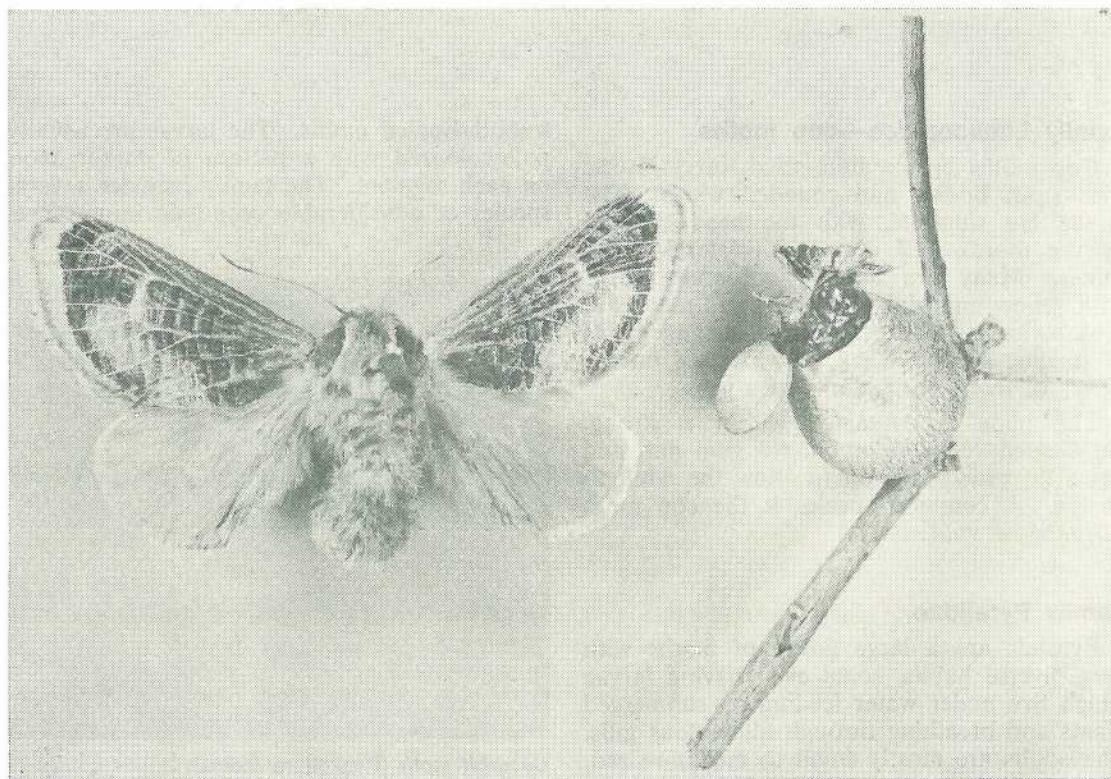

*The cup moth (Doratifera vulnerans) and its pupal case.*

*May-June 1978*

*Queensland Agricultural Journal*

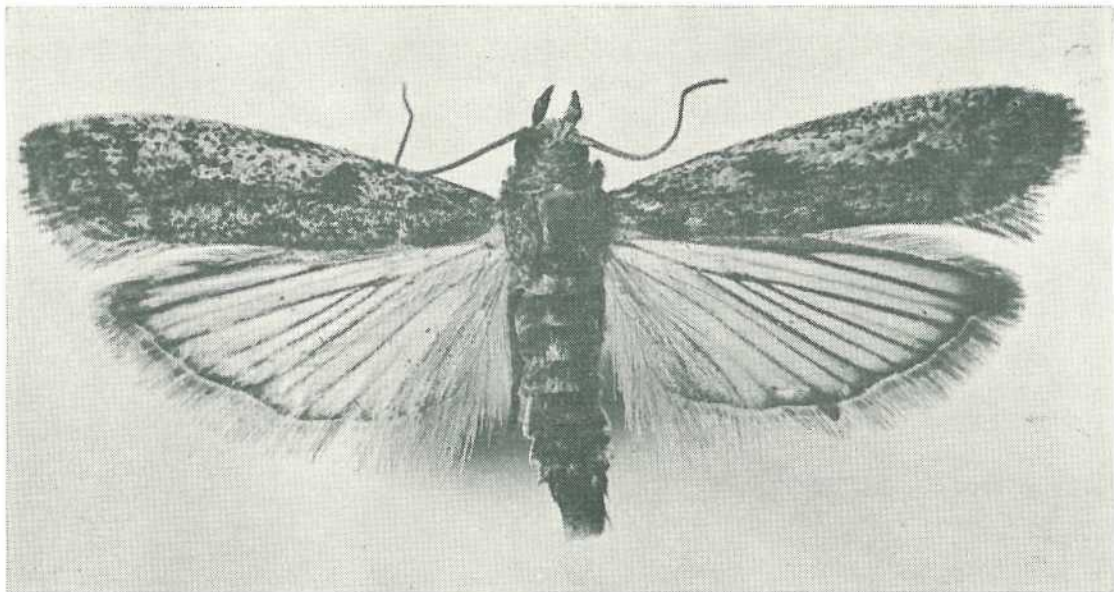

The macadamia flower caterpillar (*Homoeosoma vagella*) Family Pyralidae

#### Family Limacodidae—cup moths

Cup moths are medium-sized, furry insects with stout bodies and rounded wings. The larvae are slug-like, with the head covered by the thorax and often with lateral fleshy spikes. Many are brightly coloured greens with yellow and pink markings, and may have protuberances with flower-like arrangements of stinging spines. They feed exposed on the leaves of trees, particularly eucalypts.

The pupa is contained within a strong, cup-shaped vessel resembling a gum nut, and has a lid which falls off to allow the adult to escape. A common species is the cup moth (*Doratifera vulnerans*).

#### Family Pyralidae

Pyralids are a large group of moths with very diverse habits, some even having larvae which live under water feeding on submerged plants and breathing through filamentous gills. The adults are mostly small to medium-sized,

smooth-bodied moths. The larvae are usually pale-coloured with a pattern of darker spots on each segment. The family includes several species of considerable economic importance.

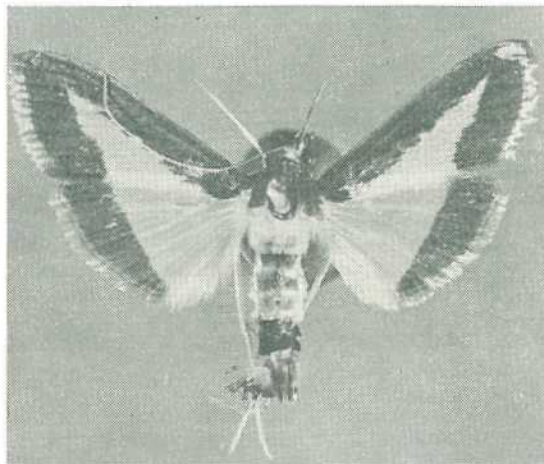

Cucurbit moth (*Phakellura indica*).

Species of *Epipaschia* and *Macalla* make shelters of leaf fragments and frass webbed together on ornamentals such as *Leptospermum* and *Melaleuca*. The larvae leave the shelter at night to feed and gradually defoliate the plant up to some distance from the shelter, where they finally pupate. Other species of these genera feed amongst the leaf litter on the ground.

One of the more common moths in the Brisbane area is the sod webworm (*Herpetogramma licarsialis*) the larvae of which feed on lawns and can cause considerable damage. The adults are a mottled brown moth with a wing span of about 2.5 cm and are attracted to household lights in large numbers during warm weather. The females lay irregular, furry egg masses under eaves, on ceilings, etc., from which the newly hatched larvae lower themselves on a silk thread.

Included in the pyralids are some serious introduced pests of stored grain products including the tropical warehouse moth (*Ephestia cautella*), the indian meal moth (*Plodia interpunctella*) and the rice moth (*Corcyra cephalonica*). These species are cosmopolitan, having been freely transported from country to country last century by the grain clippers. Today, rigid inspections and chemical controls largely prevent this movement although the insects remain a problem on our farms and in our domestic grain stores.

Though rice is a relatively new crop in north Queensland it already has its share of insect pests. Among these is the stem borer (*Tryporyza innotata*), a shining, white moth with the wings extending some 2.5 cm. As its name suggests, the larvae tunnel inside the stem of the rice plant, weakening it so that affected plants often fall over and the grains cannot be harvested.

About the same size is *Phakellura indica*, an attractive moth having white wings with broad, brown margins. The larvae feed on cucurbits while *Maruca testulalis* bores in bean pods. *Sceliodes cordalis* attacks egg fruit. The yellow peach moth (*Dichocrocis punctiferalis*) is a bright yellow moth with black markings on the wings. The larvae feed on a variety of crops including peaches, papaw and sorghum.

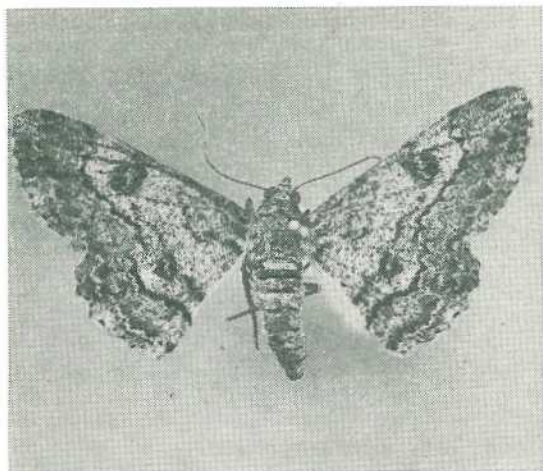

A typical geometrid.

Probably the most famous pyralid is the prickly pear moth (*Cactoblastis cactorum*) which was introduced to Queensland from South America during the 1920s to combat prickly pear which at that time had invaded millions of hectares of grazing country. To its credit, *Cactoblastis* liberated almost all of this land single-handed, and even today maintains the pear at harmless proportions.

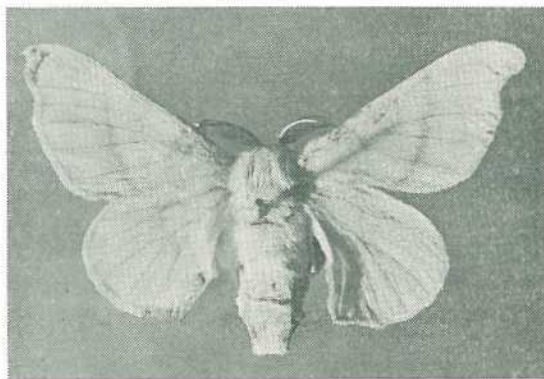

The silk worm (*Bombyx mori*).

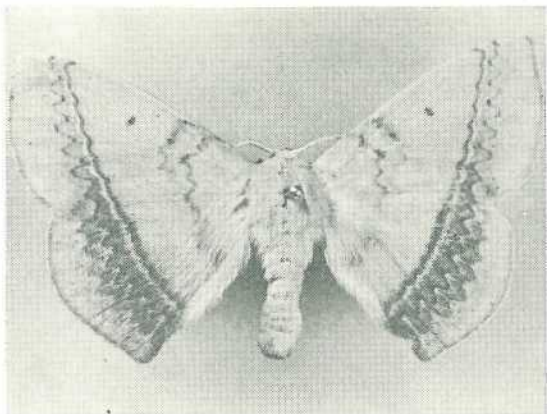

*Anthela varia*, a typical anthelid.

The female moth lays her eggs glued to each other end to end in a long 'egg stick' which is attached to the prickly pear plant. The

larvae chew through the tough outer skin and feed on the flesh and soon reduce the plant to pulp.

Insects, it seems, have no respect for anyone, not even other insects. The wax moths (*Galleria mellonella* and *Achroia grisella*) live inside the hives of honey bees where they feed on old wax and debris left by the bees and can cause considerable damage to frames and foundations. However, the presence of wax moth in a hive is usually an indication of a weak condition which should be remedied. In strong hives, the guard bees at the entrance are able to repel moths trying to enter.

Some native species live in dense rain-forest where the larvae feed on mosses, others are associated with rushes and sedges in swamps, while a few live under loose bark on eucalypts. The old saying that 'where there's a will, there's a way' can really be applied to the pyralids, for they have colonized almost every conceivable habitat, and made a success of it.

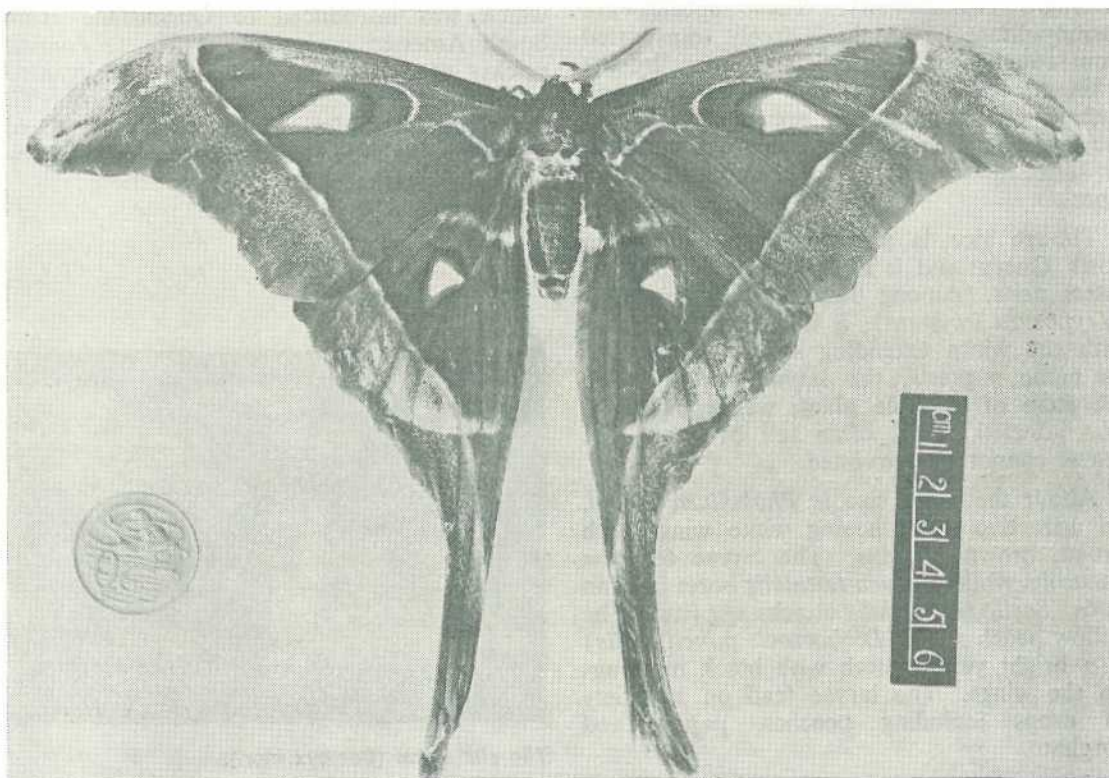

*Atlas moth* (*Coscinocera hercules*).

### Family Geometridae—loopers

Loopers are so-called because of the characteristic movements of the larvae. These have the abdominal prolegs reduced to one or two hind-most pairs, and move in a series of loops by extending the head and thorax as far forward as possible and then drawing up the tip of the abdomen. This has the effect of arching the body upwards, and the larva moves by a succession of loops, hence their common name.

When disturbed on a branch, the larvae straighten their body and hang suspended by the posterior prolegs. In this stance they may remain motionless for long periods looking for all the world like a twig, and thus escape detection.

The adults are slender moths with large, delicate wings (often with scalloped margins) and rest with the wings spread out like a fan against the substrate. Many have wing patterns of light and dark wavy lines and are well camouflaged when resting on bark. Others have bright green wings and are very attractive.

The larvae feed widely on native eucalypts, acacias, banksias etc. but few are of economic importance.

### Family Bombycidae—silk worms

No discussion about moths could be complete without mention of the silk worm (*Bombyx mori*). A native of China, it was domesticated centuries ago for the fine silk of the cocoon made by the larvae before pupation. The silk strand is fine but strong, and can be recovered from the cocoon by careful unwinding. The Chinese also discovered that by varying the food plant of the larvae, the colour of the silk could be altered.

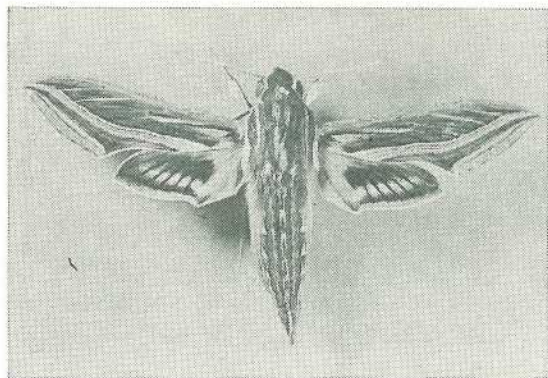

A hawk moth (*Hippotion celerio*).

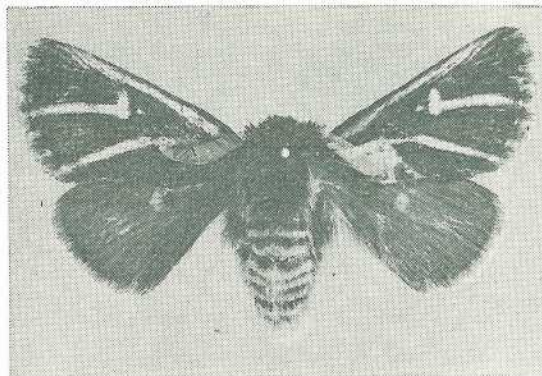

Processional caterpillar (*Ochrogaster contraria*).

The silk worm was introduced into Australia where for generations it has been the first study of an insect life cycle for many school children.

### Family Anthelidae

Anthelids are large moths with stout, furry bodies and broad wings often patterned with stripes. However, some species such as *Anthela varia* are very variable in colour and pattern. This misled earlier students of the group who considered the different forms to be separate species. In most species, the antennae of the males are prominent and feathery. Australia is the home of the anthelids. With the exception of neighbouring New Guinea, anthelids are to be found nowhere else in the world. The larvae are generally very hairy, and some bear stinging hairs.

### Family Saturniidae—emperor moths

The emperor moths are related to the anthelids but can be distinguished by the large eye spots on the wings. The emperor gum moth (*Antheraea eucalypti*) has a large, blue-green caterpillar and feeds on eucalypts. The pupal period may last several years and the cocoon is very hard and ornamented with pieces of bark. When the adult emerges, it regurgitates a fluid which softens the cocoon, allowing it to escape.

One of the world's largest moths is the Australian atlas moth (*Coscinocera hercules*) which is found in the rain-forests of north Queensland. It commonly attains a wing span of 25 cm. The male has a long-tailed hindwing while that of the female is rounded.

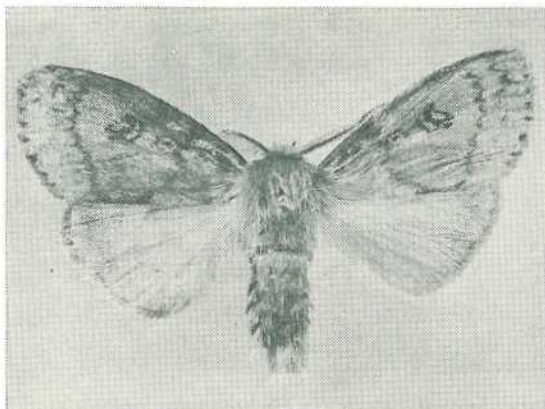

White cedar moth (*Leptocneria reducta*).

### Family Sphingidae—hawk moths

The hawk moths are large, fast-flying species with smooth, cigar-shaped bodies. The hindwing is much smaller than the forewing and the antennae often have a terminal hook.

The larvae are thick, smooth-skinned caterpillars marked with brilliant eye spots and stripes of various striking colours. They are characterized by a curved, fleshy spine on the last segment. When they are ready to pupate, the larvae bury themselves in the soil beneath the host plant.

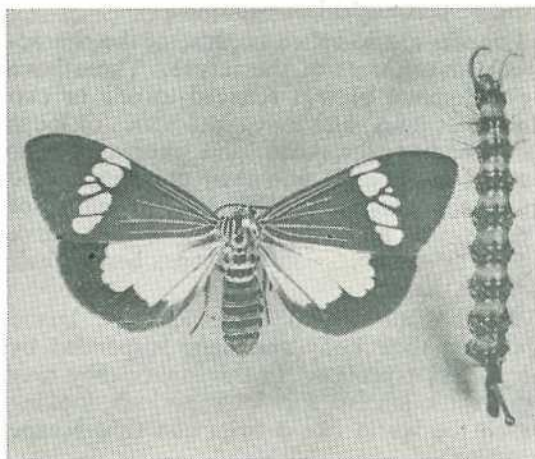

An arctiid (*Nyctemera* sp.) and its larva.

The adults are mostly active at dusk but the bright green *Cephnodes kingi* flies during sunshine. Its wings are largely scaleless and the moth resembles a large bumble bee as it darts from flower to flower seeking nectar.

Other common species include *Theretra oldenlandiae* and *Hippotion celerio* which feed on vines. In western Queensland, *Coenotes eremophilae* feeds on turkey bush which it occasionally defoliates.

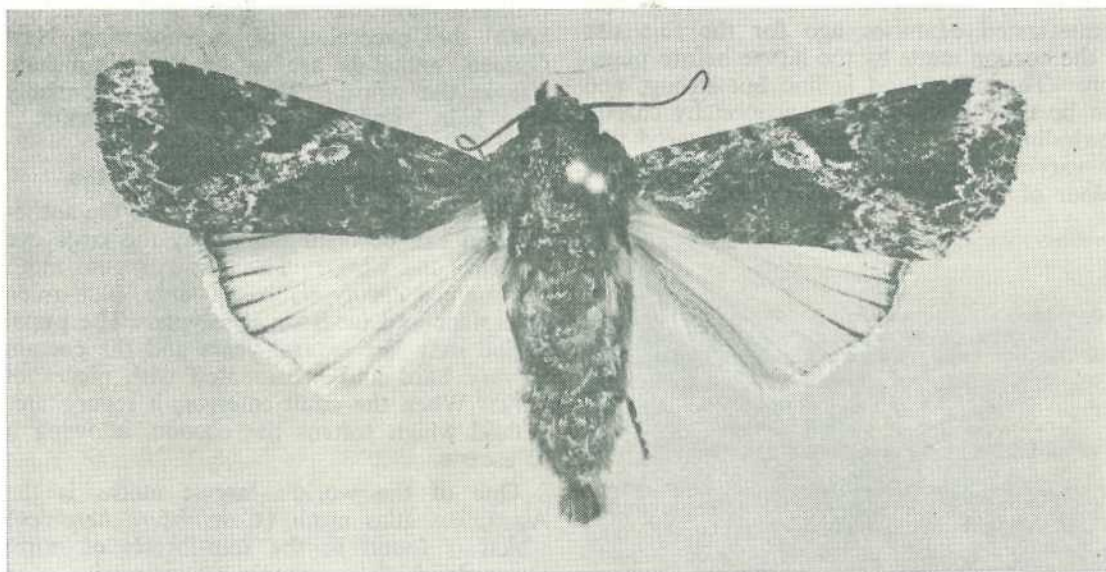

Lawn armyworm (*Spodoptera mauritia*).



### Family Notodontidae—bag moths

Probably the best known member of this group is the processional caterpillar (*Ochrogaster contraria*). The larvae are covered in a dense mat of long, stinging hairs and live in communal shelters formed by webbing together the leaves of the host plant. The larvae congregate within the 'bag' during the day and it gradually fills up with frass and cast skins. The bag often remains in the tree long after the larvae have departed.

At night, the larvae move out to feed—the colony keeping together by travelling nose to tail in a long procession. If a tree is defoliated, they will crawl away to find another. During these migrations they are often encountered by young children, who soon learn to treat them with respect after receiving a dose of their stinging hairs. The affected area usually comes out in an irritating rash for a day or so but there are no lasting effects.

The adults are very hairy, large moths with a wing span of some 4 to 6 cm. The

wings are brown with white markings and the abdomen is banded in orange and black.

The favoured host plants are wattles and eucalypts.

### Family Lymantriidae—tussock moths

These are medium to large moths with broad wings and very hairy bodies. Neither sex feeds and some females are even wingless. The larvae are also very hairy, and some have long tufts of hair on the dorsal surface which gives rise to their common name. In many species, the hairs are urticating and can produce a severe sting and rash if handled.

One such species is the white cedar moth (*Leptocneria reducta*) which regularly defoliates white cedar trees in Queensland.

### Family Arctiidae—tiger moths

Arctiids are small to medium-sized, brightly coloured moths often yellow or red with darker markings. The larvae are very hairy and some possess urticating hairs.

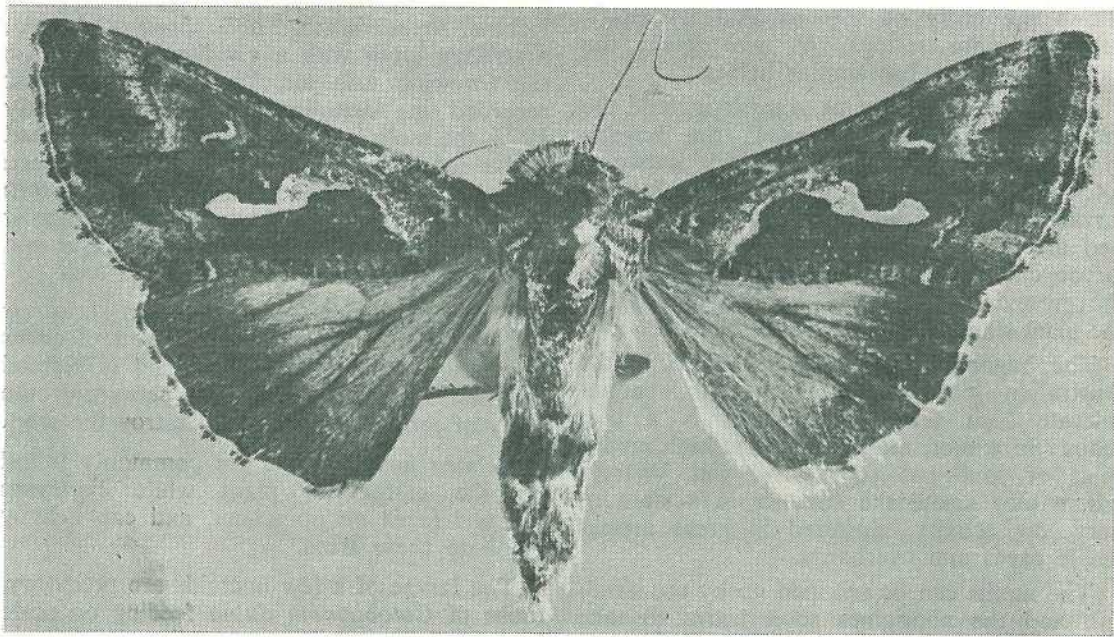

Tobacco looper (*Plusia argentifera*).

Resembling small butterflies are the black and white day-active species of the genus *Nyctemera*.

### Family Noctuidae—cutworms, armyworms, etc.

The noctuids are one of the largest groups of moths and certainly the most economically damaging including well known genera like *Heliothis*, *Agrotis*, *Pseudaletia* and *Plusia*.

Noctuids vary greatly in appearance, but many are medium to large moths with patterned forewings and pale hind wings, and a stout body. Some are brightly coloured, but greys and browns predominate.

Mostly, the adults hide during the day in crevices, under bark etc. and feed at night on nectar or fermenting fruit. The larvae are usually smooth-skinned, only sparsely haired and have a pattern of longitudinal stripes. Some have reduced prolegs like loopers. Most pupate in the soil.

The world-wide genus *Heliothis* has four species in Australia, two of which are particularly harmful. *H. armigera*, the corn ear worm, attacks cotton, sorghum, linseed, maize etc. and has a particular preference for the developing seeds. The hole made by the larva allows the entry of rots so that its attack becomes more serious. *H. punctigera*, the native budworm, has similar habits.

Cutworms of the genus *Agrotis* include the brown cutworm (*A. munda*), the bogong moth (*A. infusa*) and the black cutworm (*A. ypsilon*). Cutworms are night-feeding larvae, hiding by day in debris or in the soil and are a pest mainly of young crops. The larvae chew through the plant stem close to the ground and feed on the leaves, so that the plant stand may be severely thinned.

The bogong moth was well known to the Australian aborigines. The moth cannot tolerate high temperatures, and is a pest mainly in winter, migrating to the high mountains of south-eastern N.S.W. and Victoria where they spend the summer in a state of very low activity, clustered in great masses inside caves and overhangs.

The moths can be scooped up by the hand-ful, and the aborigines soon learnt to take advantage of this habit. They would lightly singe the moths to remove legs and wings and

then grind the bodies into a damper-like paste and cook them. The bodies are rich in stored fats and proteins to allow the moths to survive many months without feeding, and doubtless represented a valuable food source to the natives, rather like the bunya nut feasts in Queensland.

Armyworm pests include *Pseudaletia convecta*, *P. separata* and *Persectania ewingii* which attack grasses and cereals. Their common name comes from the fact that when present in very large numbers, the larvae may move through a crop along a front, rather like an advancing army.

The cluster caterpillar (*Spodoptera litura*) is a pest of many vegetable crops, and also strawberries, tobacco and maize. *S. mauritia*, however, is a pest of pastures including garden lawns, the larvae feeding on foliage at night. *S. exempta* is a serious pest of tobacco in north Queensland.

The rough bollworm (*Earias heugli*) attacks maturing cotton bolls. As well as damaging the fibres making them too short to use, the entry hole also allows the penetration of rotting organisms in wet weather.

The loopers (*Plusia argentifera* and *P. chalcites*) are leaf feeders on crops such as lucerne, soybeans etc. *Trichoplusia orichalea*, a striking moth with a vivid golden flash on the forewing also attacks such crops. First recorded in Australia at Mareeba in early 1975, the moth has now known to have spread as far south as Sydney and has recently been recorded at Emerald in central western Queensland. The moth has caused economic losses to soybeans in the Burnett, Lockyer and Darling Downs areas in recent seasons.

The large fruit sucking moths (*Othreis materna* and *O. fullonia*) are a pest of citrus and other tropical fruit. The rind is pierced by their sharp haustellum so permitting the entry of moulds which soon destroy the fruit.

*Achaea janata* larvae are commonly found on the castor oil plant while *Pericyma cruegeri* feeds on poinciana, and can heavily defoliate these trees.

The larvae of a few noctuids are predatory, those of *Catoblemma dubia* feeding on scale insects, using the dead bodies in cocoon construction.

### Family Agaristidae—day moths

The agaristids are another group of day-flying moths. They are mostly dark-coloured, but are relieved by patches of red, yellow and blue. The larvae of *Agarista agricola* feed on vines.

The whistling moths (*Hecatesia* spp.) are particularly interesting. The males, which fly at dusk, have a raised knob on the forewing margin and portion of the wing behind it without scales and raised into a series of ridges. These knobs hit each other as the wings meet over the body during flight causing the ribbed area to vibrate, producing a low whistle. The

purpose of this sound-producing mechanism is not known.

The Lepidoptera probably owe their success partly to their exploitation of plants as feeding sites: roots, trunks, branches, twigs, leaves, bark, flowers, fruits and fallen leaves and fruit are all utilized. But their success has been their downfall too, for their predilection for plants has brought many of them into conflict with man and the battle wages constantly. The insects have the numbers but man has his chemicals. Who will win?

For more information on moths, see the back cover of this issue.

---

## Bovine brucellosis protected area expanded

The Minister for Primary Industries, Mr V. B. Sullivan, announced a substantial expansion of the Bovine brucellosis protected area in Queensland.

'It has been made possible due to the excellent co-operation received from all sections of the cattle industry, despite the present difficulties facing both graziers and dairy farmers,' he said.

'As from May 1, a further 51 shires and three cities were included in an expansion of the existing protected areas, which now extend from the New South Wales border to Cape York.'

Eradication of brucellosis-infected cattle within such shires and cities would be compulsory from that date. Compensation would apply.

Compulsory controls also would be placed on the movement of cattle into, and within the expanded protected area. However, they would be phased in over a period of 3 months to enable producers to adapt to them and to obviate, as much as possible, any disruption of movements to normal outlets.

At the same time, opportunity is being taken to amend the conditions of entry to the bovine tuberculosis protected area and to introduce movement controls within this area.

Information concerning movement conditions relating to the brucellosis and tuberculosis areas could be obtained from local Stock Inspectors or Divisional Veterinary Officers.

# The perennial fruits

A bountiful harvest of dried fruits, lies waiting on the health food store and supermarket shelves.

You will probably be surprised by the array before you—pears, peaches, apple rings, bananas or figs—all dried and bursting with the concentrated flavour of the original fruit.

Even the ancient Egyptians were not slow to realize the preserving qualities which drying gave, for they utilized the heat of the sun to provide a year-round supply of their favourite fruits.

Though the raisins in the cupboard may seem a common fruit to you, their ancient relatives were far from humble—the Persians even considered the raisin with such esteem that it was once considered as legal tender.

But that is the past. To-day, the distinct tang of dried fruits can be incorporated into endless dishes—and here are just a few ideas on how they can be used.

*Recipes provided by the Dairy Foods Advisory Bureau.*



*Golden fudge ring.*

## **Golden fudge ring**

Standard 250 ml measuring cup and 20 ml tablespoon are used. All measurements are level.

- 1 x 127 g can passionfruit pulp
- $\frac{1}{4}$  cup raisins
- 1 x 125 g packet Australian cream cheese
- 2 tablespoons butter
- $\frac{3}{4}$  cup sugar
- 3 eggs
- 1 cup self raising flour
- grated rind of one orange
- $\frac{1}{4}$  cup orange juice

Combine passionfruit pulp and raisins. Spread evenly over the base of a buttered 20 cm ring cake pan. Cream together cream cheese, butter and sugar. Beat in eggs one at a time. Sift flour over the mixture. Fold in thoroughly. Add orange rind and juice and combine well. Spoon mixture over passionfruit pulp in cake pan. Bake at 180° for 40 to 45 minutes. Turn out cake immediately onto a serving plate. Serve with whipped cream. Serves 6 to 8.

### Orange buttered schnitzels

- 4 x 60-90 g veal steaks, cut from the leg
- $\frac{1}{4}$  teaspoon salt
- $\frac{1}{4}$  teaspoon ground cloves
- 4 x 30 g slices Australian matured cheddar cheese
- 1 small orange, peeled and cut into 5 mm slices
- 8 prunes, stoned
- 2 tablespoons seasoned flour
- 2 tablespoons butter

Batten out veal steaks to about 5 mm thickness between 2 sheets of plastic wrap. Sprinkle lightly with ground cloves and salt. Place a slice of cheese and orange on half of steak. Top each with two prunes. Fold meat in half, covering filling. Toothpick securely together. Toss lightly in seasoned flour. Melt butter in a heavy based pan. Fry veal till cooked and browned on both sides, approximately 15 to 20 minutes. Top with savoury orange butter (see below). Serve with a crisp tossed vegetable salad. Serves 4.



### Savoury orange butter

- 3 tablespoons butter, softened to room temperature
- 1 tablespoon finely grated orange rind

Cream together butter and orange rind. Roll mixture into a sausage shape 2 cm in diameter. Wrap in greaseproof paper. Refrigerate till firm. Cut into 5 mm slices.

### Applecake slice

- 1 cup chopped dried apples
  - $\frac{1}{2}$  cup chopped dates
  - $\frac{3}{4}$  cup sweet non-alcoholic apple cider
- Mix the above ingredients together. Leave covered for at least 2 hours.

#### THE BASE

- 1 cup plain flour
- $\frac{1}{2}$  teaspoon baking powder
- $\frac{1}{2}$  cup sugar
- 3 tablespoons butter
- 1 egg
- $\frac{1}{4}$  cup milk

Sift flour and baking powder together in a large bowl. Add sugar. Rub in butter till mixture resembles fine breadcrumbs. Beat together egg and milk. Stir into flour mixture. Spoon into the base of a buttered 23 cm square cake pan. Drain fruit and reserve the liquid. Scatter fruit over the cake mixture. Spoon over the topping (see below). Bake at 190°C for 20 minutes. Reduce heat to 180°C. Bake a further 30 minutes or till cooked when tested with a skewer.

#### THE TOPPING

- 1 $\frac{1}{4}$  cups Australian Ricotta cheese
- $\frac{1}{4}$  cup sugar
- 2 eggs, separated
- 2 tablespoons plain flour
- reserved juice from fruit
- 1 tablespoon sugar

Blend cheese, sugar, egg yolks, flour and reserved fruit juice together in a large bowl. Beat egg whites adding sugar to make a firm meringue. Fold into cheese mixture. Serves 6 to 8.



**Subscribe now**

# 'The Queensland Agricultural Journal'

## Concession rate available

Persons eligible for concession rate include commercial farmers whose principal source of income is from primary production, students of agricultural courses, libraries and educational institutions (all resident in Queensland). Students' applications should be endorsed by the lecturer or teacher.

---

---

### QUEENSLAND AGRICULTURAL JOURNAL ORDER FORM

#### Subscription Rates—

Ordinary — \$6.90 per annum (Australian Currency)

Concession rate — \$2.30 per annum

NAME <sup>Mr</sup>.....  
<sup>Mrs</sup>.....  
<sup>Miss</sup>..... (SURNAME IN BLOCK LETTERS) (INITIALS)

PRESENT ADDRESS..... POSTCODE.....

PREVIOUS ADDRESS (if applicable).....

OCCUPATION.....

I hereby enclose \$ ..... for ..... years subscription (2 year limit).

New Subscriber

Renewal

(Tick the one that applies)

Signature.....

Office Use Only

# Identifying insects—moths

COMPARED to butterflies, moths are usually regarded as being the 'ugly sisters' of the Lepidoptera order.

Yet, moths are often very attractive insects as these photographs show.

**Plate 1.** A swift moth (*Aenetus* sp.). This genus contains many beautiful moths which are often sexually dimorphic. In this case, the female is shown; the male lacks the pinkish areas and is totally green.

As their name suggests, these moths are strong fliers, and many are attracted to lights. The larvae form tunnels in living trees, making a resting tunnel, and emerge at night to feed on bark. They cover the entrance to the tunnel with a curtain of frass and wood particles woven together by silk.

**Plate 2.** The yellow peach moth (*Dichocrocis punctiferalis*) family Pyralidae, is a pest of a wide range of crops including cotton, sorghum, maize, macadamia nuts, beans and stone fruit. The adult moth is easily recognized by its pattern of dark markings and the underlying yellow colour. The larvae reach about 2.5 cm in length and are pale-coloured with a dark head and dark spots on each body segment.

The Pyralids are one of the larger families of moths and exhibit a wide range of shape, colour and habits, although most are sombre moths, unlike the yellow peach moth.

**Plate 3.** The emperor gum moth (*Antheraea eucalypti*) is a large moth with a wing span of some 10 or 12 cm. They have large, bright eyespots on the wings and rest with the hindwings partly covered by the forewings. If disturbed, they often depress the head, curl up the abdomen, and give the forewings a quick flick, exposing the eyespots on the hindwings. These actions may startle a would-be predator and allow the moth to survive.

The larvae are a bright bluish-green and feed on eucalypts and attach their hard, oval cocoons to the bark of the tree.

**Plate 4.** The bee hawk (*Cephnodes kingi*) is a rather unusual member of the family Sphingidae since it is active by day—most hawk moths do not become active until dusk. The hawk moths are named because their bodies are streamlined and they fly rapidly. They are nectar feeders, but seldom alight, and usually hover near a flower while they suck up its load of nectar, before darting off to the next.

It should also be noticed that *C. kingi* has transparent wings. The scales are very loosely attached and most fall off during the first few flights made by the moth. Being brightly marked, the moth resembles a large bee as it flies about in the sunshine.

**Plate 5.** The fruit-sucking moth (*Othreis fullonia*) is one of the few moths which are pests as adults. In most cases, the damage is attributable to the feeding of the larva. Fruit-sucking moths are able to pierce the rind of citrus and other tropical fruit to suck up their juices. In damp weather, moulds may enter the fruit through the feeding puncture and soon destroy it.

**Plate 6.** The vine moth (*Agarista agricola*) is so brightly patterned that one could be forgiving for thinking it was a butterfly, especially as they also fly by day. The larvae are boldly striped in black and white, and feed on vines. The moth belongs to the family Agaristidae, and most have black and orange markings and fly by day. They are probably distasteful to birds and other predators so they are able to fly without fear.

---

by B. K. CANTRELL,  
Entomology Branch.

# Identifying insects—moths



Plate 1. Swift moth (*Aenetus* sp.).



Plate 2. Yellow peach moth (*Dichocrocis punctiferalis*).



Plate 3. Emperor gum moth (*Antheraea eucalypti*).



Plate 4. Bee hawk (*Cepnodes kingi*).



Plate 5. Fruit-sucking moth (*Othreis fullonia*).

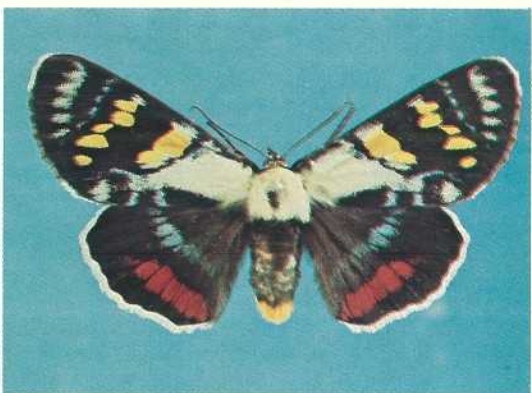

Plate 6. Vine moth (*Agarista agricola*).