

CSIRO Publishing

# Australian Journal of Experimental Agriculture

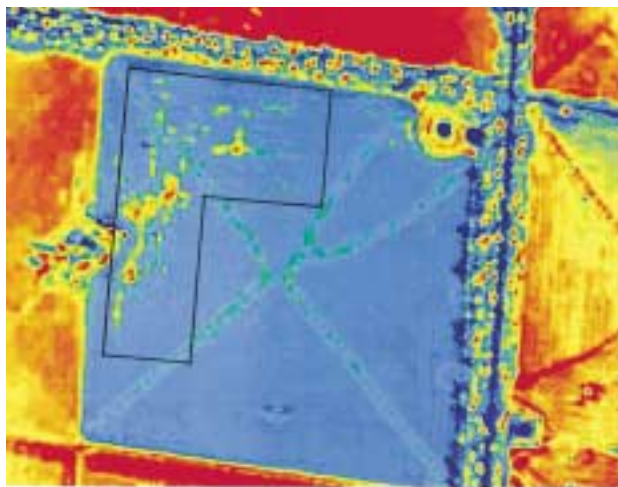

VOLUME 42, 2002

© CSIRO 2002

*... a journal publishing papers at the cutting edge  
of applied agricultural research*

**All enquiries and manuscripts should be directed to:**

*Australian Journal of Experimental Agriculture*  
CSIRO Publishing  
PO Box 1139 (150 Oxford Street)  
Collingwood, Vic. 3066, Australia



**CSIRO**  
PUBLISHING

Telephone: +61 3 9662 7614  
Fax: +61 3 9662 7611  
Email: [publishing.ajea@csiro.au](mailto:publishing.ajea@csiro.au)

Published by CSIRO Publishing  
for the **Standing Committee on  
Agriculture and Resource Management (SCARM)**

[www.publish.csiro.au/journals/ajea](http://www.publish.csiro.au/journals/ajea)

## An accurate and mobile weigh bin for peanuts

S. Krosch<sup>A</sup>, G. C. Wright<sup>A,C</sup>, S. Ashcroft<sup>B</sup> and P. Shanahan<sup>B</sup>

<sup>A</sup>Queensland Department of Primary Industries, Kingaroy, Qld 4610, Australia.

<sup>B</sup>A & S Engineering Services, Kingaroy, Qld 4610, Australia.

<sup>C</sup>Author for correspondence; e-mail: Wrightg@dpi.qld.gov.au

**Abstract.** The design of a mobile weigh bin for use in field trials is described. The bin is designed for accurate weighing of peanut yield (pods) from large-scale (1 t) on-farm trials. It can be used with most commercially available peanut threshers and unloads pods quickly into transport trucks, resulting in minimal delay to a farmer's harvesting program.

### Introduction

Yield assessment of peanut plots usually involves the cutting, threshing and bagging of samples in the field, followed by pre-cleaning and weighing in a protected and often off-site location. This procedure works well when working with small plots; however, this approach is of limited use when working in larger field plots (e.g. greater than 0.1 ha). With the recent trend to conduct larger scale on-farm trials using farmer cooperators (Robertson *et al.* 2000), there is a need to design a better system of weighing large peanut trial plots.

A number of mobile weighing bin designs have been developed for crops such as maize, sorghum, wheat and some forages (e.g. Pearson and Robinson 1994). Most of these designs use a large field bin (up to 1-t capacity) mounted on electronic load cells for weight measurement, and a screw auger for transfer of grain into a truck and/or trailer. Previous mobile weighing bin designs are not, however, directly applicable for peanuts because the action of the screw auger would cause considerable damage to fragile peanut pods. A practical system for unloading peanuts from the weighing bin without damaging pods was therefore required.

In this paper, we describe a practical mobile weigh-bin design for use in large-scale peanut yield trials in which samples of up to 1.2 t of peanut pods can be weighed to an accuracy of 1 kg.

### Construction and operation

A number of important features were needed for an acceptable mobile peanut weigh bin design. A bin with a large capacity for peanuts (about 4 m<sup>3</sup>) fitted onto a simple and accurate weighing system, along with a suitable unloading method, was required. A few options were available to lift peanuts from the bin. The first was a conventional belt elevator. This was ruled out because the length of the belt required to obtain the correct slope to unload pods meant the belt had to be folded a number of

times to be transported. The second option considered was an air-driven 'tubevator'. We were unable to pursue this system, as there was lack of information regarding its operation and cost. The third method was a new and innovative one, involving a steep-angled cleated conveyor. All these features needed to be mounted on a trailer for easy transport and for use at multiple locations.

The weigh bin consists of a holding bin located above a steep-angled, cleated-belt elevator used for unloading (Fig. 1, A). The bin sits on 3 load cells (Ruddweigh Millimix 15 kit) that are attached to a 12 V digital readout (Ruddweigh KM3) fitted to the side of the trailer (Fig. 1, B). The load cells have a capacity of 15 t, with a resolution of  $\pm 1$  kg. The bin was constructed from sheet metal (2 mm), with dimensions 2670 mm long, 1600 mm high, 1880 mm wide at the top and 300 mm wide at the bottom, giving a volume of about 4 m<sup>3</sup>. The bin can hold nearly 1.2 t of pods when fully loaded, and is therefore large enough to receive a typical load from most commercial threshers used in Australia and overseas. The sides of the 'V'-bottom bin are built at a slope of 40 degrees



**Figure 1.** Side view of the weigh bin, showing the holding bin (A), digital readout (B), sample chute (C) and elevator system capable of transferring peanut to a height of 4 m (D).



**Figure 2.** Front view of the weigh bin, showing the ‘V’-bottom bin (A), wind-out sliding door (B), elevator belt folded in transport position (C).

so the peanuts will readily fall to the unloading point at the base of the bin (Fig. 2, A). Unloading of pods can be controlled using a windout sliding door (Fig. 2, B). A 150-mm-diameter chute is also located on the side of the bin so that a subsample can easily be obtained from the load (Fig. 1, C).

The weigh bin is located neatly above a steep-angle conveyor that consists of cleats bonded to a reinforced fabric belt with flexible corrugated sidewalls. This ensures that the belt has flexibility to convey peanuts at any angle between 0 and 90 degrees from the horizontal.

The belt elevator is able to lift peanuts from the bin to a height of 4 m (Fig. 1, D). The elevator is driven by a 5 HP Kawasaki petrol motor fitted with an over-centre clutch mechanism which is used to engage and disengage the belt. A typical 1 t load can be transferred in less than 5 min. This means that weighing peanut samples can be done quickly without undue delay for cooperating farmers. This system is very desirable because researchers do not rely on the use of farmers’ transfer equipment (e.g. elevators), thus making the weighing job simple and rapid.

The elevator can be folded back over the bin during transport (Fig. 2, C), and raised and lowered by a hand-winch fitted to the side of the trailer. The flexibility of the cleated-belt elevating mechanism is ideal for this purpose, as

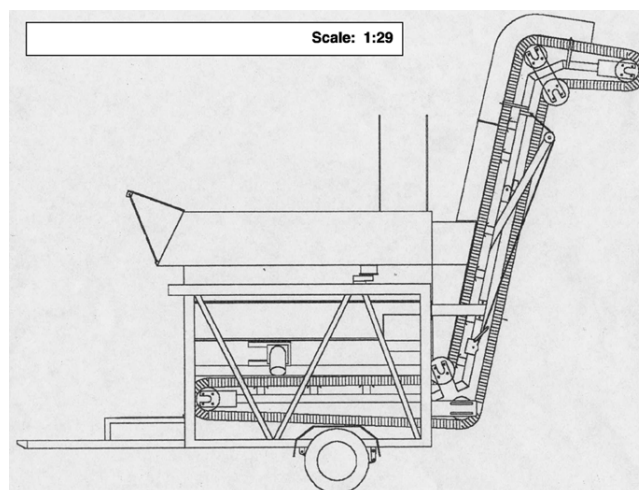

**Figure 3.** Scaled drawing of weigh bin.

the belt can be folded at very steep angles (up to 90 degrees). A scaled drawing of the mobile weigh bin design is presented in Figure 3.

The trailer is constructed from rectangular hollow section steel and fitted with suitable load-rating tyres, rims, hubs, axles, and electric brakes for highway use. It is also fitted with 2 front- and 2 rear-support legs, which can be extended for load bearing when in the field. The weigh bin has a tare weight of 1.3 t and can be easily towed behind most light vehicles.

### Field testing

The weigh bin was initially tested under a range of conditions to determine general performance and accuracy of measurement. An experiment was conducted where a range of known weights (i.e. bags of fertiliser) from 50 to 900 kg were loaded sequentially onto the weigh bin under 3 operating conditions, viz. bitumen, grass and a cultivated paddock (Table 1). The loading of weights and associated weighing procedure were identical under the 3 operating conditions, with load-cell recordings made at intervals of about 50, 250, 600 and 900 kg. Recordings under each operating condition were replicated 3 times, using a fork lift to transfer the fertiliser-bag test weights on and off the weigh bin. The accuracy of the load cell was checked against

**Table 1.** Weigh bin weight recordings from various test weights performed under three surfaces (bitumen, grass and cultivation)

Measurements are the mean of three replicate readings, with standard errors in the parentheses

	Test weight (kg)		
	Bitumen	Grass	Cultivation
Weighing platform	52.0 ± 0	52.0 ± 0	52.7 ± 0.58
Platform + 5 bags of fertiliser	263.0 ± 0	263.0 ± 0	263.0 ± 0
Platform + 14 bags of fertiliser	618.0 ± 0	618.0 ± 0	617.0 ± 0
Platform + 21 bags of fertiliser	898.0 ± 0	898.0 ± 0	898.0 ± 0

standard weights of water and found to be accurate within  $\pm 1$  kg.

Results of this experiment indicated that the weigh bin was extremely accurate, with test weights giving highly repeatable readings (within 1 kg) under the 3 different operating conditions. Preliminary tests conducted before the main experiment had shown that it was vital to ensure the weigh bin was properly levelled using a spirit level. Significant weight variation was observed if the unit was not properly centred and levelled before the measurements were taken.

#### **Acknowledgments**

We thank the Queensland Department of Primary Industries Agency for Food and Fibre Sciences and the

Grains Research and Development Corporation (GRDC) for financial assistance in developing this equipment within projects DAQ 354 and DAQ 468.

#### **References**

- Pearson CH, Robinson L (1994) Automating a commercial swather for harvesting forage plots. *American Society of Agronomy* **86**, 1131–1133.
- Robertson MJ, Carberry PS, Lucy M (2000) Evaluation of a new cropping option using a participatory approach with on-farm monitoring and simulation: a case study of spring-sown mungbeans. *Australian Journal for Agricultural Research* **52**, 1–12.

Received 18 October 2000, accepted 5 September 2001